

Powr-Flite®

PARTS LIST

WET/DRY VACUUMS PF53, PF55, PF57



**WARNING: OPERATOR MUST READ AND UNDERSTAND THIS MANUAL
COMPLETELY BEFORE OPERATING THIS EQUIPMENT.**

Technical Specifications

MODEL	PF53	PF55	PF57
Tank	18 Gauge Stainless Steel	18 Gauge Stainless Steel	18 Gauge Stainless Steel
Motor	1200 Watts	1200 Watts	Dual 1200 Watts
CFM	114	114	192
Waterlift	100"	100"	80"
Tank Size	15	20	20
Power Cord	Pigtail with 30'	Pigtail with 30'	Pigtail with 30'
Primary Filter	Paper Pleated	Paper Pleated	Paper Pleated
Secondary Filter	Washable Cloth	Washable Cloth	Washable Cloth
Drain	Tip and Pour	Tip and Pour	Tip and Pour
Dolly	Heavy-Duty Ployethylene	Heavy-Duty Ployethylene	Heavy-Duty Ployethylene
Wheels	2-" Non-Scuff Rear, 2-3" swivel caster Front	2-" Non-Scuff Rear, 2-3" swivel caster Front	2-" Non-Scuff Rear, 2-3" swivel caster Front
Hose	1.5" x 10' With Swivel Connector/Cuff Lock	1.5" x 10' With Swivel Connector/Cuff Lock	1.5" x 10' With Swivel Connector/Cuff Lock
Tools	14" Rug, Dust, Crevice, and Squeegee	14" Rug, Dust, Crevice, and Squeegee	14" Rug, Dust, Crevice, and Squeegee
Weight	61 lbs.	72 lbs.	78 lbs.

PF53 SCHEMATICS - PARTS LISTS

Head Assesbly

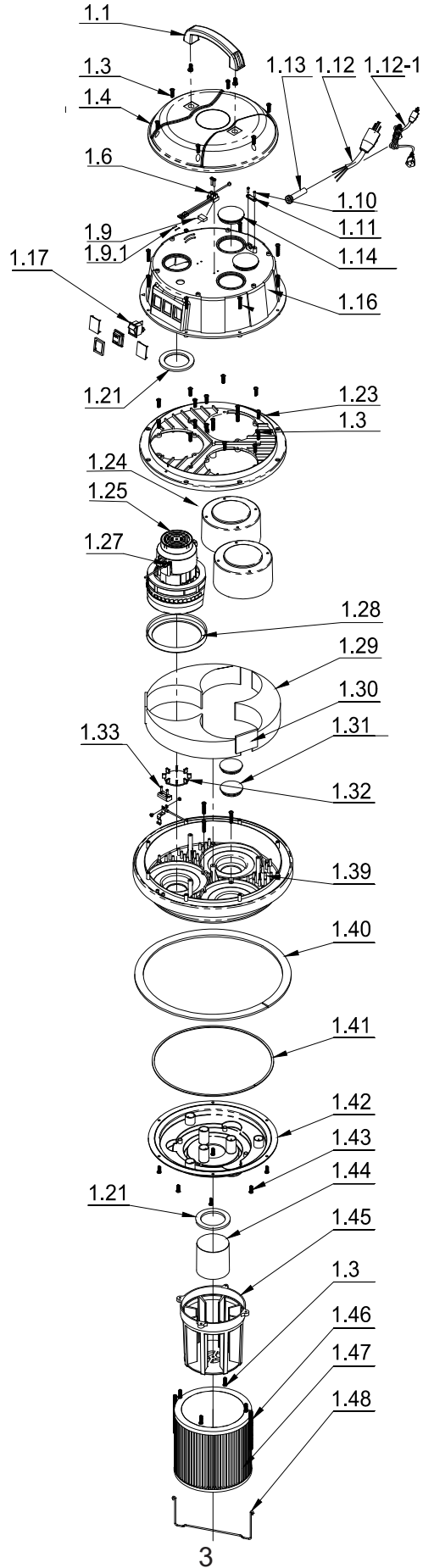

PF53 SCHEMATICS - PARTS LISTS

Head Assesmbly

No.	Part No.	Qty	Description
1.1	WD20A	1	Handle
1.3	3238DS-08	25	Screw M5 x 20
1.4	WD65	1	Top Cover
1.6	WD207	1	Terminal Block
1.9	3215BE-01	1	Capacitor
1.9.1	KK-01	2	Sleeve
1.10	3208DS-07	2	Screw M3.5 x 12
1.11	WD17	1	Wire Plate
1.12	WD66C	1	Pig Tail
1.12.1	WD66	1	Extension Cord
1.13	WD34	1	Strain Relief
1.14	WD83	2	Top Block
1.16	WD16	1	Middle Seat
1.17	WD67	1	Switch Assembly
1.21	WD53	2	Gasket
1.23	WD143	1	Motor Seat
1.24	WD248	2	Bottom Block
1.25	WD15	1	Vacuum Motor
1.27	WD15CB	2	WD15 Carbon Brush
1.28	WD68	1	Gasket
1.29	WD70	3	Foam Gasket
1.30	WD69	1	Square Foam Gasket
1.31	WD82	2	Lower Base Block
1.32	WD85	1	Stopper Plate
1.33	3200DS-02	2	Screw M3 x 8
1.39	WD87	1	Motor Base
1.40	WD165	1	Gasket
1.41	WD150	1	Gasket
1.42	WD10	1	Base Cover
1.43	3238DS-01	6	Screw M5 x 16
1.44	WD9	1	Float
1.45	WD8	1	Float Frame
1.46	WD37	2	Spring
1.47	WD36	1	Filter Cartridge
1.48	WD35	1	Hook

PF53 SCHEMATICS - PARTS LISTS

Filter Assesmbly

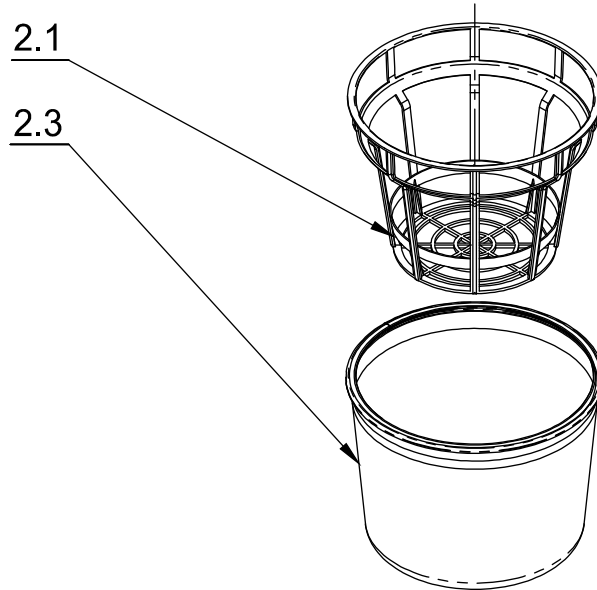

No.	Part No.	Qty	Description
2.1	WD7	1	Filter Frame
2.3	WD3	1	Filter and Gasket

PF53 SCHEMATICS - PARTS LISTS

Tank Assesmbly

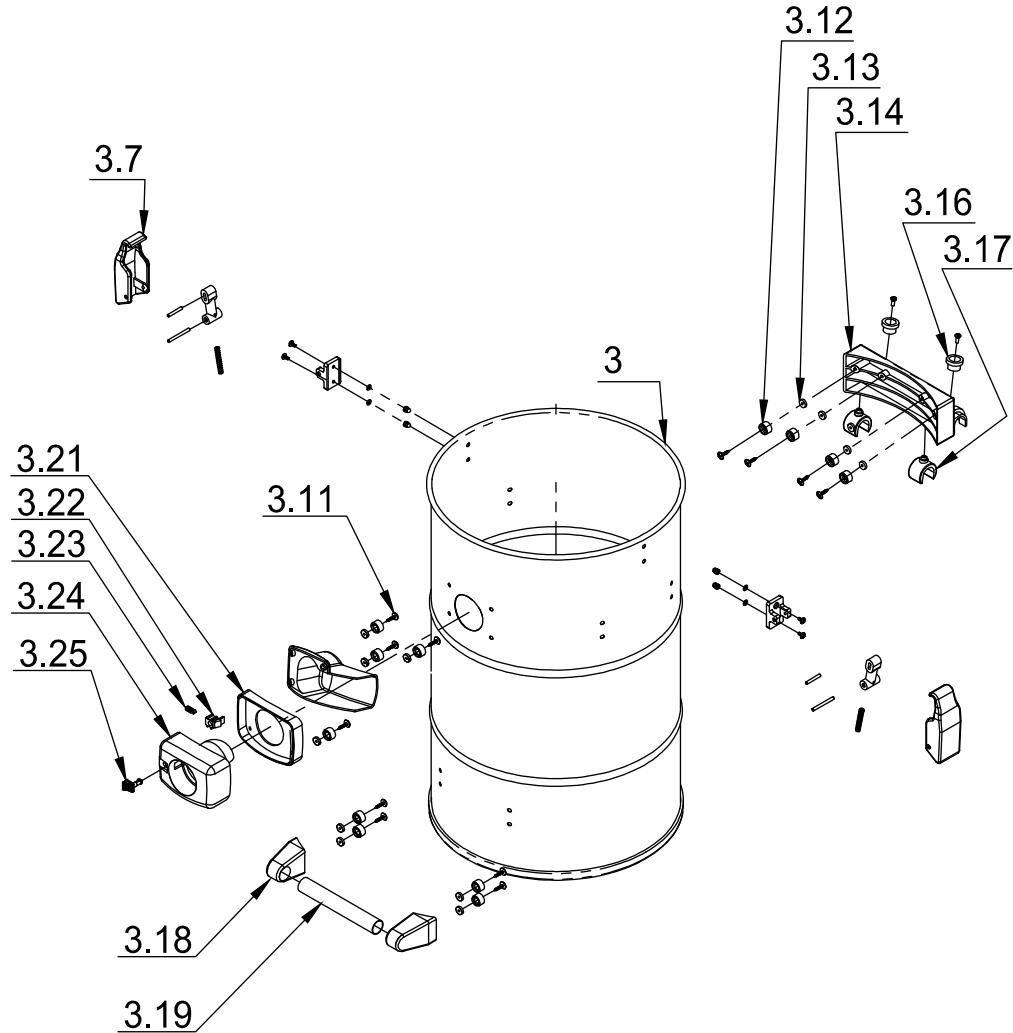

No.	Part No.	Qty	Description
3	WD38	1	Complete Tank Assembly
3.7	WD43	2	Latch Assembly
3.11	3238DS-06	9	Screw M5 x 25
3.12	WD77	12	Handle Spacer
3.13	WD76	12	Gasket
3.14	WD51	1	Plate
3.16	WD60	2	Lock Button
3.17	WD59	2	Lock Cover
3.18	WD225	2	Holder
3.19	WD226	1	Tip and Pour Handle
3.21	WD50	1	Washer
3.22	WD86	1	Button Base
3.23	WD47	1	Spring
3.24	WD45	1	Hose Coupler
3.25	WD46	1	Button

PF53 SCHEMATICS - PARTS LISTS

Dolly Asseembly

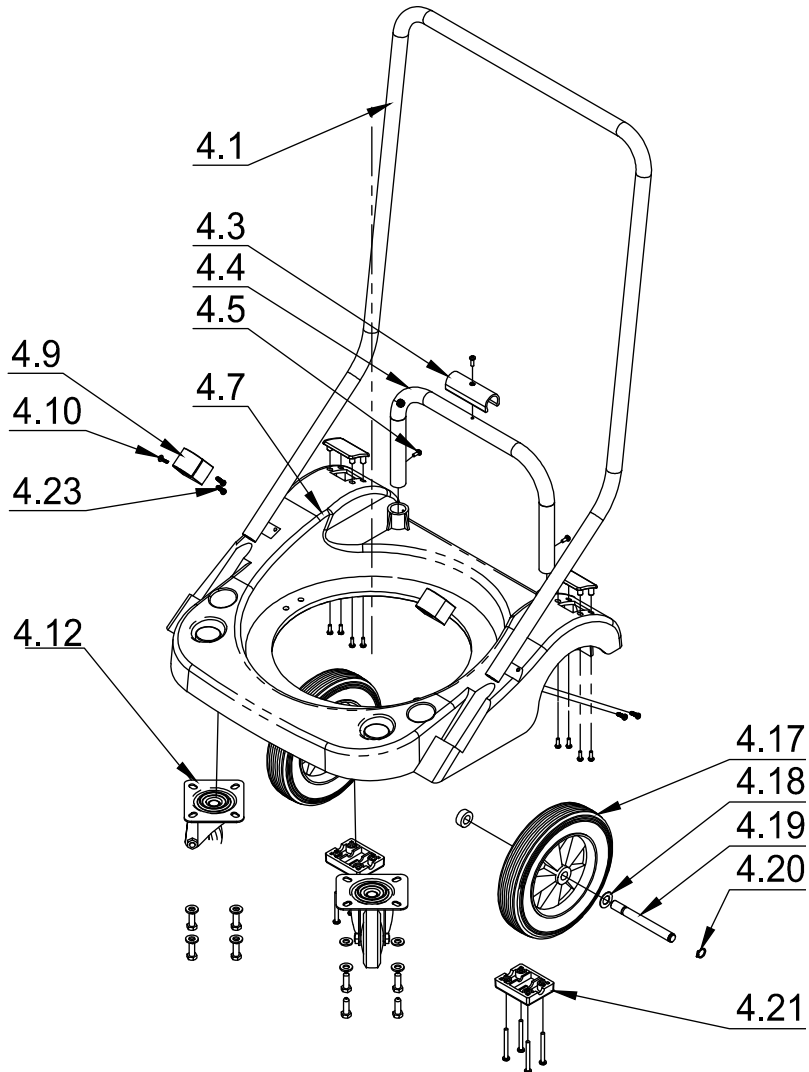

No.	Part No.	Qty	Description
4.1	WD78	1	Handle
4.3	WD217	1	Holder
4.4	WD80	1	Support
4.5	3238DS-02	2	Screw M5 x 12
4.7	WD62	1	Trolley Base
4.9	WD79	2	Holder
4.10	WD257	2	Screw M4 x 16
4.12	WD40M	2	Caster
4.17	WD123M	2	Wheel
4.18	WD229	2	Washer
4.19	WD81	2	Axle
4.20	WD126	2	C-Ring
4.21	WD173	2	Axle Plate
4.23	3208DS-01	4	Screw M4 x 18

PF53 SCHEMATICS - PARTS LISTS

Hose and Accessories

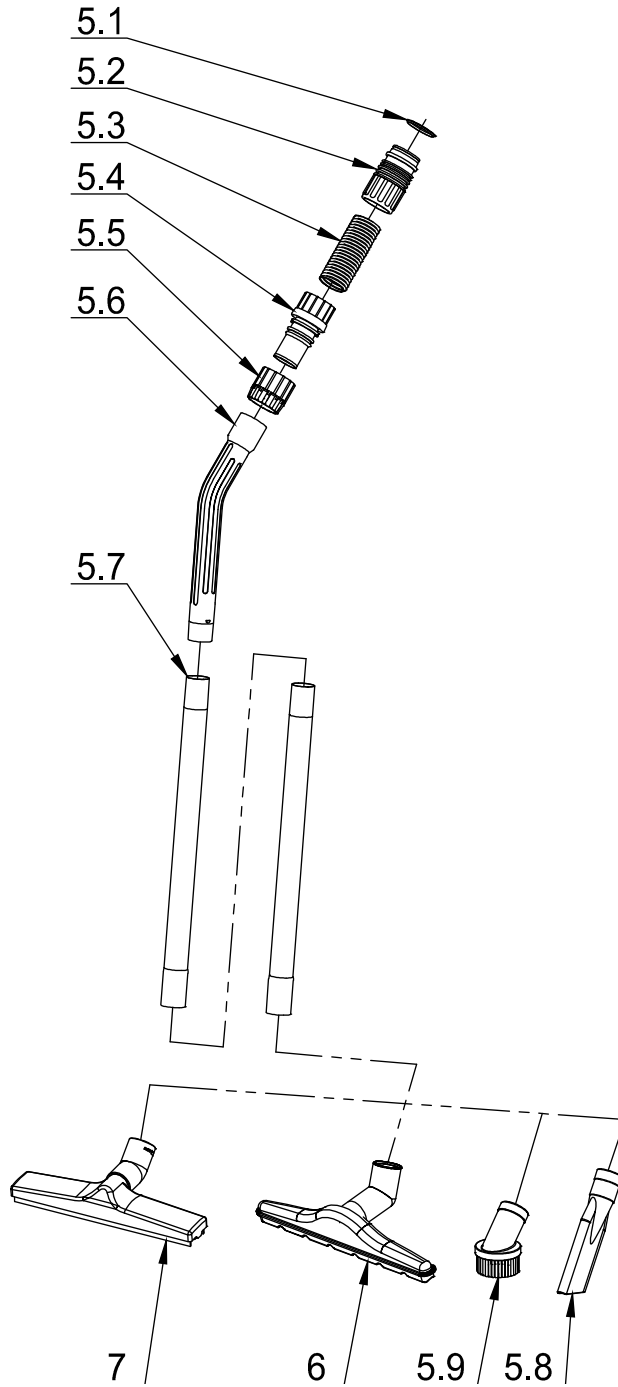

PF53 SCHEMATICS - PARTS LISTS

Hose and Accessories

No.	Part No.	Qty	Description
5.1	WD191	1	Seal
5.2	WD24	1	Hose Connector
5.3	WD25	1	Hose
5.4	WD26	1	Connector
5.5	WD27	1	Wand Holder
5.6	WD28	1	Bend Connector
5.7	WD29	2	Wand Section
5.8	WD32	1	Crevice Tool
5.9	WD33	1	Round Brush
6	WD30A	1	Squeegee Tool
7	WD112	1	Brush Nozzle Assembly

PF55 SCHEMATICS - PARTS LISTS

Head Assembly

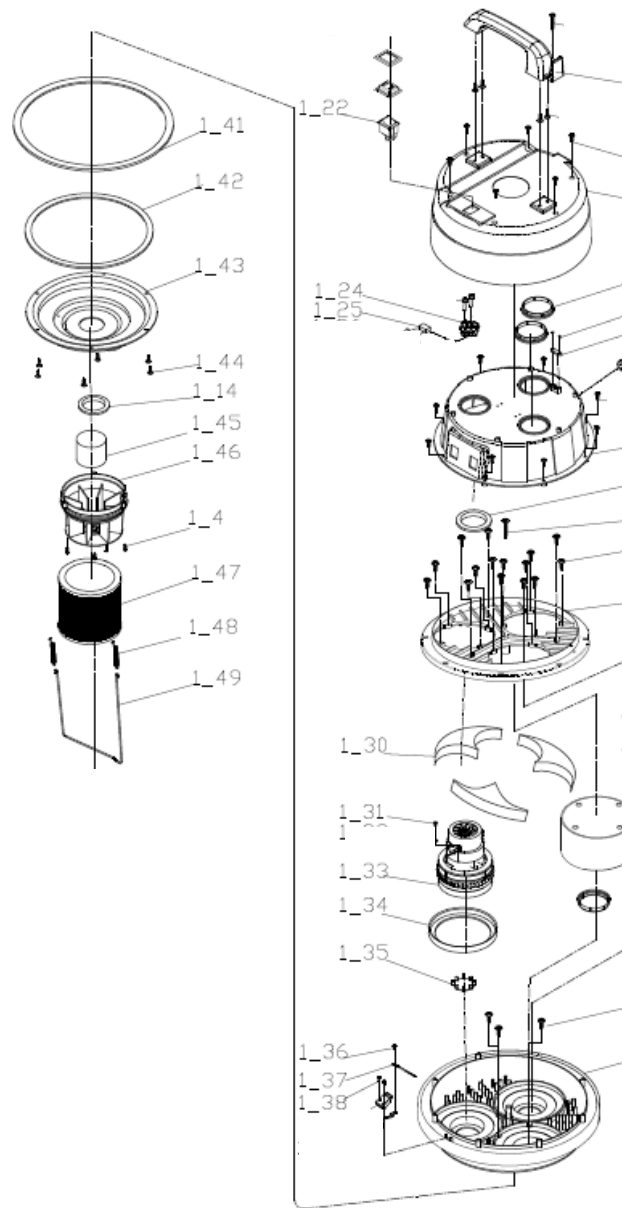

PF55 SCHEMATICS - PARTS LISTS

Head Assesmbly

No.	Part No.	Qty	Description
1.2	WD20A	1	Handle
1.4	3238DS-08	24	Screw M5 x 20
1.5	WD19	1	Top Cover
1.6	WD282	2	Bottom Block
1.7	3208DS-07	2	Screw M3.5 x 12
1.8	WD17	1	Wire Plate
1.9	wd66	1	Extension Cord
1.1	WD66C	1	Pig Tail
1.11	WD34	1	Strain Relief
1.13	WD16	1	Middle Seat
1.14	WD53	2	Gasket
1.16	WD14	1	Base
1.17	WD248	2	Blocker
1.18	WD83	2	Upper Blocker
1.19	WD11	1	Motor Seat
1.22	WD67	1	Switch
1.24	wd207	1	Terminal Block
1.25	3215BE-01	1	Capacitor
1.26	KK-01	2	Sleeve
1.3	WD56	3	Foam Gasket
1.31	3201DS-04A	1	Screw M4 x 10
1.33	WD150	1	Motor
1.34	WD68	1	Rubber Gasket
1.35	WD85	1	Stopper Plate
1.36	3208DS-07	1	Screw M3.5 x 12
1.37	5101BJ-01	1	Cable Tie
1.38	3200DS-02	2	Screw M3 x 8
1.41	WD210	1	Gasket
1.42	WD150	1	Gasket
1.43	WD10	1	Housing
1.44	3238DS-11	6	Screw M5 x 16
1.45	WD9	1	Float
1.46	WD8	1	Float Frame
1.47	WD36	1	Filter Cartridge
1.48	WD37	2	Spring
1.49	WD35	1	Hook

PF55 SCHEMATICS - PARTS LISTS

Filter Assesmbly

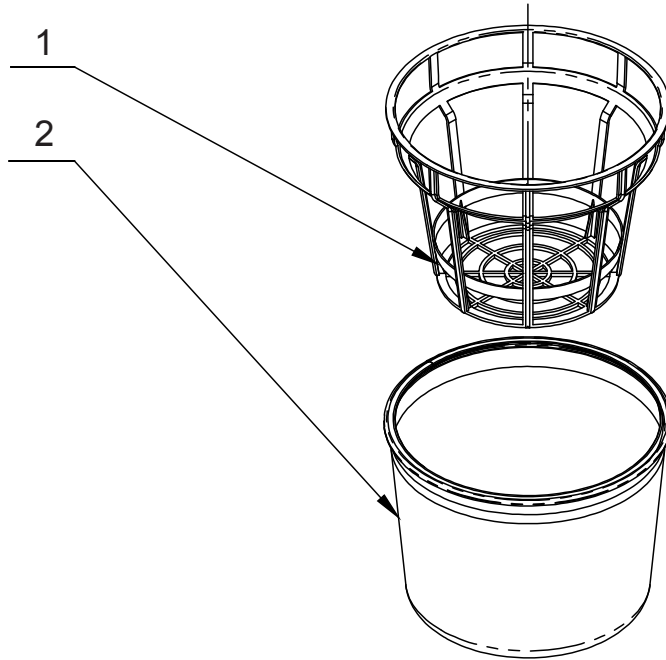

No.	Part No.	Qty	Description
1	WD7	1	Filter Frame
2	WD4	1	Filter and Gasket

PF55 SCHEMATICS - PARTS LISTS

Tank Assesmbly

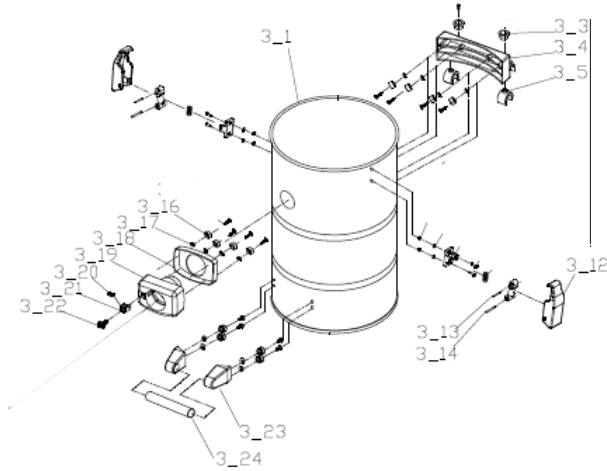

No.	Part No.	Qty	Description
3	WD1	1	Tank Assembly
3.3	WD60	2	Lock Buttom
3.4	WD51	1	Holder
3.5	WD59	2	Cover
3.12	WD43	2	Latch Assembly
3.13	WD129	2	Short Pin
3.14	WD131	2	Long Pin
3.16	WD77	12	Holder
3.17	WD76	12	Washer
3.18	WD50	1	Ruber Washer
3.19	WD45	1	Coupler
3.2	WD47	1	Spring
3.21	WD86	1	Switch Base
3.22	WD46	1	Button
3.23	WD225	2	Holder
3.24	WD226	1	Handle

PF55 SCHEMATICS - PARTS LISTS

Dolly Asseembly

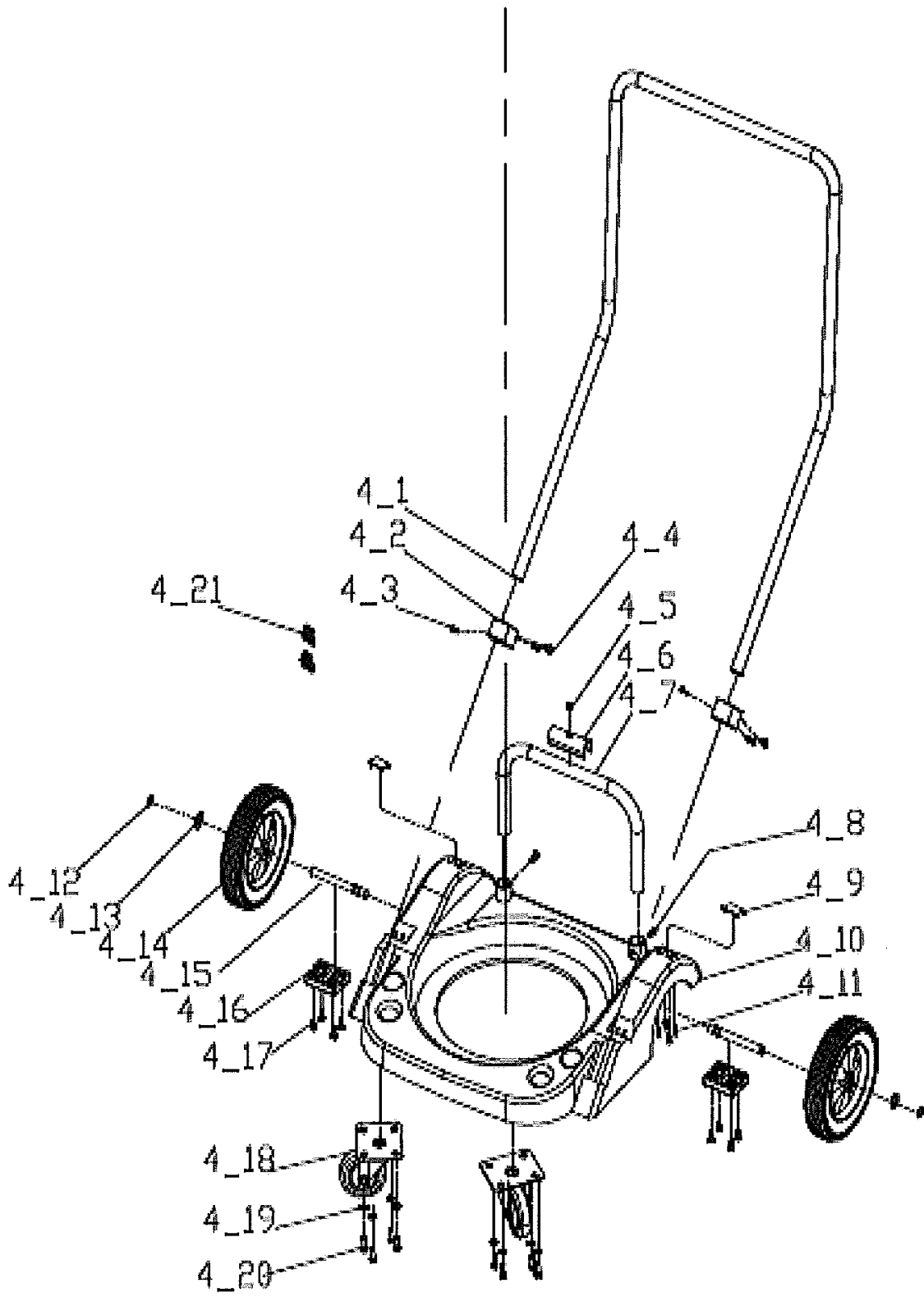

PF55 SCHEMATICS - PARTS LISTS

Dolly Assesmbly

No.	Part No.	Qty	Description
4	32386M-01	1	Trolley Ass'y
4_1	3238UU-01A	1	Handle
4_2	3238AA-08	2	Holder
4_3	3285DS-05	2	Screw M4 x 16
4_4	3208DS-01	4	Screw M4 x 18
4_5	3287DS-02	1	Screw M4 x 5
4_6	3238AA-10	1	Cover
4_7	3238UU-02	1	Supportor
4_8	3238DS-02	2	Screw M5 x 12
4_9	3238AA-44	2	Cover
4_10	3238AA-06	1	Trolley
4_11	3240DS-07	8	Screw M4 x 12
4_12	3238DWR-01	2	C-Ring
4_13	3238DW-01	4	Washer
4_14	3238BJ-02M	2	Rear Wheel
4_15	3238LS-01	2	Axle
4_16	3238AA-07	2	Plate
4_17	3238DS-12	8	Screw M5 x 50
4_18	3238BJ-01M	2	Front Caster
4_19	5101DW-02	8	Washer
4_20	3238DS-03	8	Screw M8 x 30
4_21	3239AA-18	2	Fixer

PF55 SCHEMATICS - PARTS LISTS

Hose and Accessories

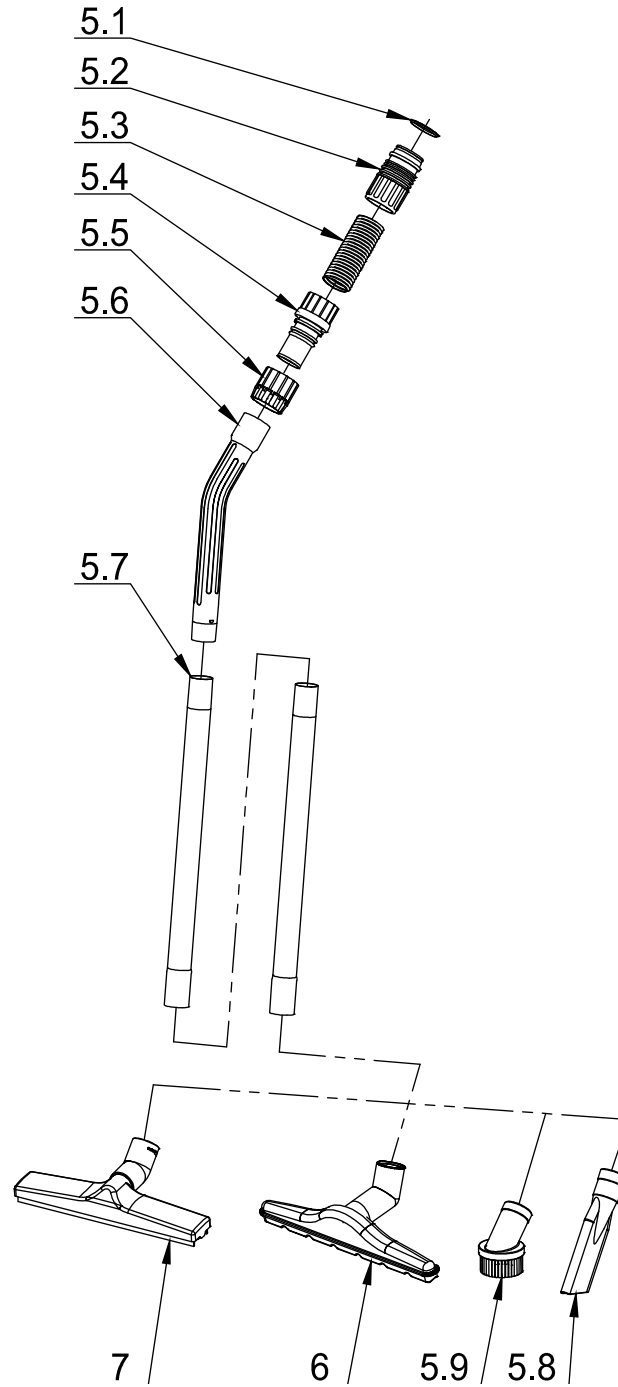

PF55 SCHEMATICS - PARTS LISTS

Hose and Accessories

No.	Part No.	Qty	Description
5.1	WD191	1	Seal
5.2	WD24	1	Hose Connector
5.3	WD25	1	Hose
5.4	WD26	1	Connector
5.5	WD27	1	Wand Holder
5.6	WD28	1	Bend Connector
5.7	WD29	2	Wand Section
5.8	WD32	1	Crevice Tool
5.9	WD33	1	Round Brush
6	WD30A	1	Squeegee Tool
7	WD112	1	Brush Nozzle Assembly

PF57 SCHEMATICS - PARTS LISTS

Head Assesmbly

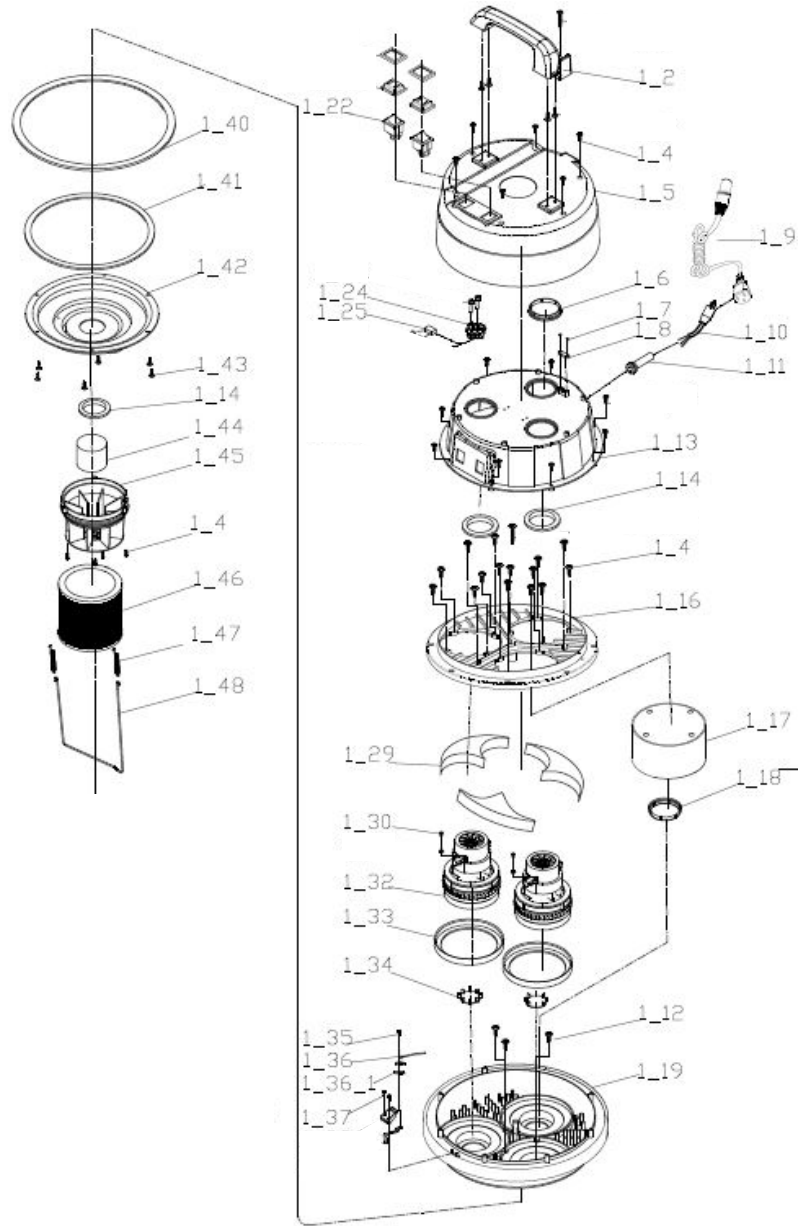

PF57 SCHEMATICS - PARTS LISTS

Head Assesmbly

No.	Part No.	Qty	Description
1.2	WD20	1	Handle
1.4	3238DS-08	24	Screw M5 x 20
1.5	WD19	1	Top Cover
1.6	WD282	2	Bottom Block
1.7	3208DS-07	2	Screw M3.5 x 12
1.8	WD17	1	Wire Plate
1.9	WD66	1	Extension Cord
1.10	WD66C	1	Pig Tail
1.11	WD34	1	Strain Relief
1.13	WD16	1	Middle Seat
1.14	WD53	2	Gasket
1.16	WD14	1	Base
1.17	WD248	1	Blocker
1.18	WD83	1	Upper Blocker
1.19	WD11	1	Motor Seat
1.22	WD22	2	Switch
1.24	WD207	1	Terminal Block
1.25	3215BE-01	1	Capacitor
1.29	WD56	3	Foam Gasket
1.30	3201DS-04A	1	Screw M4 x 10
1.32	WD150	2	Motor
1.33	WD68	1	Rubber Gasket
1.34	WD85	1	Stopper Plate
1.35	3208DS-07	1	Screw M3.5 x 12
1.36	5101BJ-01	1	Cable Tie
1.37	3200DS-02	2	Screw M3 x 8
1.40	WD210	1	Gasket
1.41	WD150	1	Gasket
1.42	WD10	1	Housing
1.43	3238DS-11	6	Screw M5 x 16
1.44	WD9	1	Float
1.45	WD8	1	Float Frame
1.46	WD36	1	Filter Cartridge
1.47	WD37	2	Spring
1.48	WD35	1	Hook

PF57 SCHEMATICS - PARTS LISTS

Filter Assesmbly

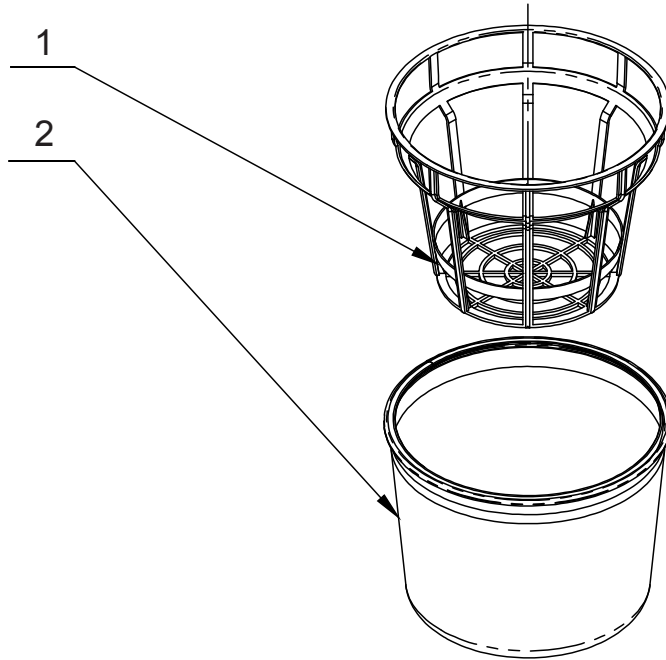

No.	Part No.	Qty	Description
1	WD7	1	Filter Frame
2	WD4	1	Filter and Gasket

PF57 SCHEMATICS - PARTS LISTS

Tank Assesmbly

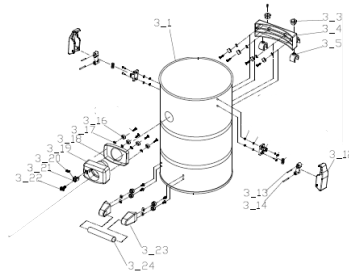

No.	Part No.	Qty	Description
3	WD1	1	Tank Assembly
3.3	WD60	2	Lock Buttom
3.4	WD51	1	Holder
3.5	WD59	2	Cover
3.12	WD43	2	Latch Assembly
3.13	WD129	2	Short Pin
3.14	WD131	2	Long Pin
3.16	WD77	12	Holder
3.17	WD76	12	Washer
3.18	WD50	1	Ruber Washer
3.19	WD45	1	Coupler
3.2	WD47	1	Spring
3.21	WD86	1	Switch Base
3.22	WD46	1	Button
3.23	WD225	2	Holder
3.24	WD226	1	Handle

PF57 SCHEMATICS - PARTS LISTS

Dolly Assesmbly

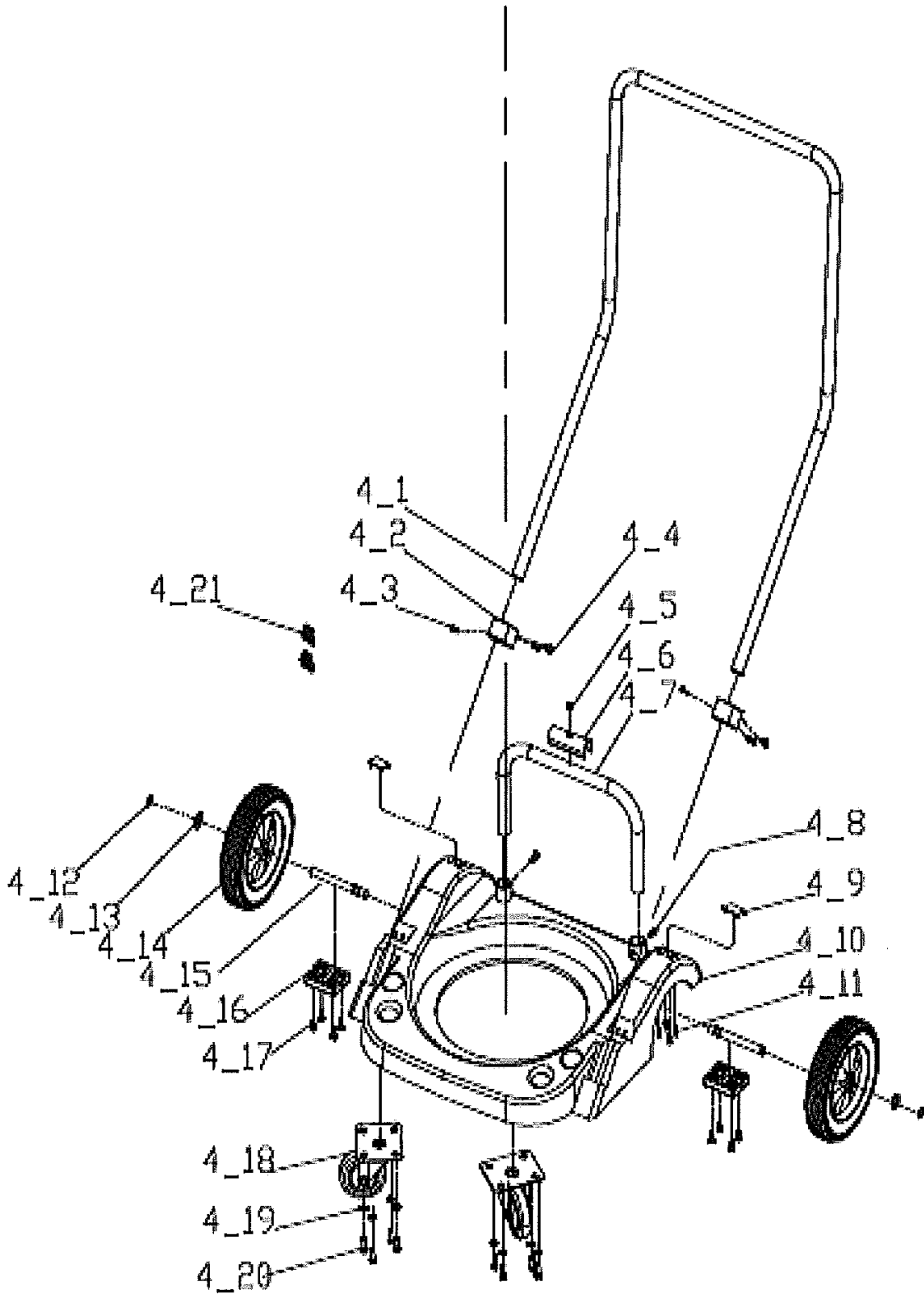

PF57 SCHEMATICS - PARTS LISTS

Dolly Assesmbly

No.	Part No.	Qty	Description
4	32386M-01	1	Trolley Ass'y
4_1	3238UU-01A	1	Handle
4_2	3238AA-08	2	Holder
4_3	3285DS-05	2	Screw M4 x 16
4_4	3208DS-01	4	Screw M4 x 18
4_5	3287DS-02	1	Screw M4 x 5
4_6	3238AA-10	1	Cover
4_7	3238UU-02	1	Supportor
4_8	3238DS-02	2	Screw M5 x 12
4_9	3238AA-44	2	Cover
4_10	3238AA-06	1	Trolley
4_11	3240DS-07	8	Screw M4 x 12
4_12	3238DWR-01	2	C-Ring
4_13	3238DW-01	4	Washer
4_14	3238BJ-02M	2	Rear Wheel
4_15	3238LS-01	2	Axle
4_16	3238AA-07	2	Plate
4_17	3238DS-12	8	Screw M5 x 50
4_18	3238BJ-01M	2	Front Caster
4_19	5101DW-02	8	Washer
4_20	3238DS-03	8	Screw M8 x 30
4_21	3239AA-18	2	Fixer

PF57 SCHEMATICS - PARTS LISTS

Hose and Accessories

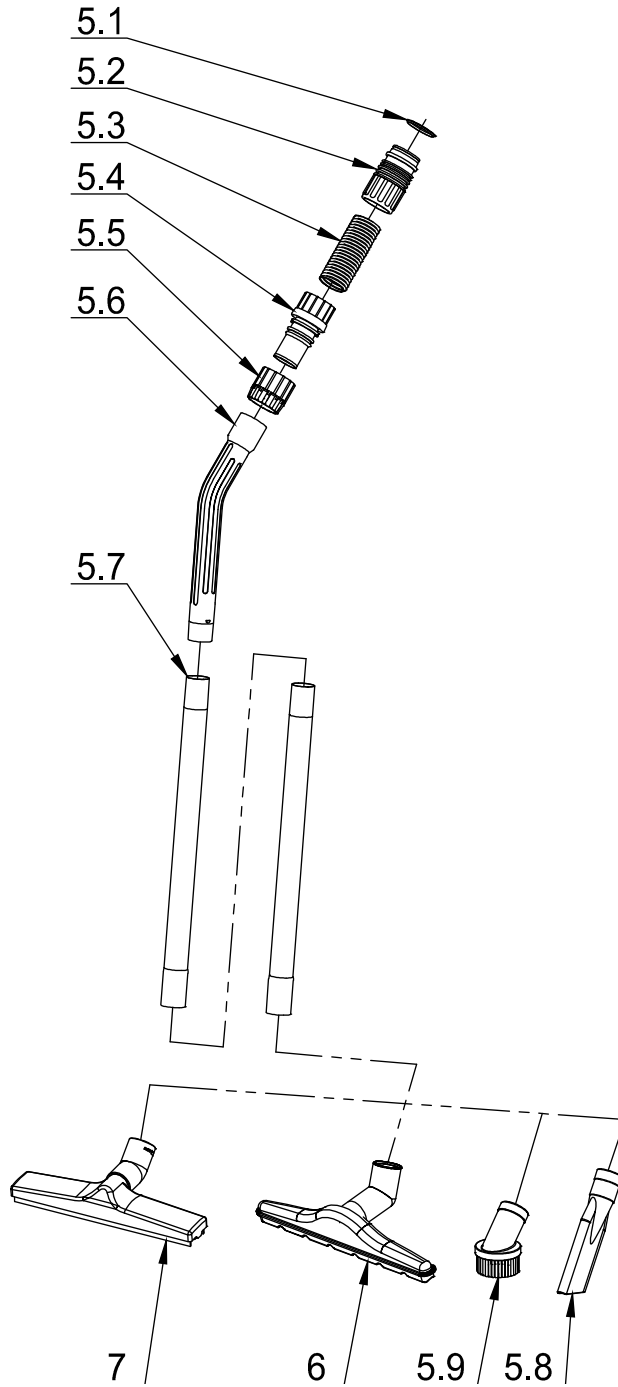

PF57 SCHEMATICS - PARTS LISTS

Hose and Accessories

No.	Part No.	Qty	Description
5.1	WD191	1	Seal
5.2	WD24	1	Hose Connector
5.3	WD25	1	Hose
5.4	WD26	1	Connector
5.5	WD27	1	Wand Holder
5.6	WD28	1	Bend Connector
5.7	WD29	2	Wand Section
5.8	WD32	1	Crevice Tool
5.9	WD33	1	Round Brush
6	WD30A	1	Squeegee Tool
7	WD112	1	Brush Nozzle Assembly

For warranty information go to www.Powr-Flite.com

Powr-Flite[®]

A Tacony Company

3101 Wichita Court • Fort Worth, TX 76140-1755

1-800-880-2913 • Fax: 1-817-551-0719