

# WET/DRY VACUUMS

## Parts for Commercial Vacs

### Powr-Flite Wet/Drys Vacuums 10 Gallon PF10, PF26, PF35, PF39, PF40

20 Gallon PF20, PF25, PF27

### Hazardous Material Vacuums

10 Gallon PF35HM, PF39HM,  
20 Gallon PF25HM, PF27HM

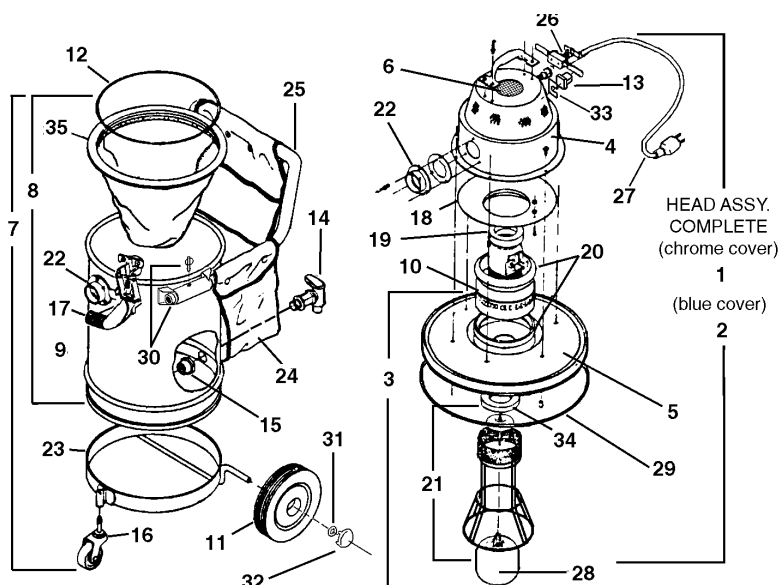

## HEAD ASSEMBLIES

ref#	order	description
2	<b>C8M</b>	head assembly complete with blue cover and blower port, models PF10, PF26, PF39, PF40
	<b>C81M</b>	head assembly complete PF35SR
	<b>C82M</b>	head assembly complete PF25SR
2	<b>C15M</b>	head assembly, complete with blue cover and blower port, models PF20, PF27
1	<b>C84M</b>	head assembly, complete with chrome cover and blower port, models PF25
1	<b>C96M</b>	head assembly, complete with chrome cover and blower port, models PF35
1	<b>HM7</b>	head assembly, model PF35HM

## COVER ASSEMBLIES

ref#	order	description
3	<b>C9M</b>	blue cover assembly, complete with float cage, models PF10, PF26, PF39, PF40
4	<b>C12M</b>	top dome assembly with blower port and handle, all models
5	<b>C16M</b>	blue cover only, models PF20, PF27
3	<b>C30M</b>	chrome cover assembly, complete with float cage, models PF25
3	<b>C42M</b>	blue cover only, models PF10, PF26, PF39, PF40
6	<b>C79M</b>	blower screen (to direct air), all models
4	<b>C83M</b>	chrome cover only, models PF25
4	<b>C97M</b>	chrome cover assembly, complete with float cage, models PF35

## CAN ASSEMBLIES

ref#	order	description
7	<b>C39M</b>	can assembly, complete with hardware and wheels, models PF20, PF27, PF27HM
7	<b>C40M</b>	can assembly, complete with wheels, dolly and handle, models PF10, PF26, PF39, PF39HM, PF40
8	<b>C41M</b>	can assembly, with hardware and handle, no dolly or wheels, models PF10, PF26, PF39, PF39HM, PF40

## CAN ASSEMBLIES

Cont.

ref#	order	description
7	<b>C91M</b>	20 gauge stainless can assembly, complete with hardware and wheels, models PF25, PF25HM
7	<b>C99M</b>	20 gauge stainless can assembly, complete with hardware and wheels, models PF35, PF35HM

## COMPONENT PARTS

ref#	order	description
10	<b>1969</b>	lamb motor, 220V
10	<b>1987</b>	lamb motor, 110V
	<b>AA140</b>	1-1/4" machine end hose coupling
	<b>AA141</b>	1-1/2" machine end hose coupling
	<b>AA150B</b>	1-1/2" x 10' hose, complete, blue
	<b>AA153</b>	1-1/4" x 7' hose, complete grey
	<b>AA170</b>	50' roll 1/4" x 7/8" gasket
	<b>SW140</b>	power head plug, black 13" 18/3
11	<b>C5M</b>	wheels
12	<b>C10M</b>	filter ring for 10 gallon filter
12	<b>C11M</b>	filter ring for 20 gallon filter
13	<b>PX49</b>	receptacle, power nozzle
	<b>C20M</b>	vinyl coated wire hose cage, 10 gallon units
14	<b>C21M</b>	plastic drain valve
15	<b>C22M</b>	drain valve flange
16	<b>C23M</b>	caster
	<b>C25M</b>	clamp assembly
	<b>C26M</b>	vinyl coated wire hose cage, 20 gallon units
18	<b>C27M</b>	motor adaptor
19	<b>C28M</b>	top motor gasket
20	<b>C29M</b>	motor gasket
21	<b>C31M</b>	float cage assembly
22	<b>C32M</b>	inlet fitting
23	<b>C34M</b>	dolly body, 20 gallon units
24	<b>C35M</b>	tool caddy, 20 gallon units
25	<b>C36M</b>	2 position push handle for 20 gallon unit
26	<b>SW1507</b>	toggle switch
27	<b>C38M</b>	line cord
31	<b>C801M</b>	axle washer

CONTINUED ON NEXT PAGE

# WET/DRY VACUUMS

## Parts for Commercial Vacs / Squeegee, Wands

ref#	order	description
23	C43M	dolly body, 10 gallon units
	C51M	gasket for AA140, AA141
29	C54M	top seal gasket
28	C70M	float ball only
30	C75M	pin and ring assembly for 2 position handle
	C823M	side handle bracket
	C86M	panel nut for C5M
32	C87M	hub cap for C5M
	C89M	retainer clip for C17M
	C90M	strain relief
	C92M	tool caddy, 10 gallon units
34	C94M	gasket for float ball
25	C98M	2 position push handle, 10 gallon units
	CT10	1-1/2" concrete tool, 12" wide mouth picks up debris quick and easy; use with CT9, CT14
	CT11	1-1/2" tapered dusting brush, cast aluminum, 3" wide
	CT11R	dust brush refill for CT11
	CT12	1-1/2" overhead pipe tool, 4" to 6" diameter, use with CT6, CT7, CT15, or CT24 wands
	CT13	1-1/2" crevice tool, 15" long, polished chrome finish
	CT30	floor tool, complete, 14"
	CT31	squeegee tool, complete, 14"
	CT32	replacement floor brush for CT30
	CT33	replacement squeegee blade for CT31
	CT34	rug tool, complete, 14"
	CT35	replacement rug shoe for CT34
	CT39	replacement brass bristle
	CT41	1-1/4" squeegee tool
	CT45	1-1/2" metal upholstery tool
	CT51	double blade squeegee tool, complete, 14"
	CT52	claw tool less brush strip, for vacuuming of asbestos (comes with hazardous duty vacs)
	CT53	1-1/2" x 11" crevice tool (comes with hazardous duty vacs)
	CT54	replacement squeegee blades for CT51
	D407B	rug tool complete, 1-1/4" gray
	D408B	floor tool complete, 1-1/4" gray
	D409B	upholstery tool, 1-1/4" gray
	D410B	dusting brush, 1-1/4" gray
	D411B	crevice tool, 1-1/4" gray
	E529	2-way, deluxe rug tool, 1-1/4"
	H818	10 gallon cloth filter with gasket
	H819	20 gallon cloth filter with gasket
	HM1	2-ply, 5-pak, totally enclosed paper bag for 10 gallon units
	HM2	2-ply, 5-pak, totally enclosed paper bag for 20 gallon units
	HM3	intermediary glass filter, 2-pak, for 10 gallon units
	HM4	intermediary glass filter, 2-pak, for 20 gallon units
	HM5	14" HEPA filter
	HM6	16" HEPA filter
	399PB	paper bag with elastic top, 5-pak
	HMK1	conversion kit for wet pick up recovery, 20 gallon units
	HMK2	conversion kit for wet pick up recovery, 10 gallon units
	C101M	4562 5pk paper bag for 20 gallon units

## WANDS

order	description
CT14	1-1/2"x54" 2 piece chromed wand set
CT24	1-1/2"x54" 2 piece aluminum wand set*
C24M	lock ring for above wands*
C93M	screw on coupling for above wands, except CT7*
L1207	1-1/4" slotted wand, straight
L1221	1-1/4" curved attachment end with swivel and suction control

\*Does not come with wet/dry vacuums.

## PARTS TO FIT PF86 POWR-JET SPRAYER

order	description
PS2A	replacement spray tip for PS2 wand
PC5	quick disconnect
PS8	pump #2100-595, 45 PSI
PS17	wand seat, brass and teflon

## CT100, CT200 SUPER SQUEEGEE ATTACHMENT

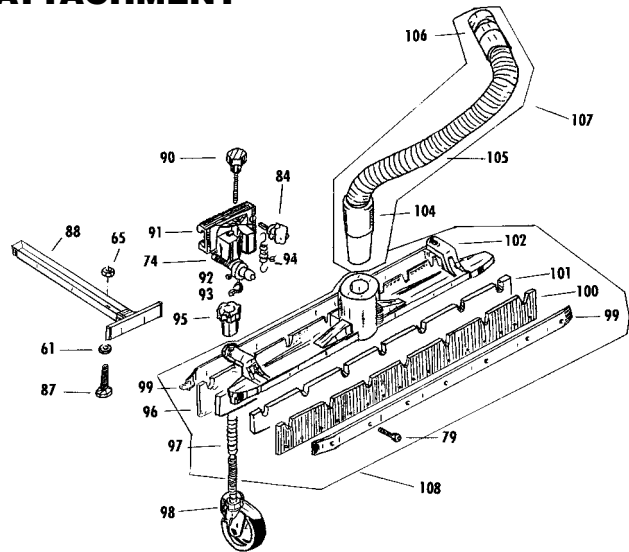

ref#	order	description
	CT200	squeegee tool, complete fits 20 gallon
	CT100	squeegee tool, complete fits 12 gallon
61	CT72	washer, diam. 6 x 24
65	CT73	nut M6
74	CT74	screw M8 x 35
79	CT75	screw M5 x 26
84	CT76	knob model A3/62 M6 x 20
87	CT77	screw TC M6 x 10
88	CT78	"T" iron for CT70
88	CT108	"T" iron for CT100
88	CT109	"T" iron for CT200
90	CT79	knob
91	CT80A	slider
92	CT81A	bushing
93	CT82A	plastic ring with hook
94	CT83A	spring
95	CT84	knob
96	CT85	rear squeegee blade, gray
97	CT86	spring 1, 2 x 30
98	CT87	wheel, complete
99	CT88	squeegee blade bracket
100	CT89	front squeegee blade (gray with holes)
101	CT90	spacer rubber (black)
102	CT91	frame for squeegee
104	CT92	hose end (ABS diam. 40)
105	CT93	hose only (diam. 40)
106	CT94	hose end (PVC diam. 40)
107	CT95	hose, complete with hose ends
108	CT96	squeegee body and blades
	NOT ILLUSTRATED	
	CT98	set screw for CT81A