

**SCHEMATIC USED
FOR THE FOLLOWING
MACHINES:**

PFX1085MAX	PFX1085MAX-2-AUS	-	-
PFX1085MAX-T	PFX1085MAX-2UK-SH	-	-
PFX1085MAX-2	PFX1085MAX-2XP	-	-
PFX1085MAX-2UK	PFX1085MAX-2XPD	-	-

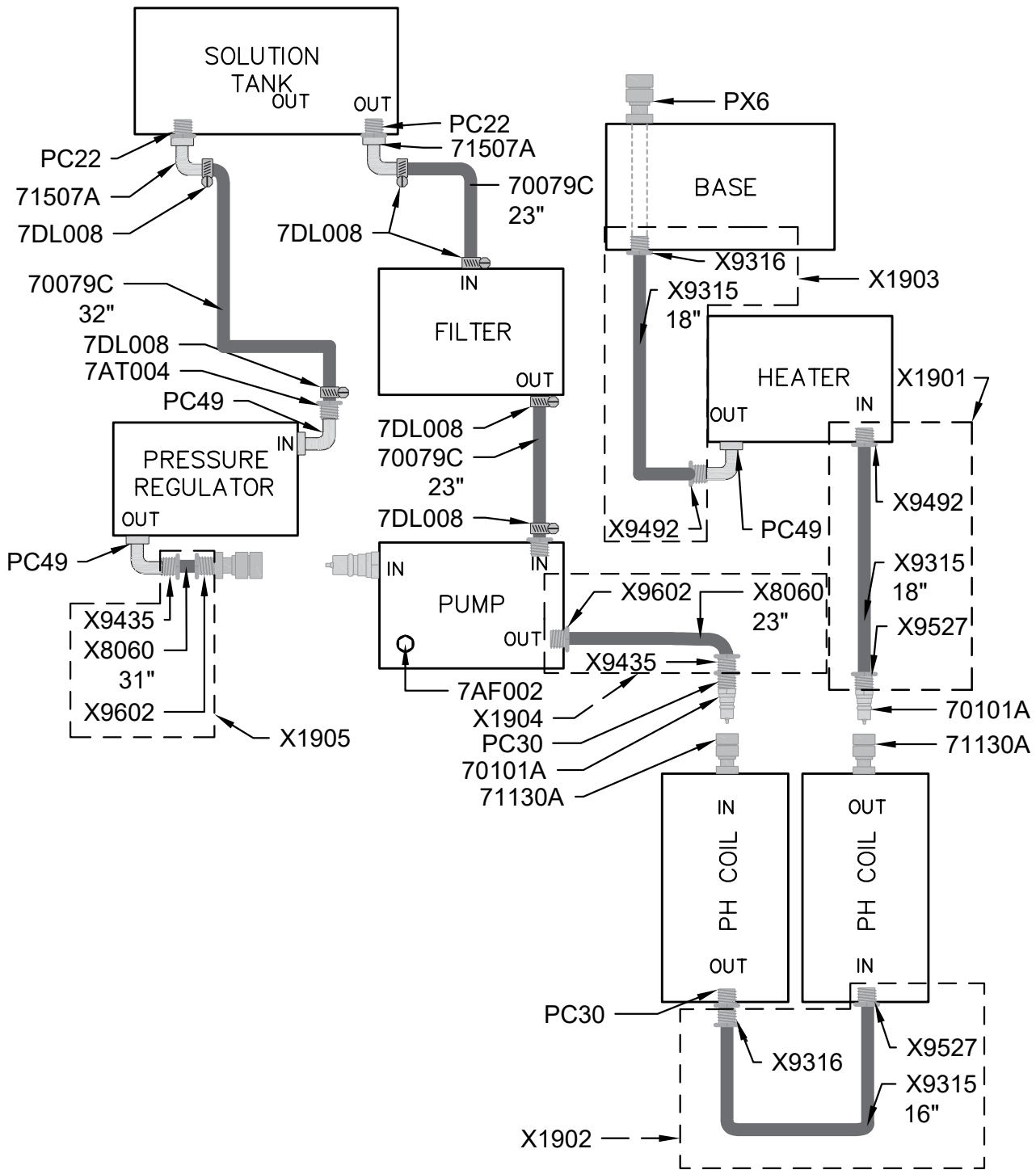

REV	DATE	ECN	DESCRIPTION	BY	<div style="display: flex; justify-content: space-between;"> <div> <p>Tacony</p> <p>COMMERCIAL FLOOR CARE EQUIPMENT</p> </div> <div> <p>3101 Wichita Court</p> <p>Fort Worth, TX 76140-1755</p> </div> </div>			
A	5/30/19	-	INITIAL RELEASE	VK				
-	-	-	-	-	DWN	VK	DATE	5/30/19
-	-	-	-	-	SOLUTION TANK	10 GALLONS	PSI	500
-	-	-	-	-	DESCRIPTION	HOSE LAYOUT HEATED		

POWR-FLITE CORPORATION CLAIMS PROPRIETARY RIGHTS IN THE MATERIAL DISCLOSED HEREIN. THIS DRAWING IS ISSUED FOR ENGINEERING INFORMATION ONLY. IT MAY NOT BE REPRODUCED, NOR MAY THE INFORMATION HEREIN BE USED FOR MANUFACTURING PURPOSES WITHOUT WRITTEN PERMISSION FROM POWR-FLITE CORP.