

Powr-Flite[®]

OPERATOR'S MANUAL & PARTS LIST

PFX1380 Upright Extractor



**WARNING: OPERATOR MUST READ AND UNDERSTAND THIS MANUAL
COMPLETELY BEFORE OPERATING THIS EQUIPMENT.**

IMPORTANT SAFETY PRECAUTIONS

WARNING!: To reduce the risk of fire, electric shock, or injury

WARNING
To avoid fire, **DO NOT**
use with a flammable
or combustible liquid
to clean floor.



WARNING
To avoid electric
shock, **DO NOT**
expose to rain.
Store Indoors.

When using this upright extractor, basic precautions should always be followed, including the following:

- 1) **DO NOT** leave unit when plugged in. Unplug from outlet when not in use and before servicing.
- 2) **DO NOT** allow unit to be used as a toy. Close attention is necessary when used around or near children.
- 3) Use only as described in this manual. Use only manufacturer's recommended attachments.
- 4) **DO NOT** use with damaged cord or plug. If unit is not working properly because it has been dropped, dropped into water, left outdoors, or damaged in any way, contact a service center of Powr-Flite.
- 5) **DO NOT** handle plug or appliance with wet hands.
- 6) **DO NOT** put any objects into openings. **DO NOT** use with any opening blocked: keep free of dust, lint, hair, or anything that may reduce air flow.
- 7) Keep hair, loose clothing, fingers, and all parts of body away from openings and moving parts.
- 8) **DO NOT** pick up anything that is smoking or burning such as cigarettes, matches, or hot ashes.
- 9) **DO NOT** use to pick up hazardous chemicals.
- 10) Turn off all controls before unplugging.
- 11) Turn unit off immediately if foam or liquid comes from machine exhaust. Empty & clean out recovery (dirty) tank and use defoamer to correct the problem.
- 12) **DO NOT** use to pick up flammable or combustible liquids such as gasoline or use in areas where they may be present.
- 13) **DO NOT** use where oxygen or anesthetics are used.
- 14) Replace damaged or worn parts immediately with genuine original equipment parts to maintain safety.
- 15) This unit must be connected to a properly grounded outlet only. See grounding instruction on page 3.

GROUNDING INSTRUCTIONS

DANGER: Improper use of the grounding plug can result in a risk of electric shock.

GROUNDING INSTRUCTIONS

This extractor must be properly grounded. If it should malfunction or breakdown, grounding provides a path of least resistance for electrical current to reduce the risk of electric shock. This machine is equipped with 1 or 2 pigtail cords having an equipment-grounding conductor and grounding plug. The pigtails must be inserted into an appropriate 12 gauge 3 prong extension cord.

GROUNDING METHODS

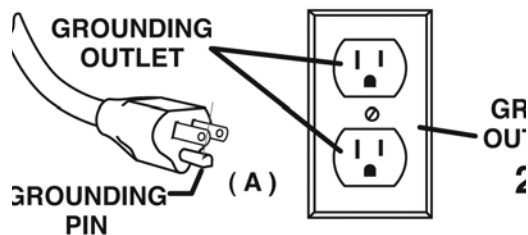

This unit is for use on a nominal 120 volt circuit and has a grounded plug that looks like the plug illustrated in (Fig. A).

WARNING!

Improper connection of the equipment-grounding conductor can result in a risk of electric shock. Check with a qualified electrician or service person if you are in doubt as to whether the outlet is properly grounded. **DO NOT** modify the plug provided with the appliance. If it will not fit the outlet, have a proper outlet installed by a qualified electrician.

General instructions for PFX1380 series Extractors

Congratulations on your purchase of a Powr-Flite extractor. You are now equipped to handle any and all commercial carpet cleaning jobs.

Shipping and Damage

This equipment is thoroughly inspected, tested, and packaged to provide equipment in good operating condition. It is beyond our control after the equipment is turned over to a freight carrier. The freight carrier received and signed for the equipment in good condition. Consequently, it is most important to protect your interest by carefully complying with the following instructions:

Please inspect your cartons for any damage (including concealed damage) that might have occurred during shipment. Any damage is the responsibility of the freight carrier and should be reported to the freight carrier immediately. It is your responsibility to issue a claim and to receive compensation from the freight carrier for any damage done in transit. Damage of this sort is not warranted.

Follow these easy step by step instructions to ensure proper operating performance.

1. Fill up the fresh water solution tank with tap water that is 120-135 degrees and approved carpet cleaning chemical if you are not pre-spraying your chemical on the carpet.
2. Attach two 12 gauge extension cords (NOT INCLUDED) (one cord for non-heated models) to each of the pigtail cords located on the lower backside of the unit. The red pigtail powers the heater while the black pigtail powers the vacuum motors and pump.
3. Plug each extension cord into a separate and grounded 20 amp wall socket circuit, when this is accomplished the green indicator light will be lit (on heated models).
4. Attach the hose system to the unit and to your carpet wand.
5. Turn on the heater and the pump to the "on" position, (only pump on non-heated models) when the heater is on the orange indicator light on the switch panel will be lit.
6. With the solution line attached to the wand and the machine, prime the pump by squeezing the trigger on the wand releasing the water (hold wand tip over solution tank to put water back into solution tank). This will pump water into the heater and get any air out of the solution line. Let the heater heat up this will take 3 to 5 minutes. *Prime pump on 400 p.s.i. models with prime hose (included).
7. Turn vacuum switches to the "on" position one at a time to begin cleaning.
8. Anyone designated to operate this equipment must, without fail, read and thoroughly understand all instructions and precautions prior to use.
9. Never use equipment out of doors or in the rain.
10. Never use flammable or explosive materials in or around this equipment!!!
11. When recovery tank is full, empty by using drain hose at rear of machine. If a pail is used to empty the recovery tank, do not use the same pail to fill the solution tank as this can result in putting dirt and grit into the solution line that can plug filters, orifices, and generally degrade the solution line system (do not reuse solution).
12. To empty solution tank, detach the wand from the end of the vacuum hose and insert the vacuum hose into the solution tank. Turn the vacuum switches to "on" position and transfer solution to vacuum tank and dispose of as outlined in #11. Clean vacuum stack filter at this time.

Maintenance

To receive reliable service from this equipment, regular daily maintenance is a required.

1. Keep the equipment clean, both inside and out.
2. Lubricate brass quick disconnects and drain valves with a quality lubricant such as WD-40®.
3. Flush solution systems after use with clear, clean water. (A white vinegar solution may also be used). This will counter-act hard water and alkaline deposits and aid in keeping orifices clean.
4. Do not allow fluid, either in solution or waste tank, to sit overnight. The unit should be emptied and cleaned daily.
5. Clean the strainer in the solution tank, the filters on the vacuum stack in vacuum tank, and all lint filters in the inlet or vacuum tanks daily.
6. Do not use the same receptacle (pail) to fill solution tank that is used to remove waste from vacuum tank.
7. When the unit is not in use, leave the vacuum tank lid open.
8. At the end of each day, run the vacuum for 3 minutes with lid open and filter off.

Safety Precautions

These precautions are designed with the safety of the operator, the equipment, and others in mind and must be followed at all times to avoid serious personal harm and/or death, and damage to the unit.

1. Always use a grounded electrical outlet.
2. Always disconnect electric cable from electrical outlet before attempting to make any adjustments or repairs.
3. Never use this equipment as a toy.
4. Never use equipment near or around flammable or explosive materials, fuels, or solvents.
5. Never put flammable materials, fuels, or solvents into equipment.
6. Never lift the machine by the drain hose.

7. Do not allow the unit to freeze!
8. The equipment was not designed to be used outdoors or in the rain.
9. Do not operate in standing water.
10. Wear safety equipment and clothing to protect from extremely hot water.
11. Do not operate equipment under any unsafe condition.
12. Do not operate if pigtails, hoses, etc. are cracked, frayed, leaking, or otherwise in need of repair.



Storage of Equipment

1. Store extractor indoors in dry area.
2. Recovery and solution tank should be empty and clean when the extractor is not in use.
3. Leave the recovery lid and dump valve open to air out the recovery tank.
4. Do not store in freezing temperature.
5. A small amount of windshield washer fluid available at an auto supply may be left in the pump and internal solution line for protection against freezing.



Warnings

1. Do not break off or pull the grounding prong on the plug.
2. Do not attempt repair on a warrantied machine unless instructions to perform it by an authorized shop are obtained from the factory.
3. Do not use citrus-based (D-Limonene) cleaners in this machine.
4. Do not use cleaning chemicals in this machine except those recommended for steam-type extraction equipment. The use of any chemicals with abrasive additives voids the warranty.
5. Do not use any replacement parts except those specified on the parts list. Performance of the machine could be affected if substitutions are made.
6. Do not use water in excess of 140° F (62° C) through the pump system. It could damage the seals and polypropylene casing of the diaphragm pump.
7. Follow maintenance schedule strictly.
8. Failure to comply with the above warnings instructions will void the warranty.

ONE LAST REMINDER

Read All Instructions, Warning and Cautions Before Using. These guidelines are presented for your protection and convenience. Please read them carefully, since failure to heed these precautions could result in discomfort or injury. When using an electrical appliance, basic safety precautions should always be followed.

WARNING

TO AVOID FIRE, DO NOT USE WITH A FLAMMABLE OR COMBUSTIBLE LIQUID TO CLEAN FLOOR.

MODEL PFX1380 SERIES CARPET EXTRACTOR PARTS

PFX1380 base assembly

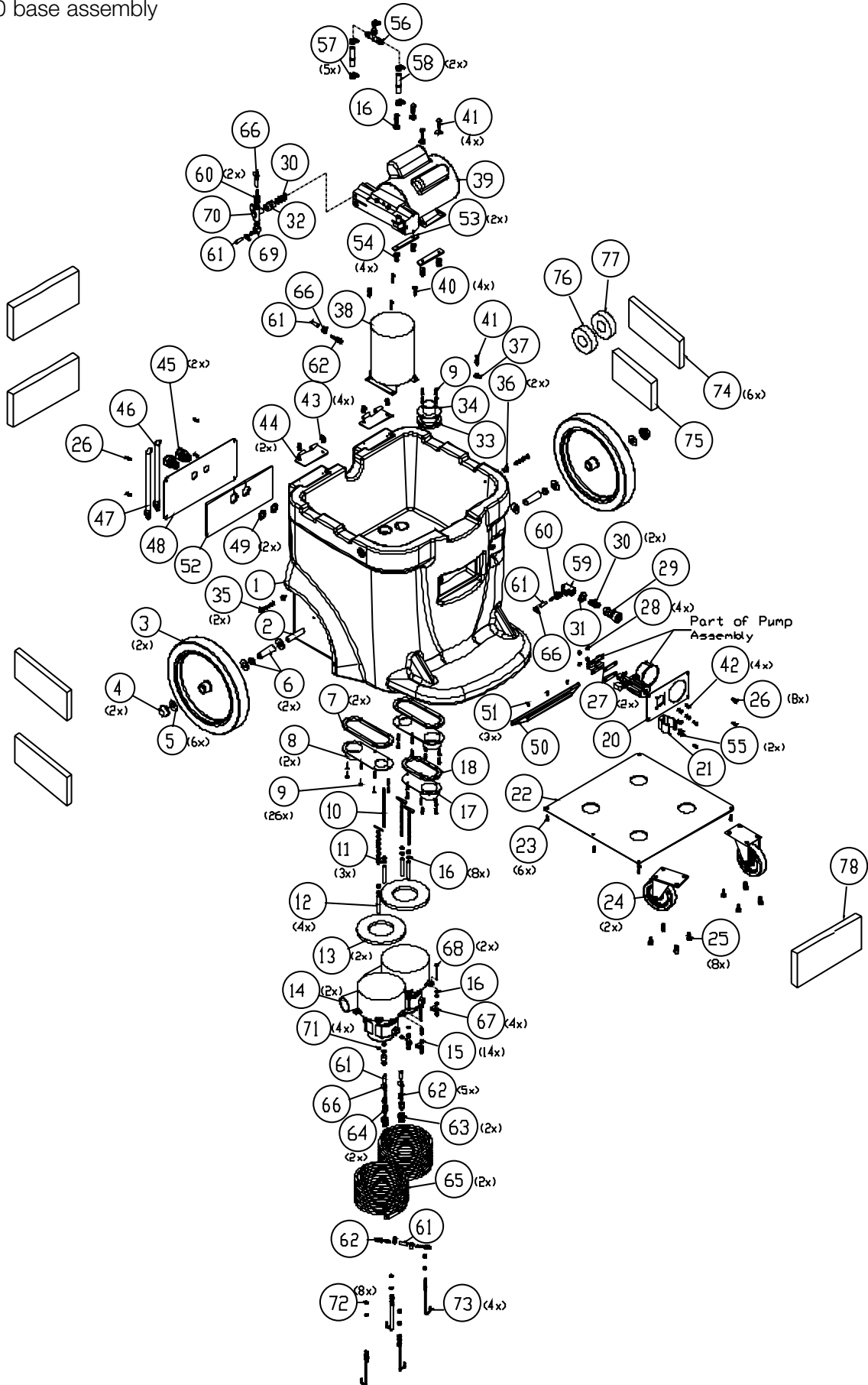

MODEL PFX1380 SERIES CARPET EXTRACTOR PARTS

PFX1380 base assembly

ref#	order#	description
1	72620AB	housing, base, black
2	72633A	axle
3	X9066	wheel, 12" x 1.75" non-marking,
	PX106B	wheel, 12" w/ 3/4" bore, all black
4	7GL002	push nut
5	7CM007	washer, 1/2 uss flat, 18-8 ss
6	72634A	bushing, 1/2" id x 3/4" od x 2-1/4" long
	72635A	spacer, 1/2" id x 3/4" od x 1/4" long
7	72640A	gasket, vac manifold, long
8	72623A	cover, vacuum manifold, long
9	7CW002	screw, #6 x 3/4 phil pan ts, type a 18-8 ss
10	72000A	rod, 3/16 x 5-1/2, all thread stud, 18-8 ss
11	72657A	screw, 10-24 x 4" long, hex head
	72658A	screw, 10-24 x 5" long, hex head
12	72651A	spacer, vac motor, 2.375" long
13	70020B	gasket, vacuum motor seal
14	1942-A	vacuum motor, 115 vac, 104 cfm, 2 stage
	72365	vacuum motor, 3 stage, 120v
15	7BF003	nut, kep, #10-24 zinc
16	7CM003	washer, #10 uss flat, 18-8 ss
17	72624A	cover, vacuum manifold, short
18	72641A	gasket, vac manifold, short
19	PX117A	gauge, 0-300 psi, 2-1/2", abs
	PC38	connector, double thread
20	72638A	pressure regulator plate
	X9157	cover, pressure regulator plate
21	72173A	spring clip, black vinyl coated
22	72636A	cover plate, bottom
23	72388A	screw, #10 x 5/8, tap phil, ss pan head
24	PX65	caster, 4" black

ref#	order#	description
25	72490A	screw, 5/16-18 x 5/8, cap screw w/ hex socket
26	72387A	screw, #8 x 5/8, black, tap phil, pan head
27	72639A	gasket, mounting pressure regulator
28	X8256	nut, 8-32 keps, zinc
29	70063B	coupler, valved 1/4, quick disconnect
30	7CX002	nipple, hex 1/4 mpt
31	72115A	washer, 5/8 x 1-3/16, bonded seal, galvanized
32	PC38	connector, double thread, female
33	72642A	gasket, vac manifold, circle
34	72625A	cover, vacuum manifold, circle
35	72627A	gasket, pump mounting
36	72626A	pump mounting plate
37	X9069	end loop, ss, w/ 2 holes, 16g
38	PF1750	heater unit, 1750 watts
	PF1200	heater, 1200w for low flow
	PF2000	heater, 2 1000 watt element (split)
39	PT400	pump, 200 psi w/regulator, 115v
	SF814	pump, 100 psi w/by-pass, epdm valves
	72643A	pump assembly, 500 psi w/ hoses
40	X9022	heater mounting bracket
41	X8236	screw, 10-24 x 1-1/4", phil pan ms, zinc
42	72020A	screw, #12 x 1", self-tap, phms zinc
43	7BS003	screw, 1/4-20 x 1/2, phil, pan, ms 18-8 ss
44	X9014	hinge
45	PD8	strain relief, 1/2" npt
46	PX112	pigtail, black, 12/3 sjt x 39" long
47	PR112R	pigtail, red, 12/3 sjt x 39" long
48	X9131	cord panel
49	X8008N	nut, lock, 1/2" steel conduit
50	7BS002	screw, 8-32 x 1/2 phil, pan ms, 18-8 ss

PFX1380 solution tank assembly

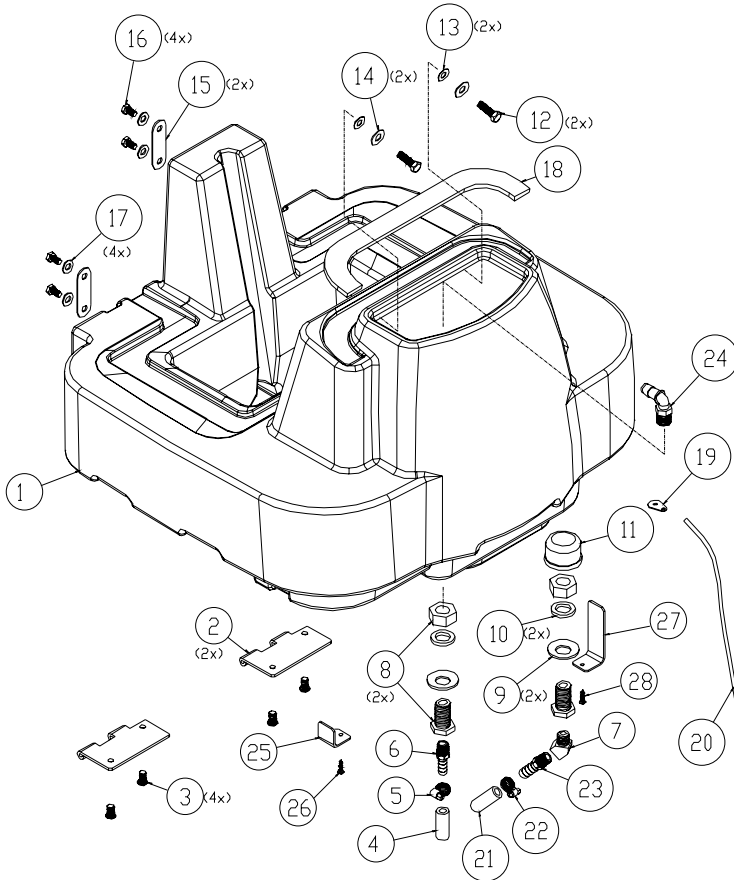

ref#	order#	description
1	X9112	Housing, Solution Tank
	X9112G	Housing, Solution Tank, Gray <i>For PFX1350B series models only</i>
2	X9014	Hinge
3	7BS003	Screw, 1/4-20x1/2" Phil Pan MS 18-8 SS
4	72031A	Hose, 3/8" Wire Reinforced PVC <i>Use PX3H+ (20.5" L) for 100 psi pump</i>
5	7DL003	Clamp, 1 1/4" Worm Gear Stainless Hex Slot phil <i>Use 2 for 200 psi pump</i>
6	PX85	Fitting, 1 1/4" MNPT x 3/8" Hose Male/Male Barb <i>Use two for 200 psi pump / Use 7AT004 for 400 psi pump</i>
7	PX17	Street Elbow, 45 deg. Brass, 1/4" NPT
8	PX18	Fitting, Brass, Bulkhead, 3/4"
		<i>Use only 1 for 100 psi pump</i>
9	72274A	Washer, 3/4" Neoprene-Bond, Galvanized <i>Use only 1 for 100 psi pump</i>
10	PX48G	Gasket, Fiber, 1.125 OD x .75 ID x .15625THK <i>Use only 1 for 100 psi pump</i>
11	X9294	Pump Protection Filter, SLS 1/2" FNPT 30x30 SST
12	71480AP	Bolt, 5/16-18 x 3/4" Hex, 18-8 SS
13	72667A	Washer, Rubber, .29ID, .688OD, .093Th
14	X9171	Washer, Flat 5/16 SS, .688OD, .344ID, .062Th
15	X9140	Tie Down Plate
16	7CP002	Bolt, 5/16-18x1/2" Hex Tap, 18-8 SS
17	X8235	Washer, 1/4" Flat USS Zinc
18	X9149	Gasket, Foam Strip, 1 x 14.25
19	X9069	End Loop, SS w/ 2 Holes, 16G
20	72660A	Rope, 22" Long
21	70079C	Hose, 1/2" Wire Reinforced <i>For 400 psi pump only; use 72031A for 200 psi pump</i>
22	7DL008	Clamp, 1 1/2" Worm Gear Stainless Hex Slot Phil <i>For 400 psi pump only</i>
23	7AT004	Barb, 1/2" Hose x 1/4" male <i>For 400 psi pump only</i>
24	PX15A	Fitting, Nylon Elbow, 90°, 1/4" NPT x 3/8" Hose barb
25	X9155	Latch, Bracket, Long
26	71644A	Screw #10 x 1" Phil Pan
27	X9156	Latch, Bracket, Short
28	71644A	Screw #10 x 1" Phil Pan

Troubleshooting Information

ELECTRICAL SYSTEM

PROBLEM	POSSIBLE CAUSE	SOLUTION
No electrical power.	1. Defective power cord. 2. Circuit breaker off or fuse blown.	1. Replace 2. Turn circuit breaker on or replace fuse. Unplug any equipment using the same circuit.
Switch is turned on. Intermittent power to motor(s).	1. Faulty electrical cable. 2. Defective switches. 3. Loose terminal or discolored terminal connections.	1. Repair or replace. 2. Replace. 3. Replace.
Electrical Shock	1. Equipment not grounded.	1. Locate grounded outlet.

VACUUM SYSTEM

PROBLEM	POSSIBLE CAUSE	SOLUTION
Vacuum motor on Little or no vacuum on wand head.	1. Drain hose open. 2. Defective vacuum hose Kinks in vacuum hose. 3. Vacuum disconnected.	1. Close drain hose. Recovery tank lid must be closed. 2. Repair or replace. 3. Open machine, connect vacuum hose to recovery tank.
Not enough vacuum power at the machine.	1. Damaged recovery tank lid. 2. Lint clogging ball - type shutoff screen. 3. Vacuum hose connection between stand pipe and vacuum motor. 4. Vacuum motor exhaust blocked. 5. Cords not plugged into separate circuits	1. Replace 2. Remove screen. Clean out fibers and accumulated dirt. 3. Check for leaks around clamps and cuffs (tighten). Replace damaged hose(s). 4. Check air flow by removing hose from machine and feel the exhaust under the machine. Remove obstruction. 5. Relocate one cord to a different room.

VACUUM SYSTEM

PROBLEM	POSSIBLE CAUSE	SOLUTION
Motor running and no vacuum at all.	1. Faulty vacuum motor.	1. Replace.
No exhaust from the blowport.	2. Water shutoff closed.	2. Clean water shutoff screen.
Premature closing of ball type shutoff.	1. Dirty or clogged shutoff filter screen.	1. Remove and clean screen.
Ball type shutoff failing to release after recovery tank is drained.	2. Ball coated with detergent or other foreign material. 3. Screen slightly out of round.	2. Remove and rinse ball with clean water. 3. Bend screen by squeezing slightly by hand until there is an obvious space between ball and inside of screen.

Foam/dirty solution coming out of vacuum exhaust port.	1. Foam from carpet by-passing water shutoff. 2. Elbow in vacuum tank is not positioned correctly.	1. Use additional defoamer. 2. The elbow should be pointed directly at the side wall of the tank away from the ball type shutoff.
--	---	--

SOLUTION SYSTEM

PROBLEM	POSSIBLE CAUSE	SOLUTION
Pump motor on – no spray through jets.	1. Clogged or faulty solution control valve. 2. Clogged or faulty quick disconnect on housing. 3. Punctured pump diaphragm. 4. Clogged jets	1. Check intake on valve and remove lint or other foreign material. 2. Depress plunger on solution hose against inside wall of solution tank. If solution is flowing at this point, the system is O.K. If no solution flows, check the quick disconnect for lint and other foreign matter. 3. Replace with diaphragm repair kit. 4. Clean jets on wand or tool.
Uneven spray from jet. Spray weak or uneven.	1. Clogged strainer in solution tank. 2. Clogged jet.	1. Unscrew strainer and remove lint and any other foreign material from screen. 2. Remove and clean.
Leaking or stuck solution valve.	1. Foreign material in valve. 2. Loose brass hex nut. 3. Valve worn or seals worn.	1. Remove brass hex plug, clean valve and replace. 2. Reseal hex and plug. 3. Replace worn parts with solution valve repair kit.
Pump motor not working.	1. Loose wiring 2. Defective pump pressure switch 3. Motor burnout	1. Tighten wiring 2. Replace with new pressure switch assembly 3. Replace pump motor
Pump pressure low	1. Clogged screens on 2. Punctured pump diaphragm. 3. Defective rectifier or motor. 4. Pump not primed	1. Unscrew strainer in solution tank remove lint and any other foreign material from screen. 2. Replace with diaphragm repair kit. 3. Replace. 4. Plug priming hose into solution connection and place end in solution tank. Run pump for 4 minutes
Pump pressure varies.	1. Worn carbon brushes. 2. Defective pump pressure control switch.	1. Replace brushes. 2. Replace.

WARRANTY

The manufacturer warrants to the original purchaser that products manufactured are free from defects of workmanship and material, provided such goods are installed, operated and maintained in accordance with written manuals or other instructions for a period of 5 years from date of purchase on housings and frame, 3 years on heater, 1 year on pump, vac motor, and parts and workmanship. In case you as our customer, meet any trouble with your machine, contact your Powr-Flite representative who will be happy to be of service to you and will take care of the warranty settlement.

NOTE: Alterations and changes made to the machine without written approval of the manufacturer and use of unapproved spare parts will not be covered by warranty.

Powr-Flite[®]

A Tacony Company
3101 Wichita Court • Ft. Worth, TX 76140-1755
1-800-880-2913 • Fax: 1-817-551-0719 • www.Powr-Flite.com