

Powr-Flite®

PARTS LIST

Phantom Automatic Scrubber

Model: PFS24



**WARNING: OPERATOR MUST READ AND UNDERSTAND THIS MANUAL
COMPLETELY BEFORE OPERATING THIS EQUIPMENT.**

Save These Instructions

PFS24 FRAME

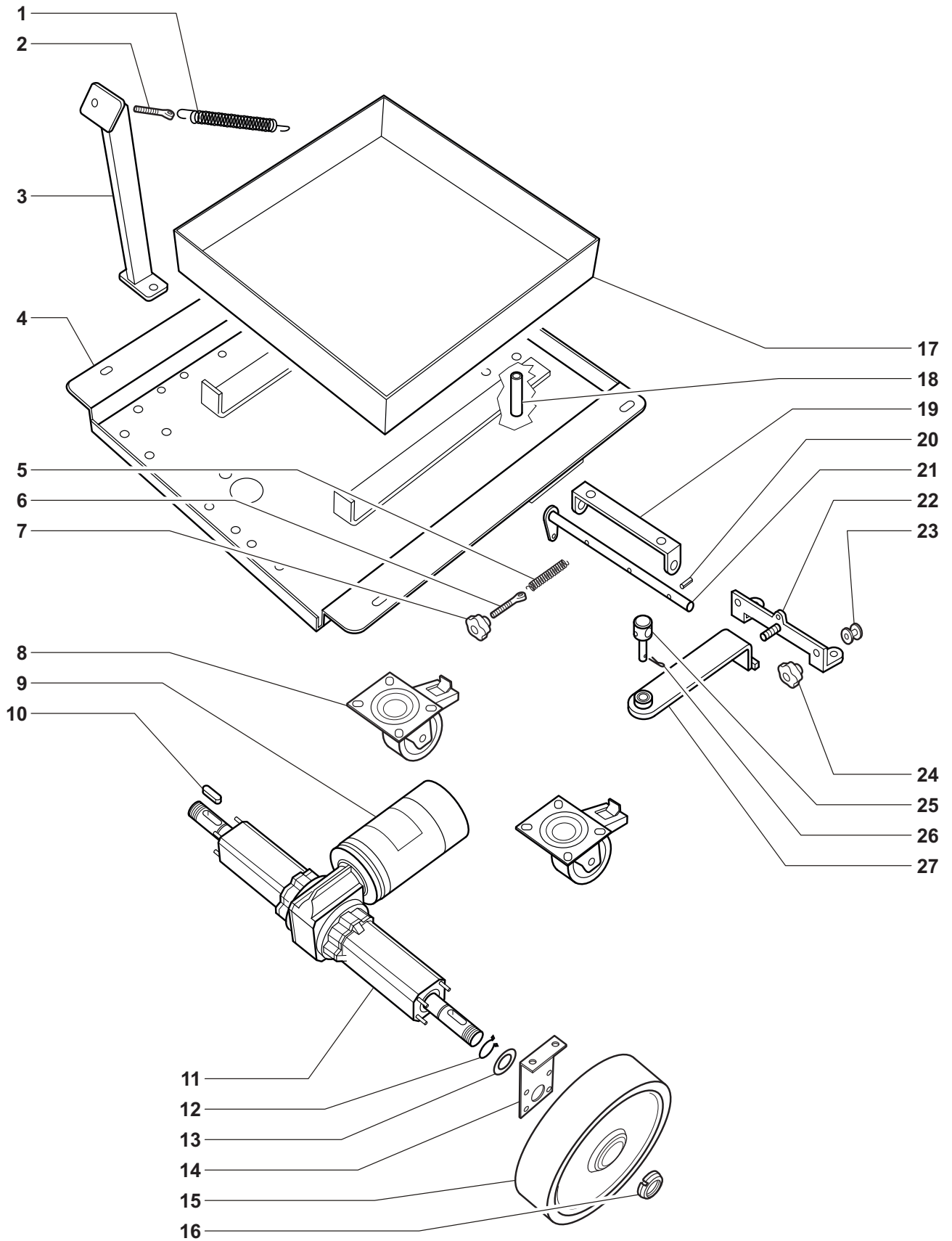

PFS24 FRAME

No.	Part No.	Qty	Description
1	PAS2031	1	Spring
2	PFS0001	1	Tie Rod
3	PFS0002	1	Support
4	PFS0003	1	Steel Frame
5	PFS0004	1	Spring
6	PAS63	1	Tie Rod
7	PAS33	1	Knob
8	PFS0005	2	Swivel Caster
9	PFS0006	1	Traction Motor
10	PAS101	2	Square Key
11	PFS0007	1	Complete Transaxle
12	PAS491	2	Seeger Ring
13	PAS356	2	Washer
14	PFS0008	2	Support
15	PAS298	2	Wheel
16	PAS358	2	Ring nut
17	PFS0009	1	Plastic Battery Tray
18	PFS0010	2	Rubber
19	PFS0011	1	Support
20	PFS0012	1	Pin
21	PFS0013	1	Shaft
22	PFS0014	1	Support
23	PAS34	1	Regulator
24	PAS33	1	Knob
25	PAS19	1	Pin
26	PAS266	1	Split Pin
27	505.097	1	Lever

PFS24 BRUSH HEAD

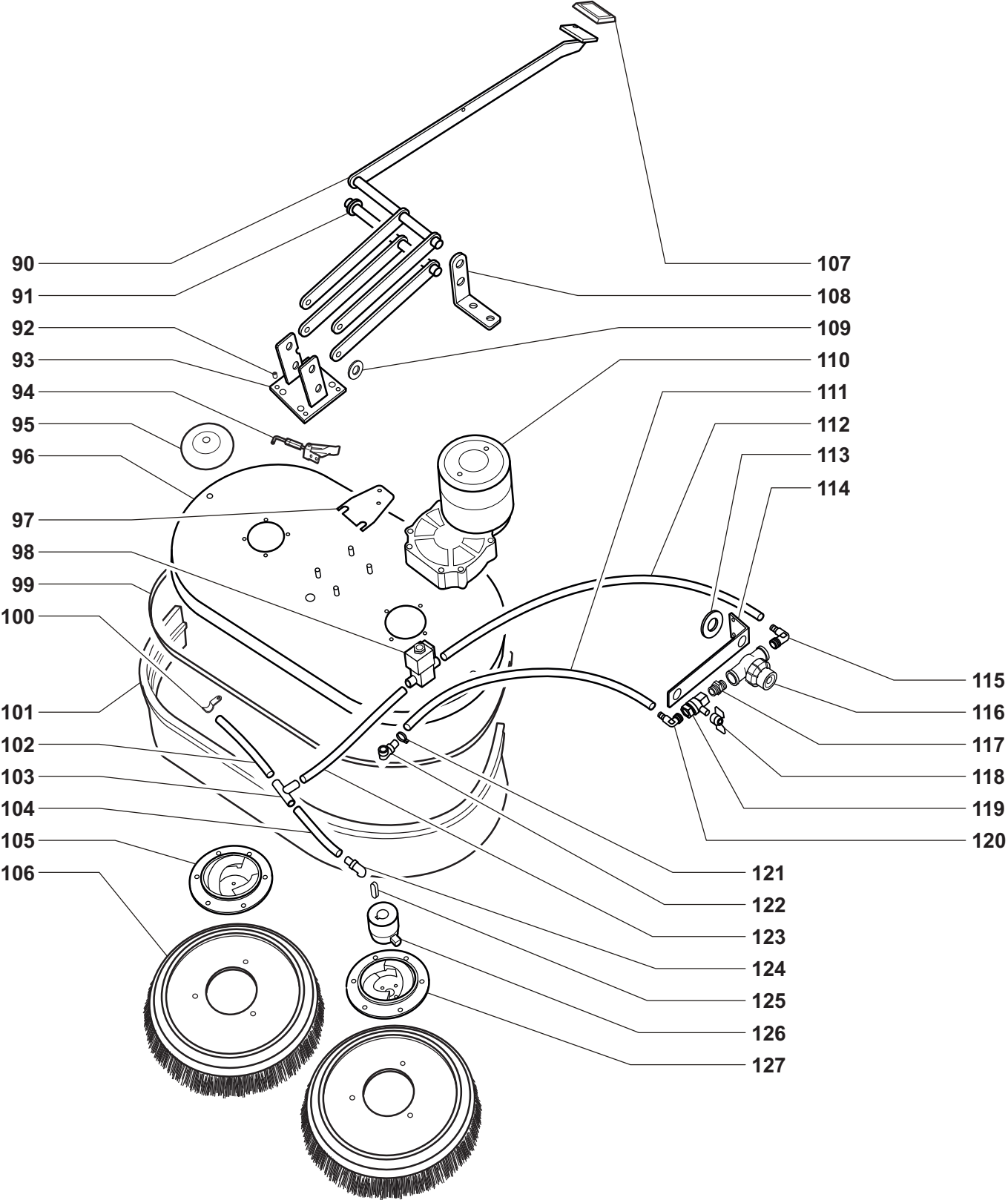

PFS24 BRUSH HEAD

No.	Part No.	Qty	Description
90	PFS0034	1	Lever
91	PFS0035	1	Lever
92	PFS0036	1	Dowel
93	PFS0037	1	Support
94	PAS122	1	Hook
95	PAS1	1	Bumper Wheel
96	PFS0038	1	Plate
97	PFS0039	1	Support
98	PAS2035	1	Solenoid Valve
99	PAS211	1	Retainer Strip
100	PAS2039	1	Pipe Support
101	PFS0040	1	Splash Guard
102	PFS0041	1	Hose
103	PAS82	1	Joint
104	PFS0042	1	Hose
105	PFSCPR	2	Clutch Plate Right
106	PFS12PDR	1	Pad Holder (Right)
	PFS12PDL	1	Pad Holder (Left)
107	PAS14	1	Pedal Cover
108	PAS2034	1	Support
109	PFS0016	1	Washer
110	PFS0033	1	Motor and Gearbox
111	PFS0043	1	Hose
112	PFS0044	1	Hose
113	PFS0028	1	Washer
114	PFS0024	1	Support
115	PAS296	1	Hose Fitting
116	PFS0025	1	Filter
117	PFS0026	1	Nipple
118	PAS2043	1	Solution Control Knob
119	PFS0027	1	Ball Valve
120	PAS296	1	Hose Fitting
121	PFS0030	1	Hose Clamp
122	PAS296	1	Hose Fitting
123	PFS0045	1	Hose
124	PAS2038	1	Hose Fitting
125	PFS0017	2	Square Key
126	PFS0018	2	Joint
127	PFSCPL	1	Clutch Plate Left

PFS24 TANKS and VACUUM MOTOR

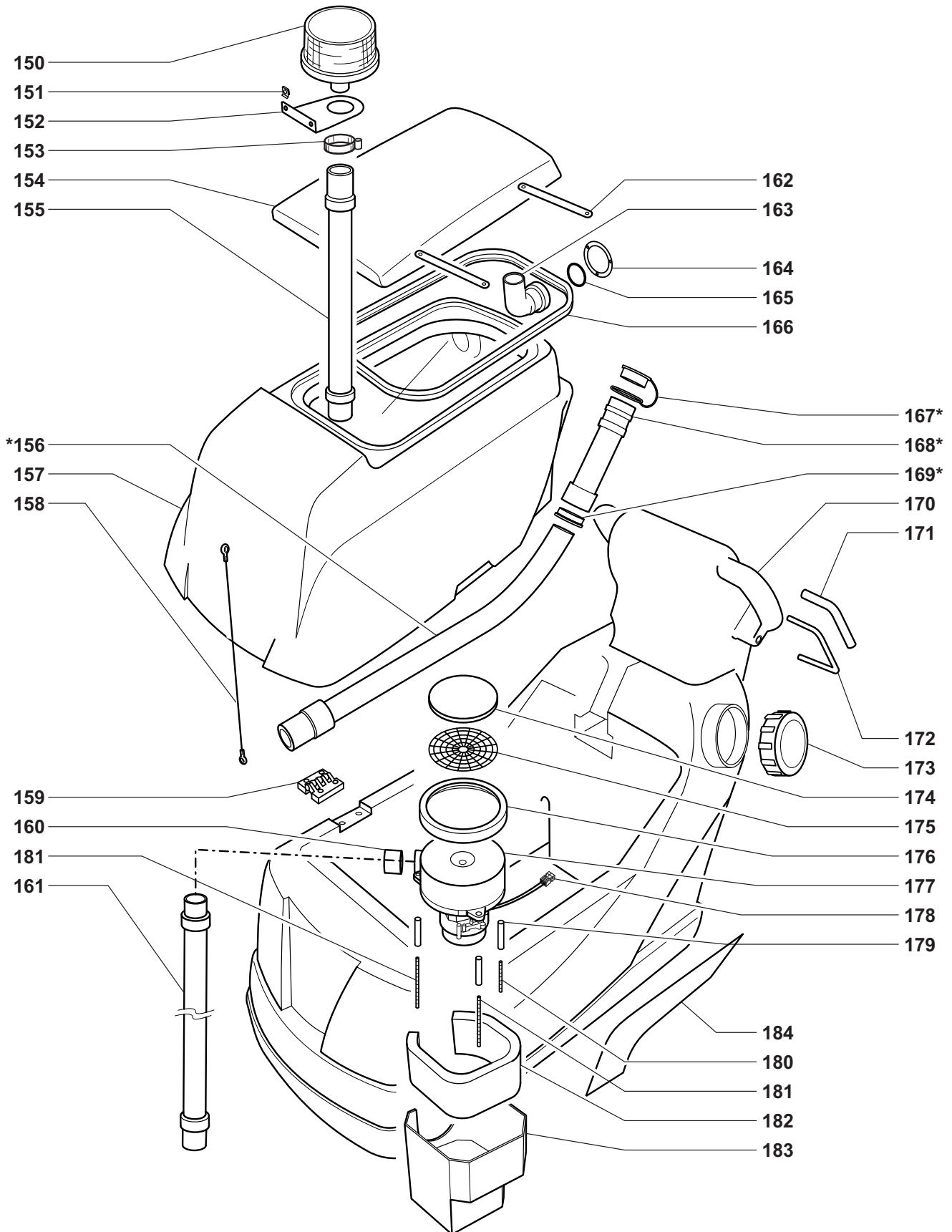

PFS24 TANKS and VACUUM MOTOR

No.	Part No.	Qty	Description
150	PFS0046	1	Vacuum Filter
151	PFS0047	1	Spring Clip
152	PFS0048	1	Support
153	PAS2072	1	Hose Clamp
154	PFS0049	1	Recovery Tank Lid
155	PFS0050	1	Stand Pipe
156	PFS0051	1	Complete Drain Hose 156 & 169
157	PFS0052	1	Recovery Tank
158	PFS0032	1	Cable
159	PFS0053	1	Hinge
160	PAS330	1	Vacuum Hose Coupler
161	PFS0054	1	Hose
162	PFS0055	1	Recovery Tank Strap
163	PAS2073	1	Elbow
164	PFS0056	1	Gasket
165	PFS0057	1	Seal
166	PFS0058	1	Seal
167	PFS0059	1	Plug
168	PFS0060	1	Hose
169	PFS0051	1	Complete Drain Hose 156 & 169
170	PFS0061	1	Solution Tank
171	PFS0062	2	Rubber
172	PFS0063	2	Lever
173	PFS0064	1	Solution Tank Cap
174	PFS0065	1	Filter
175	PAS79	1	Screen
176	PAS102	1	Motor Gasket
177	PFS0031	1	Vacuum Motor
178	PFS0015	1	Connection
179	PFS0066	3	Spacer
180	PAS2046	3	Tie Rod
181	PFS0067	2	Tie Rod
182	PFS0068	1	Sponge
183	PFS0069	1	Vacuum Motor Housing

PFS24 SQUEEGEE and BODY WORK

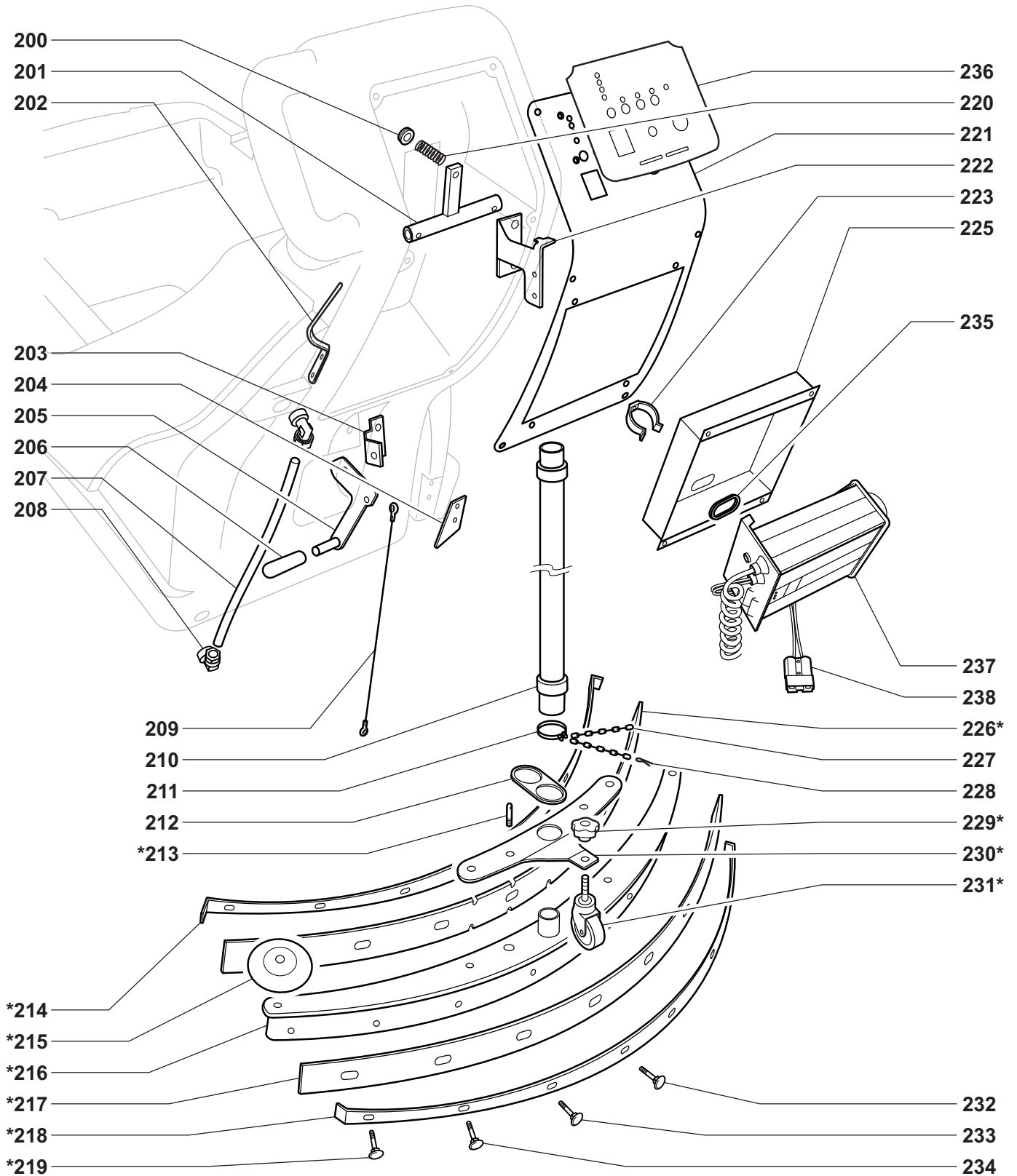

PFS24 SQUEEGEE and BODY WORK

No.	Part No.	Qty	Description
200	PFS0070	1	Gromet
201	PFS0071	1	Lever
202	PFS0072	1	Support
203	PFS0073	1	Support
204	PAS2063	1	Foot Pedal Catch
205	PFS0074	1	Lever
206	PFS0075	1	Handle
207	PFS0076	1	Hose
208	PFS0077	2	Hose Fitting
209	PFS0032	1	Cable
210	PFS0078	1	Squeegee Hose
211	PAS2075	1	Hose Clamp
212	PAS2078	1	Hose Guide
213	PAS2077	2	Pin
214	PAS2066	1	Front Retainer Strip
215	PAS1	1	Bumper Wheel
216	PFS0079	1	Squeegee Body
217	PFS0080	1	Rear Squeegee Rubber
217	PAS2004	1	Rear Squeegee Rubber
218	PAS2079	1	Rear Retainer Strip
219	PFS0081	2	Screw M6 x 50
220	PFS0082	1	Spring
221	PFS0083	1	Panel
222	PFS0084	1	Support
223	PAS2069	1	Hose Clip
225	PFS0100	1	Support
226	PFS0085	1	Front Squeegee Rubber
226	PAS2003	1	Front Squeegee Rubber
227	PAS41	1	Chain and Split Pins
229	701.292	1	Knob
230	PFS0086	1	Support
231	701.291	1	Caster Wheel
232	PFS0087	2	Screw M6 x 70
233	PFS0088	2	Screw M6 x 65
234	PFS0089	2	Screw M6 x 60
235	PFS0097	1	Gasket
236	PFS0098	1	Panel Decal PFS20
236	PFS0099	1	Panel Decal PFS24
237	PFS0096	1	Battery Charger
238	PAS59R	2	Connector (SB50 Red)
	PAS610	1	Complete Squeegee Assembly

PFS24 ELECTRICAL

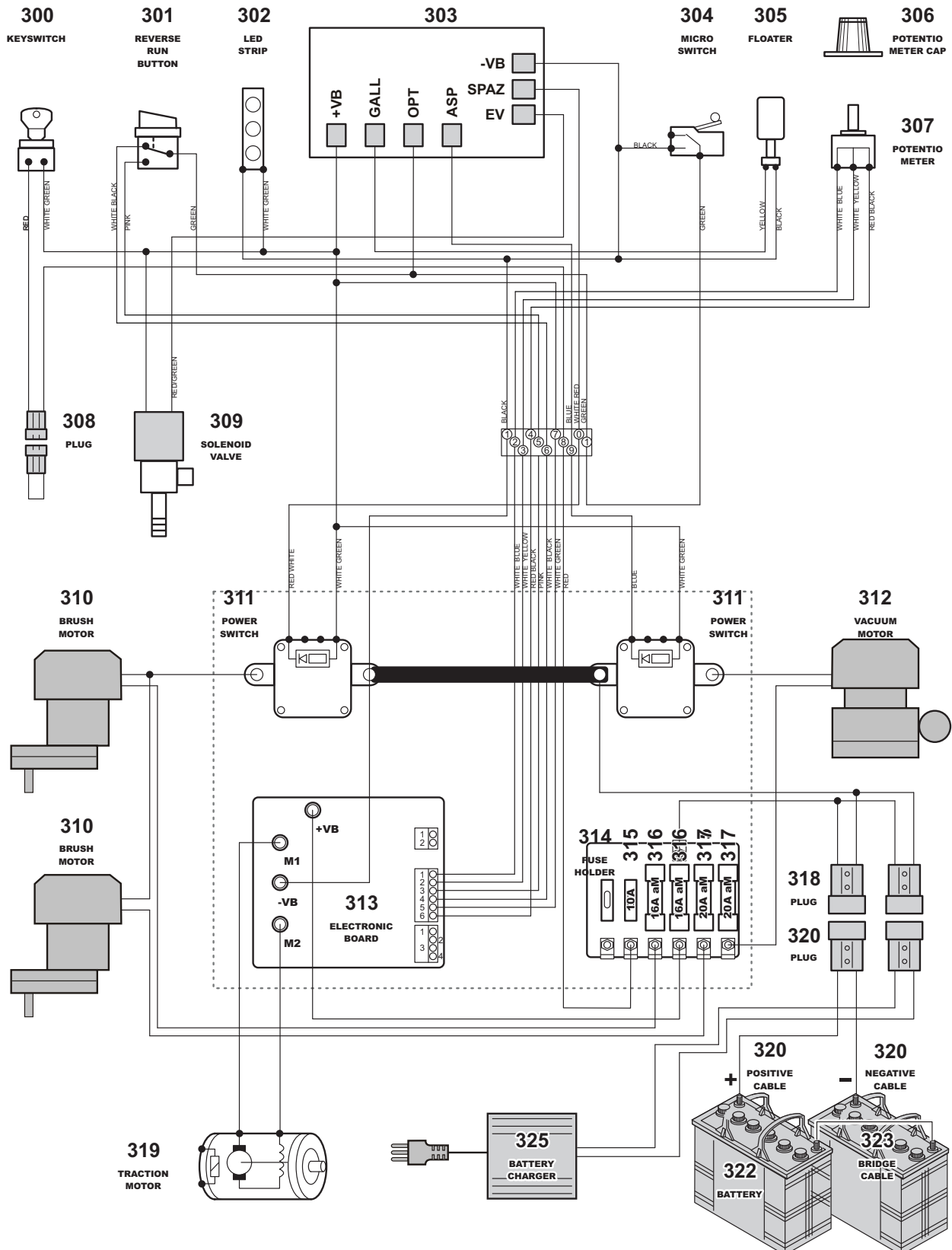

PFS24 ELECTRICAL

No.	Part No.	Qty	Description
300	PAS53NS	1	Key Switch
301	PAS295	1	Reverse Button
302	PFS0090	1	LED Strip
303	PFS0091	1	Electronic Card
304	PAS56	1	Drive Micro Switch
305	PFS0092	1	Float
306	PFS0093	1	Knob
307	PAS55	1	Potentiometer
308	PFS0015	2	Connector
309	PAS2035	1	Solenoid Valve
310	PAS4	1	Brush Motor 20" MACHINE
310	PFS0033	2	Brush Motor 24" MACHINE
311	PAS57	2	Power Switch
312	PFS0031	1	Vacuum Motor
313	PAS294A	1	Electronic Control Board
314	PFS0094	4	Fuse Holder
315	PFS0095	1	Fuse 10A
316	PAS117	2	Fuse 16A
317	PAS118	2	Fuse 20A
318	PAS59R	1	Connector
319	PFS0007	1	Complete Transaxle
320	PAS140	1	Connector w/ Battery Cables
322	B27TMX	2	Wet Lead-Acid Battery 12V 105 Ah
322	TBD	2	GEL Battery 12V 140Ah
323	PAS141	1	Jumper Cable
324	520.324	1	Complete Wiring
325	PFS0096	1	Battery Charger

For warranty information go to www.Powr-Flite.com

Powr-Flite[®]

A Tacony Company

3101 Wichita Court • Fort Worth, TX 76140-1755

1-800-880-2913 • Fax: 1-817-551-0719