

Powr-Flite[®]

OPERATOR'S MANUAL & PARTS LIST

Predator Automatic Scrubber 16 Model PAS16



**WARNING: OPERATOR MUST READ AND UNDERSTAND THIS MANUAL
COMPLETELY BEFORE OPERATING THIS EQUIPMENT.**

Save These Instructions

POWR-FLITE PREDATOR AUTOMATIC SCRUBBER 16

This manual refers to a cord electric automatic floor scrubber. Designed to be simple, easy to operate and safe, with maneuverability. Routine maintenance has been simplified and reduced to the minimum to keep equipment on the job.

The objective of this manual is to ensure that the machine is operated correctly and performs the service which we offer to our customers. Therefore, we advise **you to follow the instructions it contains scrupulously** since the manufacturer accepts no responsibility for damage to persons, or things, or damage to the machine if the machine is not operated the way described in this manual or if the maintenance and safety instructions are not fully complied with.

The instructions provided in this manual do not replace the safety instructions and technical data for installation and operation directly applied on the product, nor do they replace the safety standards current in the country of installation and the rules dictated by normal common sense.

The operator or maintenance worker must advise a person in authority of any faults or deterioration which could affect the original safety of the machine.

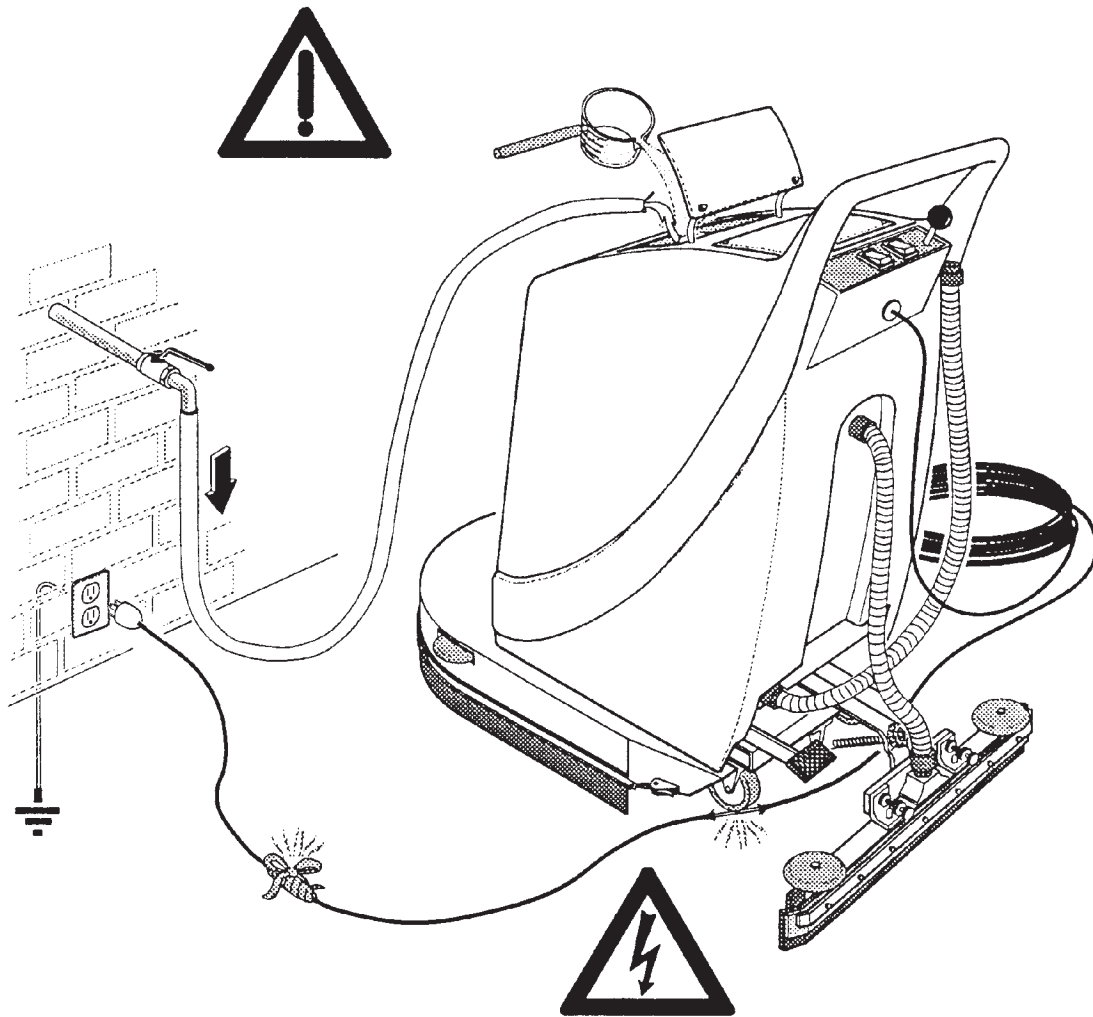

WARNING:

DO NOT OPERATE MACHINE IN AREAS WHERE FLAMMABLE LIQUIDS OR GASES ARE PRESENT.

DO NOT USE OR PICK UP FLAMMABLE CHEMICALS OR LIQUIDS WITH THIS MACHINE.

IMPORTANT SAFETY INSTRUCTIONS

All operators must read, understand and practice the following safety instructions. They will be repeated occasionally throughout this manual, and additional warnings may be added for specific cases.

Powr-Flite Predator 16 Electric Auto Scrubber

Your new Powr-Flite® Electric Auto Scrubber will afford you many years of trouble-free operating satisfaction provided it is given proper care. Prior to packaging, your Powr-Flite® Auto Scrubber was inspected by a Quality Control Technician.

UNCRATING

Your Powr-Flite® Electric Auto Scrubber was protectively packed to prevent damage in shipment. We suggest that upon removing the unit from its carton, you carefully inspect it for any possible damage in transit. If damage is discovered, immediately notify the transportation company who delivered your machine. As a manufacturer, we are unable to act upon any claim for concealed damage; you must originate the claim.

IMPORTANT SAFEGUARDS: This machine is designed to be safe when used to perform the functions specified in the Operator's Manual. Should damage occur to electrical or mechanical parts, the machine should be repaired by the manufacturer or competent service station before using in order to avoid further damage to the machine or physical injury to user.

WARNING: You must have training in the operations of this machine before using it. READ THIS OPERATOR'S MANUAL.

WARNING: Machines can burn flammable materials and vapors. Do not use this machine with or near fuels, or to pick up grain dust, solvents, thinners, or other flammable materials or liquids.

WARNING: Do not operate this machine unless it is completely assembled.

WARNING: Do not use this machine as a step or to move furniture.

WARNING: When disconnecting power cord from electrical outlet, grasp the plug. Pulling it out by the cord itself can damage cord insulation and internal connection to plug. To prevent electric shock, always remove the electrical plug from the electrical outlet before doing any repairs or maintenance to this machine.

WARNING: To prevent injury, always remove the electrical plug from the electrical outlet before changing the pad or brush and before leaving the machine.

WARNING: To prevent injury, keep hands, feet and loose clothing away from the rotating pad.

WARNING: Maintenance and repairs must be done by authorized personnel only.

WARNING: Never attempt to make emergency repairs or use non-original replacement parts.

WARNING: DO NOT RUN OVER POWER CORD.

WARNING: Never leave the machine unattended, particularly when there are children present.

WARNING: Keep all fasteners tight. Keep adjustments according to specifications.

WARNING: Always use a three-wire electrical system connected to the electrical ground. For maximum protection against electric shock, use a circuit that is protected by a ground fault circuit interrupter. Consult with your electrical contractor.

WARNING: To prevent damage to the power cord, do not let the pad, pad driver, wheels or squeegee touch the power cord when the machine is running. Always lift the power cord over the machine.

WARNING: Make sure all labels, decals, warning, cautions and instructions are fastened to the machine.

WARNING: Operators must read and understand this manual completely before operating this equipment.

WARNING: Loose objects on the floor can become dangerous projectiles if struck by the high-speed pad. Remove them before operating this machine.

WARNING: Keep machine moving to prevent damage to finish or floor.

WARNING: Do not operate this equipment in bare feet or with open-toed shoes or sandals.

WARNING: Store or park this machine on a level surface only.

WARNING: These machines are designed for level floor operations only. DO NOT OPERATE on ramps or inclines unless adequate personnel are available for assistance.

WARNING: Keep the electrical parts of this machine dry. Do not expose electrical components to water or other liquids. To clean machine wipe down with a damp cloth. Store machine in a building.

TECHNICAL CHARACTERISTICS

POWR-FLITE® PREDATOR™ 16 AUTO SCRUBBER MODEL PAS16

Technical Specifications	U.S. Standard	Metric
Area per hour	15,000 sq. feet	1425 sq. meters
Solution Tank	5.75 gallons	22 liters
Recovery Tank	5.75 gallons	22 liters
Cleaning Width (brush)	16 inches	400 mm
Squeegee Width	26.5 inches	680 mm
Brush Pressure	50 lbs.	22 kg
Brush Speed (operating)	290 RPM	
Brushes	16 inches	400 mm
Brush Motor (power rating)	1.0 H.P., 115 volt, 750 watts, 12.6 amp max	
Vacuum Motor (power rating) (U.L. Listed)	1.25 H.P., 115 volt, 1000 watts, 8.0 amp max	
Vacuum Water Lift	88 inches	
Power Cord (U.L. Listed)	75 feet, 14/3, STW/A	23 meters
Wheels/Casters	2 Fixed, 2 Casters, Non-Mar Polyurethane	
Dimensions - Scrubber	39"L x 18"W x 36"H	95 cm L x 46 cm W x 90 cm H
Weight	110 lbs.	50 kg

THE BASIC DESCRIPTION OF THE MACHINE CAN BE SUMMED UP BY THE FOLLOWING FEATURES:

- 1) Sealed ball-bearing wheels - maintenance free with non-mar polyurethane covered castors and wheels.
- 2) Unprecedented quality & workmanship, simplified control panel.
- 3) Hospital quiet, reduced noise level.
- 4) Bypass vacuum motor with easy access for filter and float cage service.
- 5) High-speed brush drive with 50 lbs. of contouring pad pressure prevents streaking and produces high productivity.
- 6) Solution control conveniently located with ease of operation and dispensing control...user friendly...
- 7) Increased working capacity and productivity offered by higher brush drive speed, increased full contouring pad pressure.
- 8) 15% fewer working parts and components for trouble free operating and servicing machine.
- 9) 10 year warranty on housing and tanks.
1 year warranty on brush and vacuum motors.
1 year warranty on parts and workmanship.
- 10) Rotationally molded design for housing, skirt and tank provide lighter weight, chemical resistance and styling features.
- 11) Design prevents solution contamination with servicable access to the solution and recovery tanks, vacuum motor.
- 12) Nylon squeegee body with reversible natural rubber squeegees.
- 13) Easy "Safe" access to the drive brush for pad or brush removal without requiring tilting of the unit to rear.
- 14) Squeegee design provides smooth follow operation when cleaning along walls and making runs.
- 15) Formed one piece zinc-plated frame.
- 16) Aluminum brush housing with baked enamel finish.
- 17) Vinyl splash skirt will not corrode.
- 18) Rear mounted quick release drain hose.
- 19) Compact and highly maneuverable.
- 20) Go anywhere portable convenience.

GENERAL OPERATION

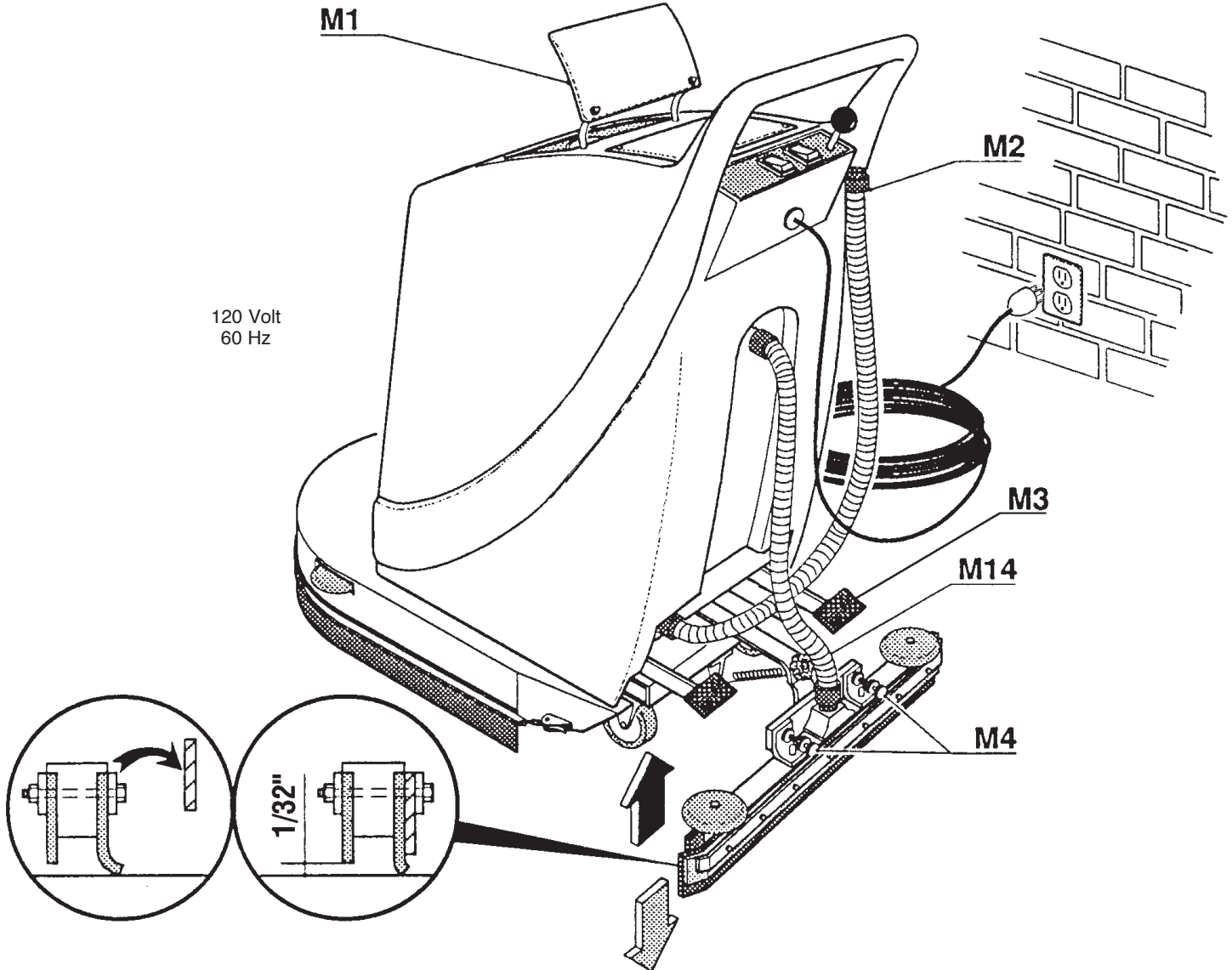

Solution Tank: The solution tank is located under the lid, at the front of the machine, with the filling-funnel **M1** in an accessible position for easy re-filling.

WARNING: Always switch off and unplug the machine before filling the solution tank.

Note: Always empty the dirty water collection tank, as described in the next paragraph, before refilling the tank with the diluted detergent solution. The solution tank has a maximum capacity of 5.75 gallons (22 liters). Always use the products and the dilution quantities recommended by the seller. Always use low foam detergents. Use defoamer if excess foam develops. Remove hose from vac intake and pick up defoamer directly into the recovery tank.

Water collection tank: The dirty water collection tank should be emptied, preferably each time after use, so that the dirt

does not settle there. To do this, remove the plug of the drain hose **M2**, which is kept in position by a simple spring clip, and empty dirty water into the proper drain conforming to local regulations.

Squeegee: The squeegee has the final task of completing the drying of the floor and it is very important for it to be in the correct position. Lower the squeegee to the working position by depressing pedal **M3** as shown. Adjust the position of the squeegee by means of the knobs **M4** so that the black rubber bar is about $\frac{1}{32}$ " (the thickness of a business card) from the floor. The squeegee behind this is in para rubber and must press on the floor with a certain amount of force. *After the first few hours the squeegee adjusts itself to the correct angle and drying becomes even better.* Squeegee pressure is adjusted by knob **M14**.

GENERAL OPERATION

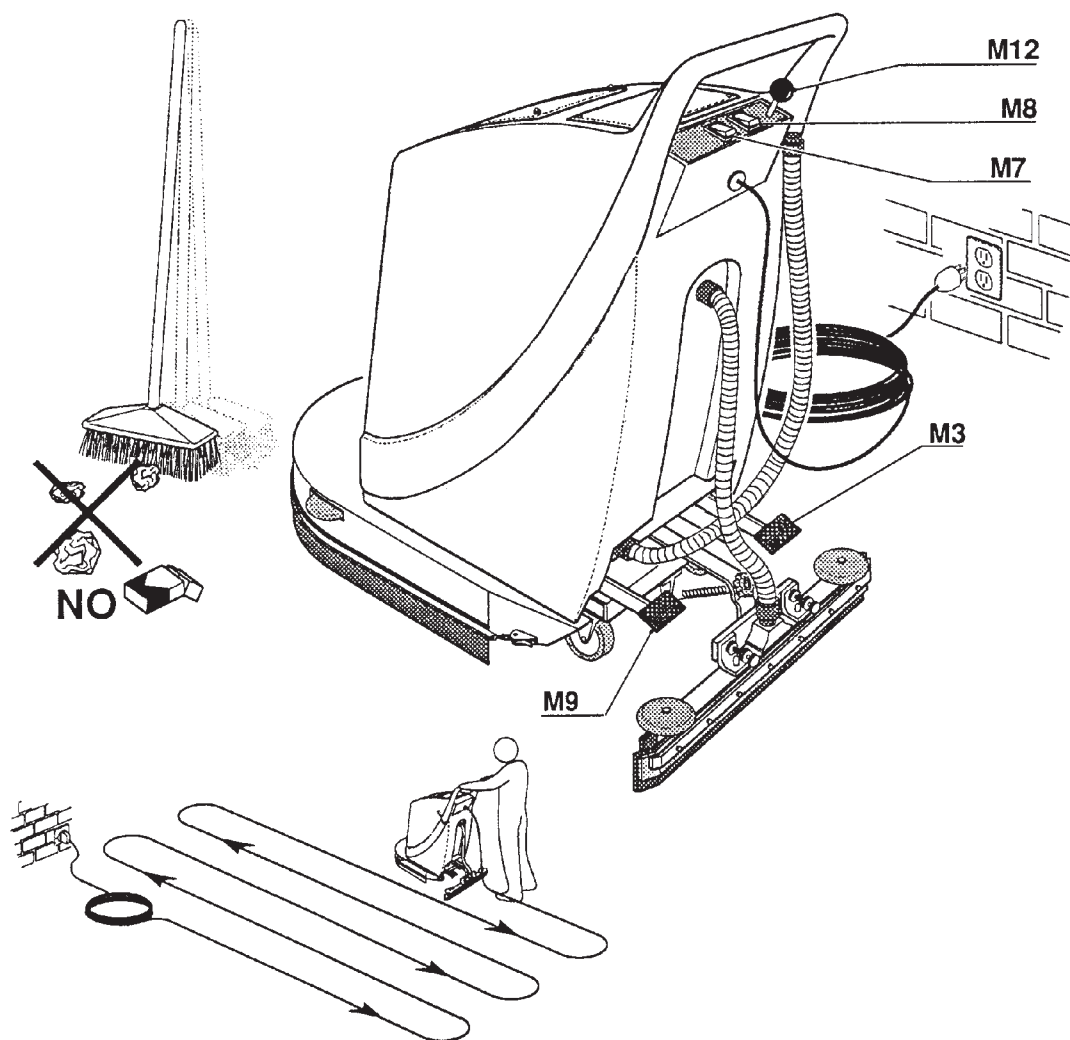

The area to be scrubbed: Debris and grit must be swept up before starting the scrubbing operation to avoid vacuum line blockage and to permit the detergent to perform efficiently.

Prior to startup and operation: *Caution:* **A)** Loose objects on the floor can become dangerous projectiles if struck by the high speed pad. Remove them before operating machine. **B)** Keep machine moving to prevent damage to finish or floor. **C)** These machines are designed for level floor operations only.

DO NOT OPERATE ON RAMPS OR INCLINES
unless adequate personnel are available for assistance.

Starting up and operation: Plug the machine into an outlet position allowing operation by moving away from the outlet.

NOTE: The PAS16 is intended for use with 120V/60Hz cycle grounded circuit. Extension cords are not recommended.

Then:

- Press switches **M7** and **M8**.
- Lower the brush by pressing pedal **M9**.
- Lower the squeegee by depressing pedal **M3**.
- Set the detergent solution supply to minimum by adjusting knob **M12**. Experience will help with the selection of the correct solution amount. Moving outward up and down as illustrated, allows cord to keep off of dirty floor and from dragging dirt into cleaned path.
- Finally, adjust the correct supply of detergent in proportion to the amount of dirt and amount of speed of advance by means of lever **M12**; this is a matter of experience. At this point the machine is ready to carry out the operations of scrubbing and drying at the same time.

Particularly dirty floors: Certain floors or areas may require special attention and, in some cases, cleaning twice. Go over the floor quickly the first time, with the squeegee raised and the brush in the working position. In this way, the detergent solution is left on the floor for a longer time and can dissolve the heavy dirt. The

GENERAL OPERATION

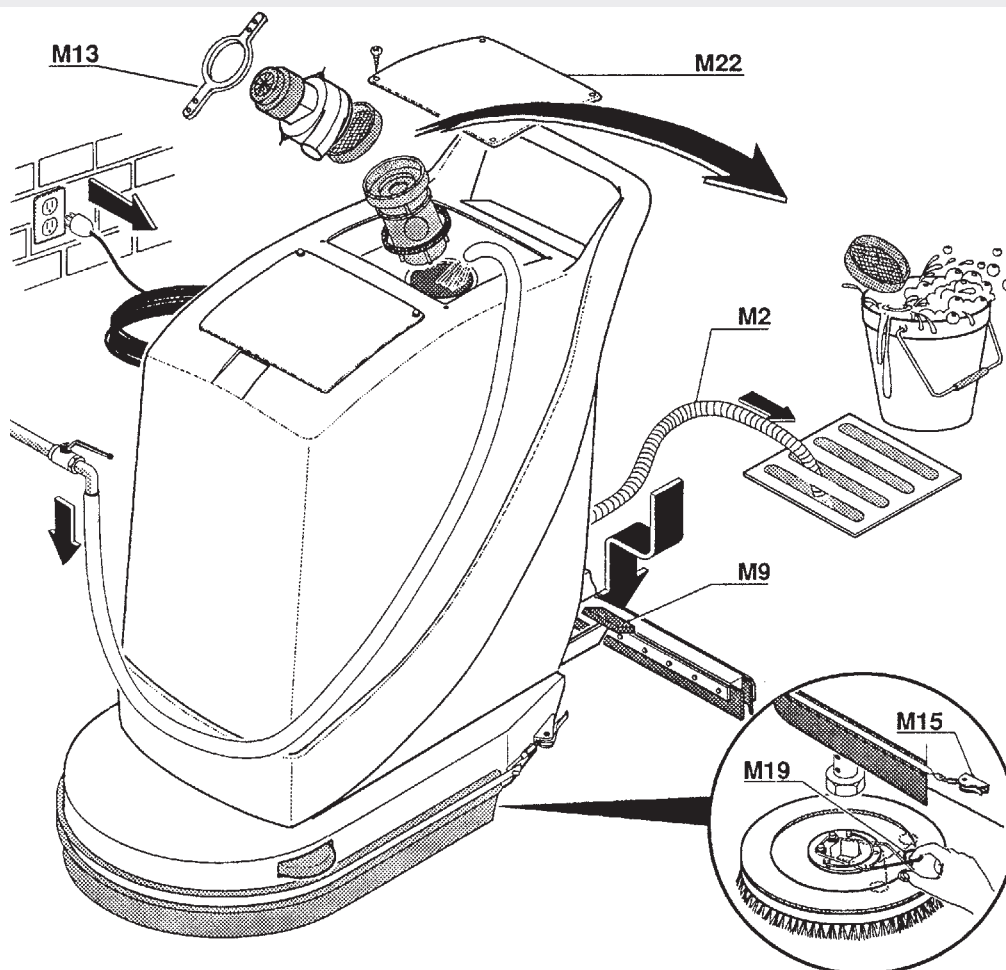

second time, go over the floor more slowly with both the brush and the squeegee lowered. Always apply and brush stripping solution without squeegee and vacuum then return to area after a minimum of 5 minutes and remove the suspended dirt, finish and solution.

Squeegee: Every week, check the blades of the squeegee and wash them carefully. Then replace them in the correct working position. If drying is not perfect even after the unit has been cleaned, replace any blades which are excessively worn. If the squeegee does not pick up enough water or streaks, lift and wipe off the blades.

The pad driver or brush must be in good working condition because it is the component which removes the dirt.

To remove the drive block, pad or brush:

- Fold the vinyl bumper over the left side of the brush housing.
- Depress the brush pedal (M9) with your right hand hold the brush position to allow free spinning by hand of the driver or brush until the scissors style spring lock can be squeezed with your left hand.

- Depress the brush pedal (M9) completely down clearing the brush or drive block and slide brush or driver out from under the housing.

To replace the drive block, pad or brush:

- Hold the brush pedal (M9) down while centering the brush or driver under coupling. While squeezing the spring lock together lower the coupling into the driver or brush center by allowing the brush pedal to raise. Release the scissors spring lock

The machine is supplied with a pad driver. Brushes in tynex, poly and steel are available on request, together with floor pads recommended for use with the pad driver. **Black** for stripping, **green** for deep scrub, **blue** for cleansing and red for light scrub.

Water collection tank: This tank should be cleaned every week. Lift the lid and remove the panel or funnel **M1** of the solution tank. Remove the strap **M13** and lift the vacuum motor out of its seat. Thoroughly clean the filter and wash out the dirt deposited in the tank with a jet of water, allowing it to drain out through hose **M2**. If necessary, replace filter. Replace float cage with open side facing front of scrubber.

PARTS LIST

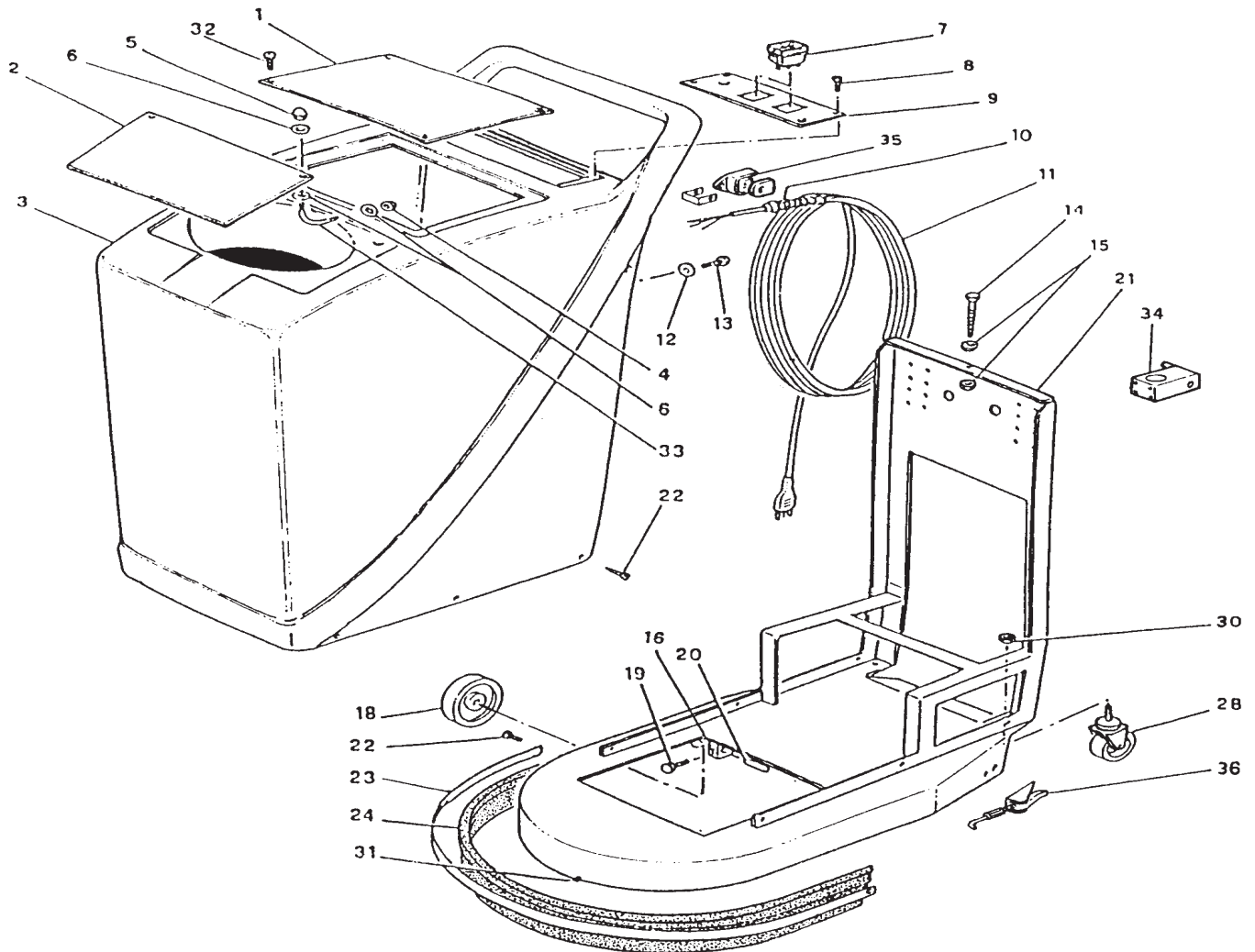

Pos	Part No.	Description	Pos	Part No.	Description	Pos	Part No.	Description
1	410.001	Cover	12	500.158	Washer	24	PAS128	Bumper
2	PAS260	Cover	13	410.013	Screw, Stainless	25	PAS18	Spring Handle
3	410.003	Housing	14	PAS197	Screw 6mm	26	PAS32	Tie Rod
4	PAS311	Cover Nut	15	PAS311	Cover Nut 6mm	28	PAS127	Caster
5	PAS304	Nut	16	410.016	Support	30	PAS311	Nut 6mm
6	PAS312	Cover Washer	18	PAS126	Wheel	31	PAS250	Housing Brush
7	PAS125	Switch	19	400.050	Screw 6mm	32	410.032	Screw, Stainless
8	PAS153	Screw, Stainless	20	400.049	Pin	33	PAS303	Hinge
9	PAS306	Control Panel	21	410.021	Panel	34	400.146	Block
10	PAS245	Strain Relief	22	410.022	Screw	35	PAS267	Cable Swivel
11	M1400	14/3 - 75' Cord	23	PAS211	Strap	36	PAS122	Hook & Latch Assy.

PARTS LIST

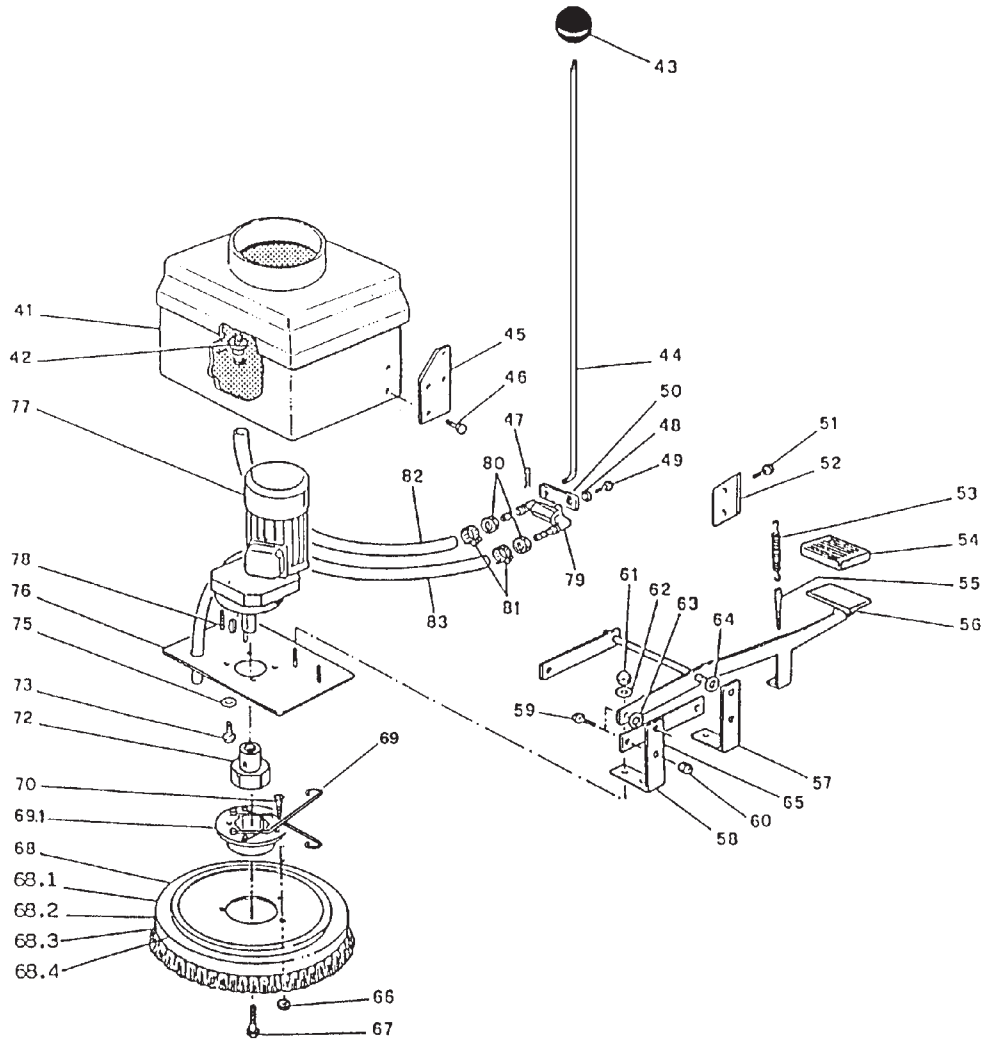

Pos	Part No.	Description	Pos	Part No.	Description	Pos	Part No.	Description
41	PAS314	Solution Tank	58	410.058	Bracket	71	430.072	Screw
42	PAS3	Screen	59	PAS167	Screw 8mm	72	PAS5	Coupling Half
43	PAS11	Knob	60	430.117	Nut 8mm	73	430.072	Screw
44	410.044	Rod	61	430.117	Nut 8mm	74	430.071	Washer
45	410.045	Plate	62	PAS188	Washer	75	PAS65	Washer
46	PAS147	Screw 6mm	63	410.063	Washer	76	410.076	Plate
47	500.056	Split Pin	64	410.064	Washer	77	PAS305-2	Geared Motor 220v
48	500.062	Washer	65	410.065	Support		PAS305	Geared Motor 110v
49	500.054	Screw 5/32"	66	PAS311	Nut 6mm	78	PAS167	Screw 8mm
50	500.051	Lever	67	PAS167	Screw 8mm	79	500.048	Valve
51	431.065	Screw 6mm	68	PAS97	Poly Scrub Brush	80	400.161	Nut 3/8"
52	PAS258	Bracket	68.1	PAS99	Powr-Nylon Brush	81	PAS42	Hose Clamp
53	410.053	Spring	68.2	PAS131	Strata Grit Brush	82	PAS288	Hose
54	PAS14	Foot Pedal Cover	68.3	PAS134	Powr-Scuff Brush	83	PAS288	Hose
55	PAS63	Pin/Tie Rod	68.4	PAS98	Powr-Scrub II			
56	410.056	Lever	69.1	PAS6A	Support with Spring			check for #99 bolt look on pas28
57	410.057	Bracket	70	PAS65	Screw			

PARTS LIST

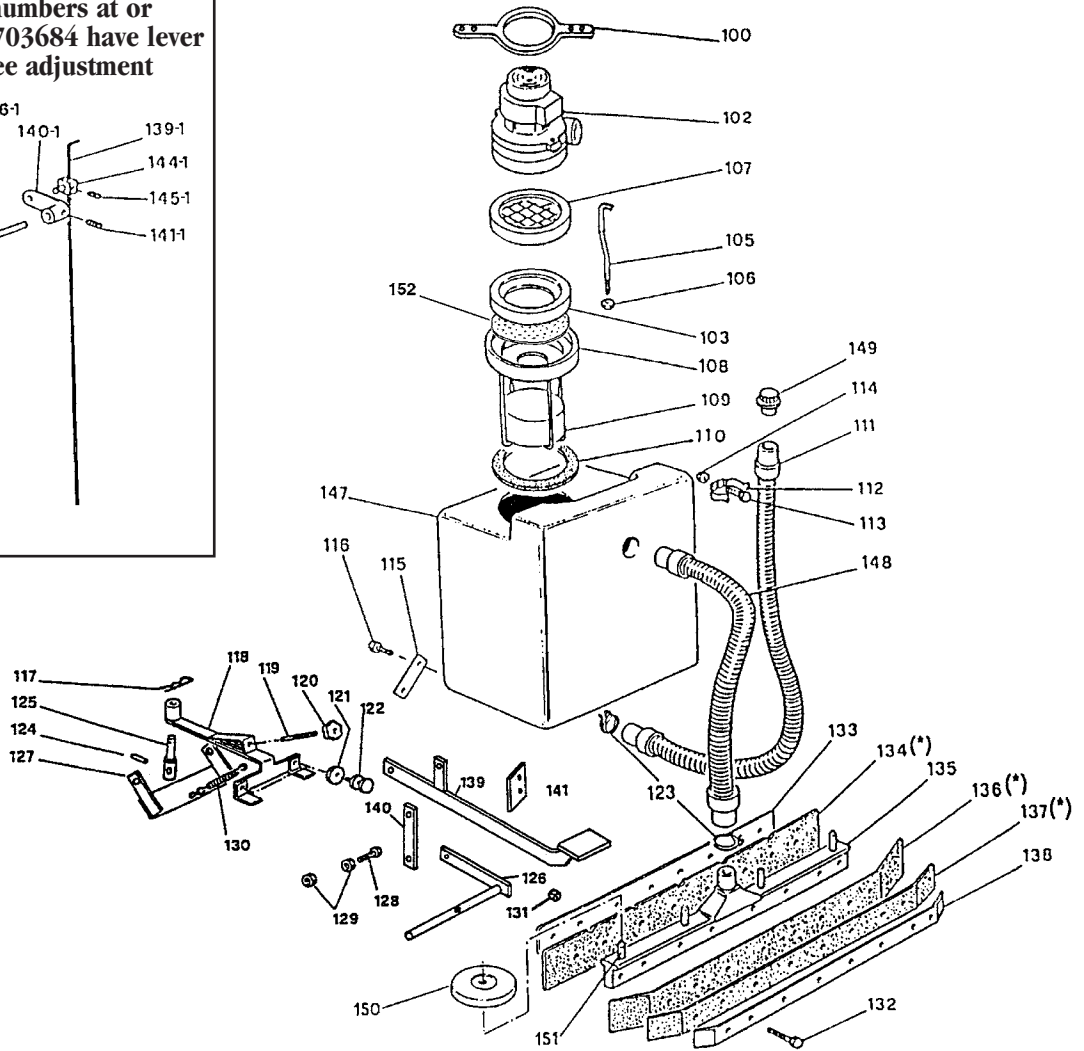
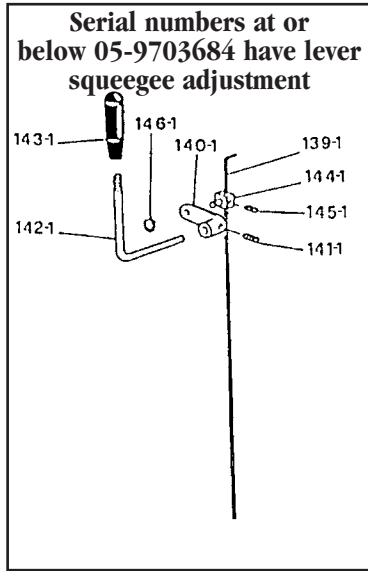

Pos	Part No.	Description	Pos	Part No.	Description	Pos	Part No.	Description
100	PAS15	Strap	124	500.157	Pin	142.1	410.142	Lever
102	1973	Vac Motor	125	PAS19	Pin Squeegee Mt.	143.1	400.127	Knob
103	PAS102	Gasket Motor	126	400.129	Shaft	144.1	400.148	Pivot Block
105	PAS198	Tie Rod	127	PAS264	Support	145.1	430.156	Dowel
106	PAS311	Nut M6	128	PAS936	Screw	146.1	430.159	Seeger, Clamp
107	F909	Filter/Screen	129	PAS935	Nut 10mm	147	PAS26	Tank
108	PAS85	Float Cage	130	PAS31	Spring	148	PAS37	Intake Hose
109	PAS210	Float	131	PAS304	Nut 6mm	149	PAS36	Plug
110	PAS103	Seal	132	PAS197	Washer 6mm	150	PAS51	Wheel, Bumper
111	PAS37	Drain Hose	133	430.198	Outer Bar	151	PAS193	Support Stud
112	PAS38	Hose Clamp	134	PAS 302	Black Rubber	152	F940	Foam Filter
113	430.194	Washer	135	PAS300R	Squeegee Body			
114	430.192	Nut M4	136	PAS 300	Main Squeegee Blade			
115	410.115	Plate	137	PAS240	Squeegee Complete			
116	PAS147	Srew	(*)	PAS 124	Squeegee Blade Set			
117	PAS266	Split Pin	138	430.204	Outer Bar			
118	PAS315	Bracket	139	410.139	Pedal			
119	PAS32	Tie Rod	139.1	PAS129	Cable			
120	PAS35	Knob M6	140	410.140.1	Connecting Rod			
121	PAS33	Ring-nut	140.1	410.140	Connecting Rod			
122	PAS34	Adjusting Screw	141	PAS259	Cross Member			
123	PAS191	Clamp, Hose	141-1	PAS313	Dowel M8			

ELECTRICAL DIAGRAM

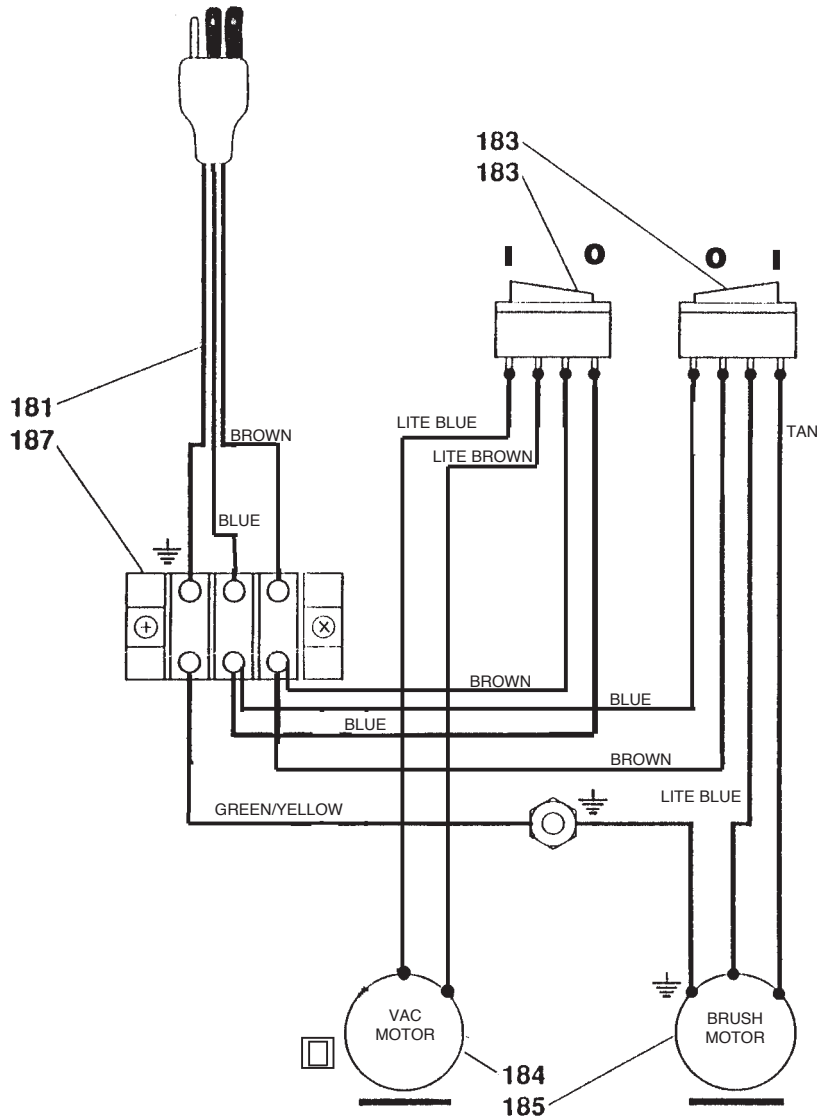

Pos	Part No.	Description	Pos	Part No.	Description	Pos	Part No.	Description
181	M1400	14/3, 75' Cord	184	1972	Suction Motor	187	PAS309	Connecting Board
183	PAS125	Switch	185	430066E	Brush Motor			

Powr-Flite[®]

A Tacony Company

3101 Wichita Court • Ft. Worth, TX 76140-1755

1-800-880-2913 • Fax: 1-817-551-0719 • www.Powr-Flite.com