

# **Powr-Flite**<sup>®</sup>

**COMMERCIAL FLOOR CARE EQUIPMENT**

## **Model PF600BP-PF1000BP Backpack Vacuum**

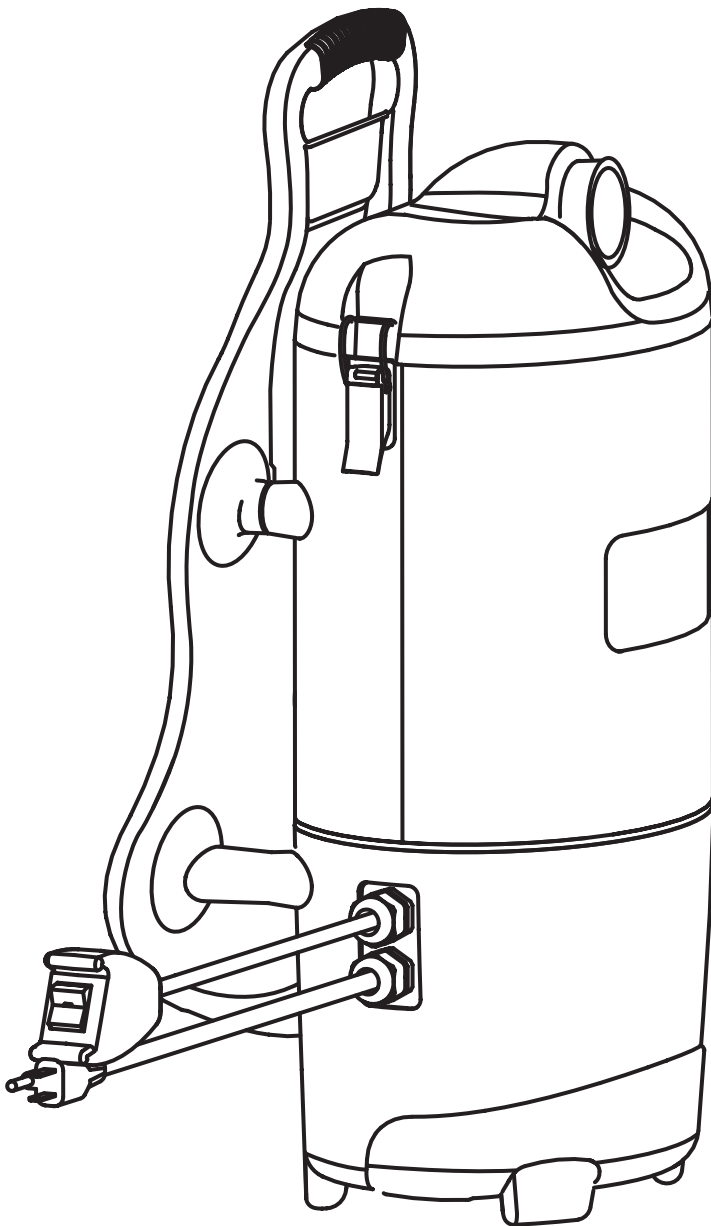

### **OPERATING INSTRUCTIONS**

COMMERCIAL AND HOUSEHOLD  
BACKPACK VACUUM CLEANERS

#### **CONGRATULATIONS**

YOU HAVE JUST ACQUIRED A HIGH QUALITY VACUUM  
CLEANER. PLEASE READ THIS MANUAL CAREFULLY,  
BEFORE OPERATING YOUR NEW VACUUM CLEANER.  
KEEP MANUAL ON HAND FOR FURTHER REFERENCES.

**Save These Instructions**

# Model PF600BP - PF1000BP Parts

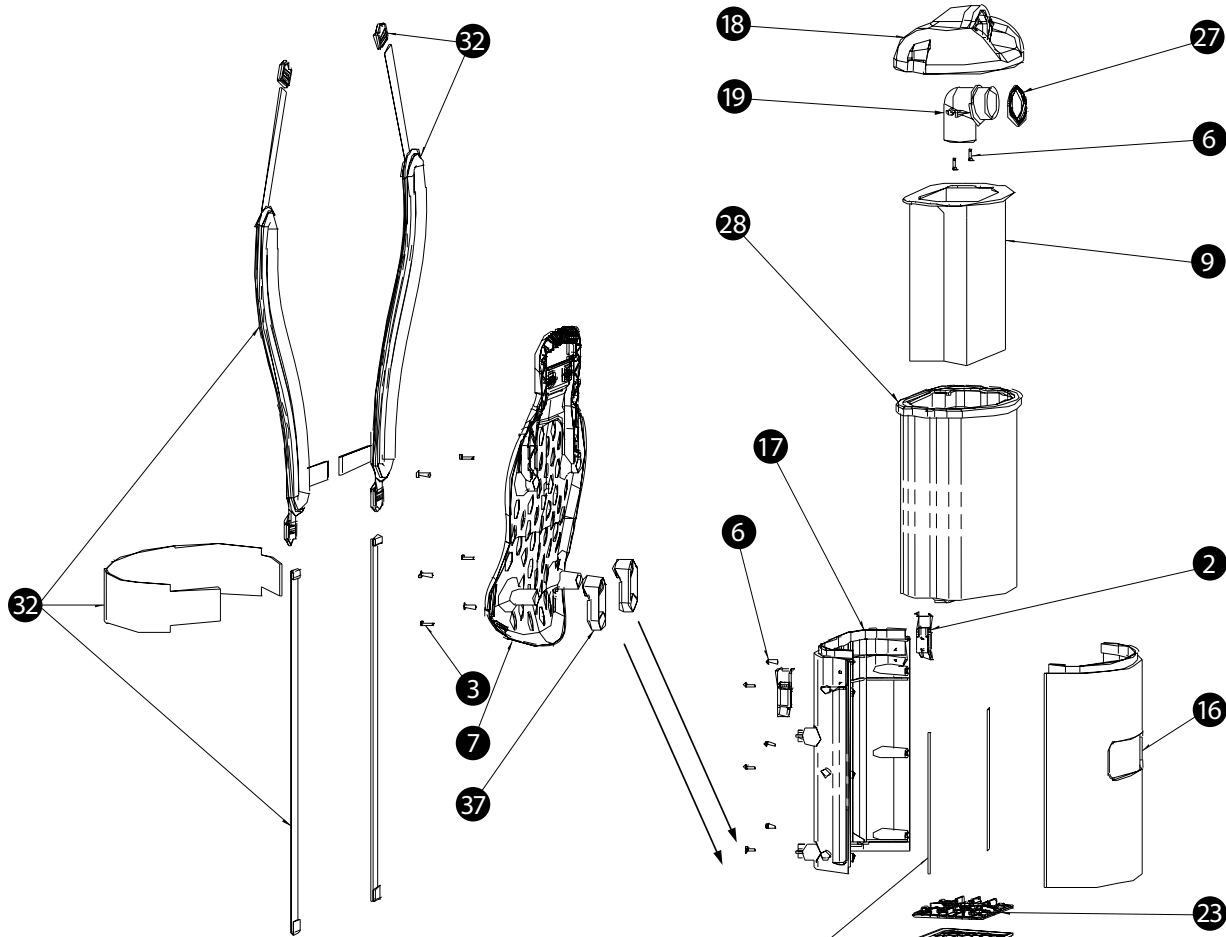

## Parts List for PF600BP

ref #	item #	description
1	A328-1400	THERMAL PROTECTION SWITCH
2	A352-3300	LATCH
3	A352-8100	#10 .750 TYPE B PHILIPS PAN HEAD SCREW
4	A352-8200	#6 X .375 HI-LO PHILIPS PAN HEAD SCREW
5	A430-0205	#8-16 X 2.500 PHILIPS PAN HEAD SCREW
6	A732-8300	#8 X .625 HI-LO PHILIPS PAN HEAD SCREW
7	C352-9200	BACK SET
8	B352-2400	POST FILTER
9	B325-2500	PAPER BAG
10	B352-3200	POWER HARNESS
11	B352-6100	BAG COMPARTMENT SEAL
12	B352-600	HEYCO FITTING
13	B352-6800-NUT	HEYCO FITTING NUT
14	B352-0100	MOTOR COMPARTMENT
15	B352-0200	BUMPER
16	B352-0300	FRONT PLATE
17	B352-0400	BACK PLATE
18	B352-0500	COVER
19	B352-0600	HOSE INLET
20	B352-0700	MOTOR COVER
21	B352-0800	SECONDARY FILTER PLATE
22	B352-0900	SECONDARY FILTER FRAME
23	B352-1000	SECONDARY FILTER CAP
24	B352-8000	POST FILTER FRAME
25	B352-1200	BODY SEAL
26	B352-1900	BOTTOM MOTOR MOUNT
27	B352-4800	INLET SEAL
28	C352-1400	SHAKE OUT BAG
29	C352-2800	SWITCH HARNESS
30	A113-2600	5.1" SINGLE STAGE TEK MOTOR
31	B113-0915	TEK MOTOR SHROUD PC
32	X9811	SHOULDER HARNESS ASSEMBLY
33	B352-1800	TOP MOTOR MOUNT
34	B352-5300	MOTOR SHROUD BOTTOM 5.1 - 1 STAGE
35	B352-5400	MOTOR SHROUD TOP 5.1 - 1 STAGE
36	B352-5500	MOTOR SEAL

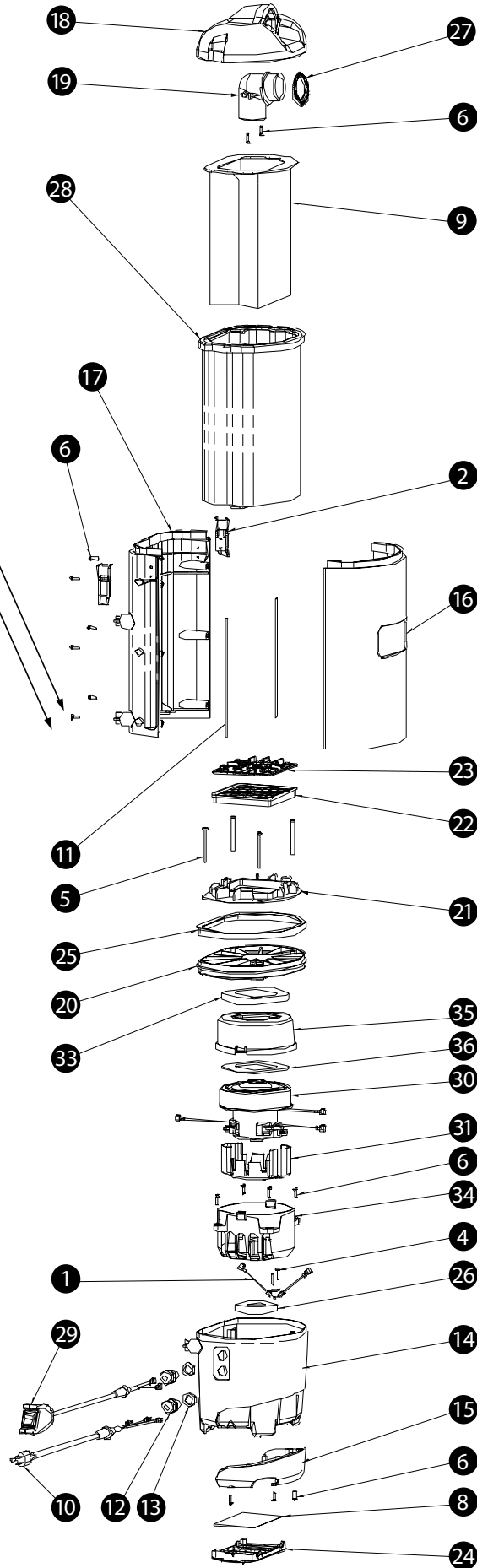

**Parts List for PF100BP**

ref #	item #	description
1	A328-1400	THERMAL PROTECTION SWITCH
2	A352-3300	LATCH
3	A352-8100	#10 .750 TYPE B PHILIPS PAN HEAD SCREW
4	A352-8200	#6 X .375 HI-LO PHILIPS PAN HEAD SCREW
5	A430-0205	#8-16 X 2.500 PHILIPS PAN HEAD SCREW
6	A732-8300	#8 X .625 HI-LO PHILIPS PAN HEAD SCREW
7	C352-9200	BACK SET
8	B352-2400	POST FILTER
9	B325-7800	PAPER BAG
10	B352-3200	POWER HARNESS
11	B352-6100	BAG COMPARTMENT SEAL
12	B352-600	HEYCO FITTING
13	B352-6800-NUT	HEYCO FITTING NUT
14	B352-0100	MOTOR COMPARTMENT
15	B352-0200	BUMPER
16	B352-7639	FRONT PLATE
17	B352-7743	BACK PLATE
18	B352-0500	COVER
19	B352-0600	HOSE INLET
20	B352-0700	MOTOR COVER
21	B352-0800	SECONDARY FILTER PLATE
22	B352-0900	SECONDARY FILTER FRAME
23	B352-1000	SECONDRAY FILTER CAP
24	B352-8000	POST FILTER FRAME
25	B352-1200	BODY SEAL
26	B352-1900	BOTTOM MOTOR MOUNT
27	B352-4800	INLET SEAL
28	C352-1500	SHAKE OUT BAG
29	C352-2800	SWITCH HARNESS
30	A113-2600	5.1" SINGLE STAGE TEK MOTOR
31	B113-0915	TEK MOTOR SHROUD PC
32	X9811	SHOULDER HARNESS ASSEMBLY
33	B352-1800	TOP MOTOR MOUNT
34	B352-5300	MOTOR SHROUD BOTTOM 5.1 - 1 STAGE
35	B352-5400	MOTOR SHROUD TOP 5.1 - 1 STAGE
36	B352-5500	MOTOR SEAL
37	B352-8100	BACKREST MOUNT

**Not Illustrated**

ref #	item #	description
1	A134-0441	50' EXTENSION CORD 16-3 SJT YELLOW
2	A352-3400	HOSE
3	B352-3500	UPHOLSTERY TOOL
4	B352-3600	CREVICE TOOL
5	B352-3700	DUST BRUSH TOOL BODY
6	B352-3800	DUST BRUSH BRISTLES
7	B352-3900	DOUBLE BEND WAND
8	B352-4200	CARPET TOOL BODY
9	B352-4300	CARPET TOOL BUMPER
10	B352-4500	BARE FLOOR TOOL BODY
11	B352-4600	BARE FLOOR TOOL BRUSH

***The Powr-Flite Limited Warranty***

The manufacturer warrants to the original purchaser that products manufactured are free from defects, provided such goods are installed, operated and maintained in accordance with written manuals or other instructions for a period of 1 year from date of purchase on workmanship, motor, and parts. In case you, as our customer, meet any trouble with your machine, contact a Powr-Flite representative, who will be happy to be of service to you and will take care of any warranty issues. This warranty covers normal use and does not cover damage which occurs in shipment or failure resulting from altercation, accident, misuse, abuse, neglect or improper maintenance.



*A Tacony Company*

3101 Wichita Court • Ft. Worth, TX 76140-1710 • Call 1-800-880-2913 • www.Powr-Flite.com