



**Models M171, M171HD, M171SD, M172, M173, M201, M201HD, M202, and M203 Polishers**

**FLOOR MACHINES**  
Parts for M-SERIES MACHINES

ref #	order	description	each
1	<b>M1369GS</b>	sub, 14/3 STWA, 50' gray,	
2	<b>SR36</b>	strain relief washer	
3	<b>X8008N</b>	nut, lock, 1/2" steel conduit	
6	<b>X8012</b>	clamp, collar, handle	
7	<b>X8013</b>	cord hook, plated	
8	<b>X8207</b>	screw, 10-24 x 1/2", phph, type "f"	
9	<b>X8012A</b>	handle clamp assembly	
10	<b>X8016</b>	knob, plastic, handle release	
11	<b>X8807R</b>	handle brace, right	
12	<b>X8807L</b>	handle brace, left	
13	<b>X8809</b>	pivot shaft, 1/2" x 12-7/8"	
14	<b>X8019</b>	axle wheel	
15	<b>X8020</b>	washer, countersunk, axle	
16	<b>X8024</b>	wheel 5" x 1 1/4"	
17	<b>X8028</b>	washer, cam, w/slot	
18	<b>X8035</b>	1-1/2 hp motor w/o gear unit M171HD, M171SD, M201HD, M203, M173	
	<b>X8909</b>	1-1/2 hp 175RPM motor with gear unit for M171HD, M171SD, M201HD	
	<b>X8035-3</b>	1-1/2 hp 300 RPM motor with gear unit, M173, M203	
	<b>X8045</b>	1 hp motor w/o gear unit M201, M171	
	<b>X8045-1</b>	1 hp 175 RPM motor with gear unit, M171, M201	
	<b>X8071</b>	2 speed 1-1/2 hp motor assembly for M202, M172	
18A	<b>X8072</b>	300 RPM gear unit, M173, M203	
	<b>X8073</b>	175 RPM gear unit, M171, M171HD, M201, M201HD	
19	<b>X8042A</b>	motor cover	
20	<b>X8052</b>	20" base housing	
21	<b>X8040</b>	590 MFD, 110V start capacitor for Doerr 1 hp 175 RPM motor	
22	<b>X9044</b>	start capacitor, 3 post, 1.5 hp 450 mh	
	<b>X8038</b>	220 volt run capacitor	
	<b>X8056</b>	310 MFD 125V start capacitor for 1 1/2 hp Doerr Model #R07559 & G51400	
23	<b>X8022B</b>	sub., cord, in-line 14/3 SJTWA 49"	
24	<b>X8030I</b>	bumper 38.25" blu/blk	
25	<b>X8151B</b>	plug, plastic, 7/16" hole, for base housing	
26	<b>X8258A</b>	bumper, blk, 1.13" od x .75" h	
27	<b>X8258AS</b>	#8 x 1" phph type A	
28	<b>X8278</b>	3-32 x 1/2" phph, black oxide	
29	<b>X8821</b>	screw, 8-32 x 3/4", thph, blk plated	
30	<b>X8822</b>	spacer, #8 x .25, plastic black	
31	<b>X8212</b>	1/4" spring lock washer	
32	<b>X8218</b>	washer, flat, SAE 5/16"	
33	<b>X8219</b>	3/8" SAE flat washer	
34	<b>X8222</b>	1/4-20 x 3/16" socket set	
35	<b>X8226</b>	1/4-20 x 1 1/4 hex head cap	
36	<b>X8272</b>	screw, 8-32 x 1/2", truss/ph,	
58	<b>X8912</b>	switch box cover	
59	<b>X8914</b>	thumb actuation release	
60	<b>X8917</b>	handle trigger	
61	<b>X8916</b>	trigger tension spring, 2	
62	<b>X8915</b>	handle trigger thumb actuation spring	
63	<b>X8918</b>	handle roller pin, 2	
64	<b>X8941</b>	handle grip, 2	
65	<b>X8207</b>	#10-24 screw, 3	
	<b>7CY001</b>	lock washer, 3	
66	<b>X8923</b>	insulation sheet	
67	<b>F5P</b>	switch	
69	<b>7BG004</b>	7/16" diameter grommet	
70	<b>X8222</b>	1/4-20 x 3/16" set screw	
71	<b>X8265</b>	screw 1/4-20 x 3/4 flat phil	

**NOT ILLUSTRATED**

	<b>PX7</b>	switch, M172, M202
	<b>PX28</b>	insulation boot for switch
	<b>X8575</b>	clutch plate screws
	<b>X8911</b>	all metal handle assembly
	<b>M8600-3</b>	handle retro kit, M series all metal
	<b>X8265</b>	bolt
	<b>X8530</b>	2 speed controler

**"M" series Pre 2003 handle parts**

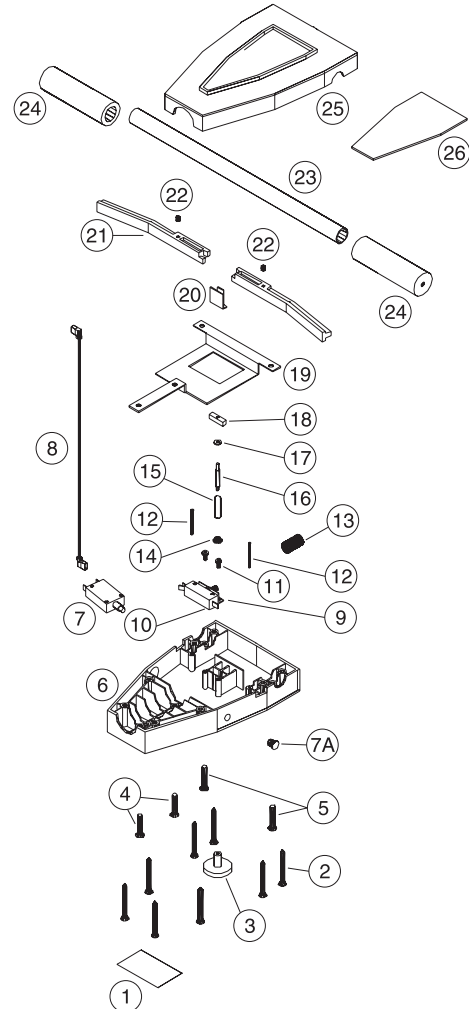

ref	order	description
	<b>M8600</b>	complete handle assembly
1	<b>X8418A</b>	warning label
2	<b>X8820</b>	12 x 2 phil flat ts-a
3	<b>X8805</b>	lock out knob
4	<b>X8819</b>	1/4 x 1-1/4 phil flat mach scr
5	<b>X8818</b>	1/4 x 1-1/2 phil flat tc-f
6	<b>X8002A</b>	bottom handle housing
7	<b>X8023A</b>	circuit breaker, 15a, w/nuts
7A	<b>X8151C</b>	3/8" hole plug
8	<b>X8009</b>	lead, 14g, blk, 4", w/2 f26
9	<b>X8006</b>	switch bracket
10	<b>F5P</b>	momentary switch 1901-012104
11	<b>X8284</b>	8-32 x 3/8" phph, type F
12	<b>X8026</b>	trigger pin
13	<b>X8010</b>	switch spring
14	<b>X8823</b>	lock-out bushing
15	<b>X8814</b>	spring, od .312, wire dia .025
16	<b>X8804</b>	lock-out rod
17	<b>X8817</b>	#6 SAE flat washer, black
18	<b>X8803</b>	lock out stop
19	<b>X8806</b>	plate, handle support
20	<b>X8061</b>	clip switch lever
21	<b>X8003</b>	handle switches trigger
22	<b>X8110A</b>	compression spring
23	<b>X8005</b>	cross bar handle
24	<b>X8007</b>	handle grip
25	<b>X8001A</b>	top handle housing
26	<b>X8815</b>	handle, back, M-series, w/label

Call Toll Free 800.880.2913

Visit Our Website at [www.powrflite.com](http://www.powrflite.com)