

Powr-Flite[®]

COMMERCIAL FLOOR CARE EQUIPMENT

WET/DRY VACUUM Models PF54

OPERATING INSTRUCTIONS

Equipment must be operated, serviced and maintained in accordance with the manufacturer's instructions.



Save These Instructions

SAVE THESE INSTRUCTIONS FOR FUTURE REFERENCE

*When using a wet/dry vacuum, basic precautions should be followed.

*Read all instructions before using your vacuum.

IMPORTANT SAFETY ADVICE

When using electrical equipment basic safety precautions should be followed including the following:

You must have training in the operation of this machine before using it. Read all instructions carefully before use.

- Keep children and unauthorized persons away from the machine when in use.
- Do not leave the machine plugged in when not in use.
- Switch the machine off before removing the plug from the outlet.
- When unplugging, pull the plug, not the cord.
- The machine must be unplugged prior to cleaning or servicing the machine .
- Keep the power cord clear of moving parts.
- Do not run the machine over the power cord.
- Do not operate the machine with a damaged power cord or plug, or if the machine malfunctions or is damaged in any way.
- Do not use where hazardous dust is present.
- Do not use in an explosive atmosphere.
- Do not use where flammable liquids or gasses are present.
- Do not use or pick up flammable chemicals or liquids with this machine.
- Take care when using the machine near the top of stairs to avoid overbalancing.
- Maintenance and repair must be done by authorized personnel only.
- Wear suitable footwear to avoid slipping.
- Do not operate this machine in bare feet or with open-toed shoes or sandals.
- Do not smoke when using the machine.
- CAUTION:-This machine is for indoor use only and should not be used or stored outdoors or in wet conditions.

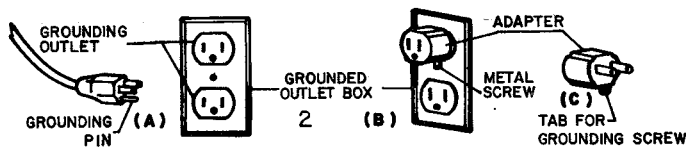

DRY OPERATION OF VACUUM

The wet/dry vacuums are equipped with bypass motors. Install the cloth filter, place the motor head on the canister and snap down the hold-down clamps.

WET OPERATION OF VACUUM

The wet/dry vacuums are equipped with a bypass motor so that the working vacuum is separated from the cooling air flow. To pick up water, the dry filters must be removed. The safety float assembly, located in the vacuum head, stops the vacuum motor when water in the tank exceeds the safety level.

WAND AND ATTACHMENT INSTRUCTIONS

To assemble the two piece wand:

1. Match the alignment ridges of the upper and lower wand sections.
2. Push the upper wand into the lower wand.

To assemble tools:

1. Slide the swivel cuff of the tool onto the tapered lower wand.
2. Turn swivel cuff 1/4 turn to tighten.



DRAINING

When the tank is full.

1. Release drain hose from hose clamp.
2. Remove plug from hose end to start draining process.
3. When draining is complete, replace hose plug and snap hose back into clips on side of tank.

NOTE: When the water level in the tank exceeds the safety level, the safety device will automatically block the inlet, and the motor turning sound will be changed, but power will remain ON. The power must be turned OFF before emptying the tank.

REMOVE THE PAPER FILTER

The paper filter must be removed for wet recovery.
Push the metal ring counterclockwise to release the filter.
Remove the paper filter.

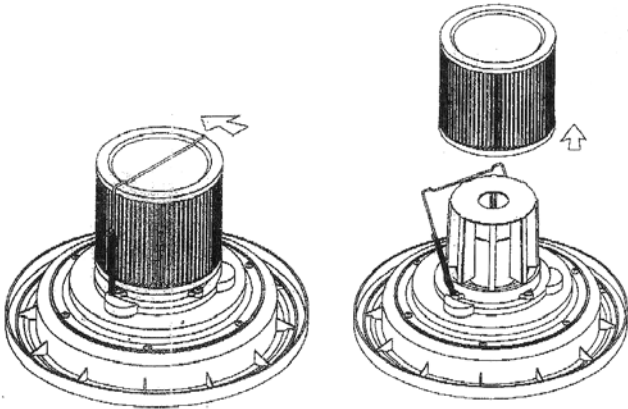

HOSE ATTACHMENT INSTRUCTIONS

The hose and swivel connector are pre-assembled at the factory.
To attach the swivel connector to the intake fitting of the canister:

1. Push the grooved cuff straight into the intake fitting.
2. To remove, press the release button on top of the intake fitting while pulling the grooved cuff out.

MAINTENANCE AND SERVICING

1. To dismantle, unclip both latches and remove top housing and filter with frame.
2. Wash the filter with water and allow it to dry.
3. After washing, remove excess water with a gentle squeegee.
4. Replace the filter and top housing and fasten the latches.

NOTE: This cleaner is designed with a powerful suction. Do not be alarmed if the motor noise increases when performing tougher cleaning work.



Model PF54 drain hose.



Model PF54 shown with optional front mounted squeegee.

Model PF54 Parts

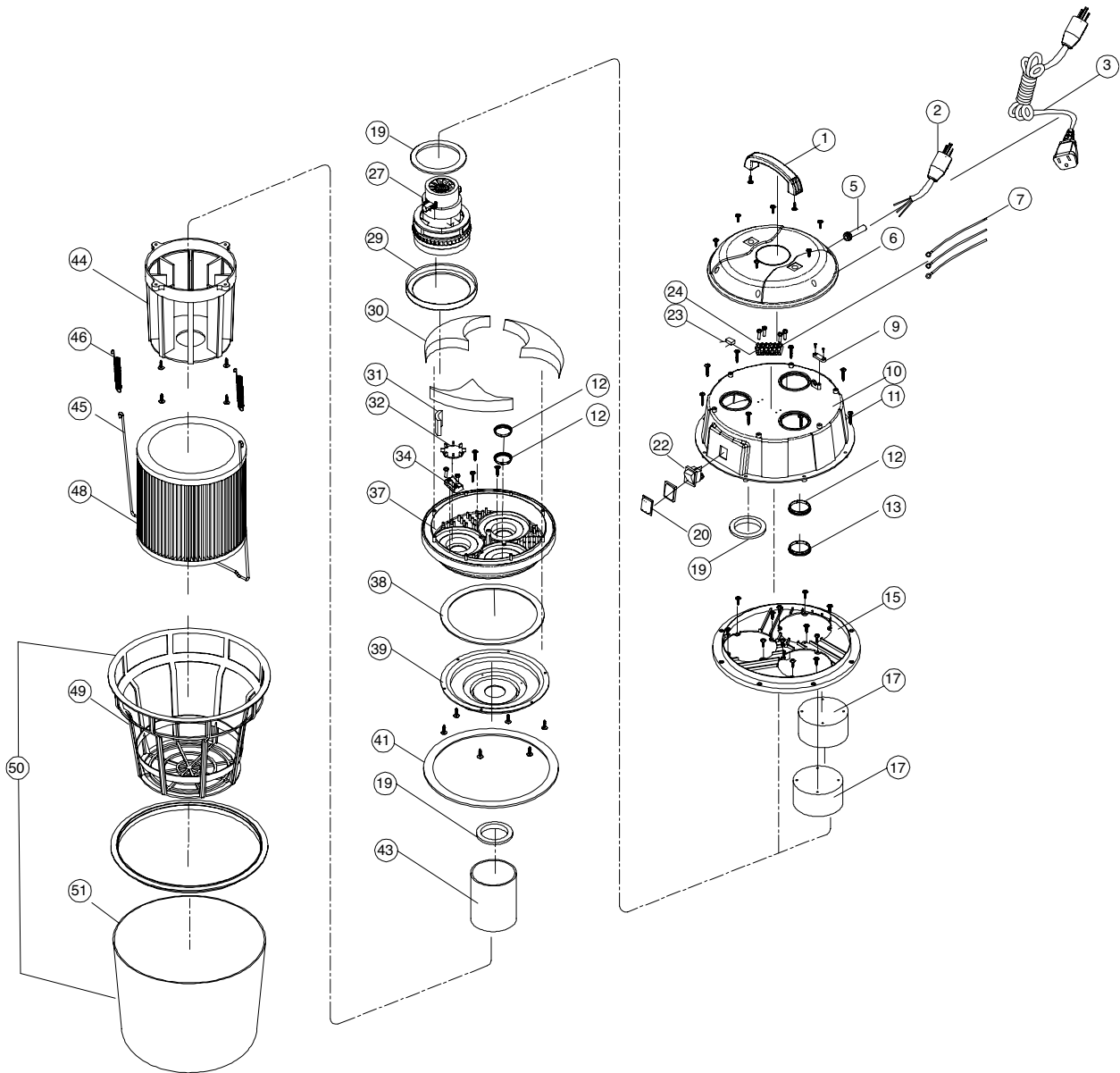

ref #	item #	description
1	WD20	HANDLE
2	WD66C	POWER CORD
3	WD66	EXTENSION CORD
5	WD34	CORD PROTECTOR
6	WD65	TOP COVER
7	WD15W	MOTOR CONNECTION WIRE
9	WD17	WIRE PLATE
10	WD16	MIDDLE SEAT
12	WD82	LOWER BASE BLOCK
13	WD83	TOP BLOCK
15	WD14B	MOTOR SEAT
17	WD84	BLOCKER
19	WD53	GASKET
22	WD67	POWER SWITCH
23	WD206	CAPACITOR
24	WD207	TERMINAL BLOCK
27	WD15	MOTOR

ref #	item #	description
29	WD68	MOTOR GASKET
30	WD70	SPONGE
31	WD69	SQUARE SPONGE
32	WD85	REAR WHEEL PLATE
34	WD166	PLATE B
37	WD87	HOUSING BASE
38	WD201	GASKET
39	WD10	BASE COVER
41	WD165	GASKET
43	WD9	FLOAT
44	WD8	FRAME
46	WD37	SPRING
47	WD35	HOOK
48	WD36	PAPER FILTER
49	WD7	FILTER FRAME
50	WD3	FILTER ASSY
51	WD148	FABRIC

Model PF54 Parts

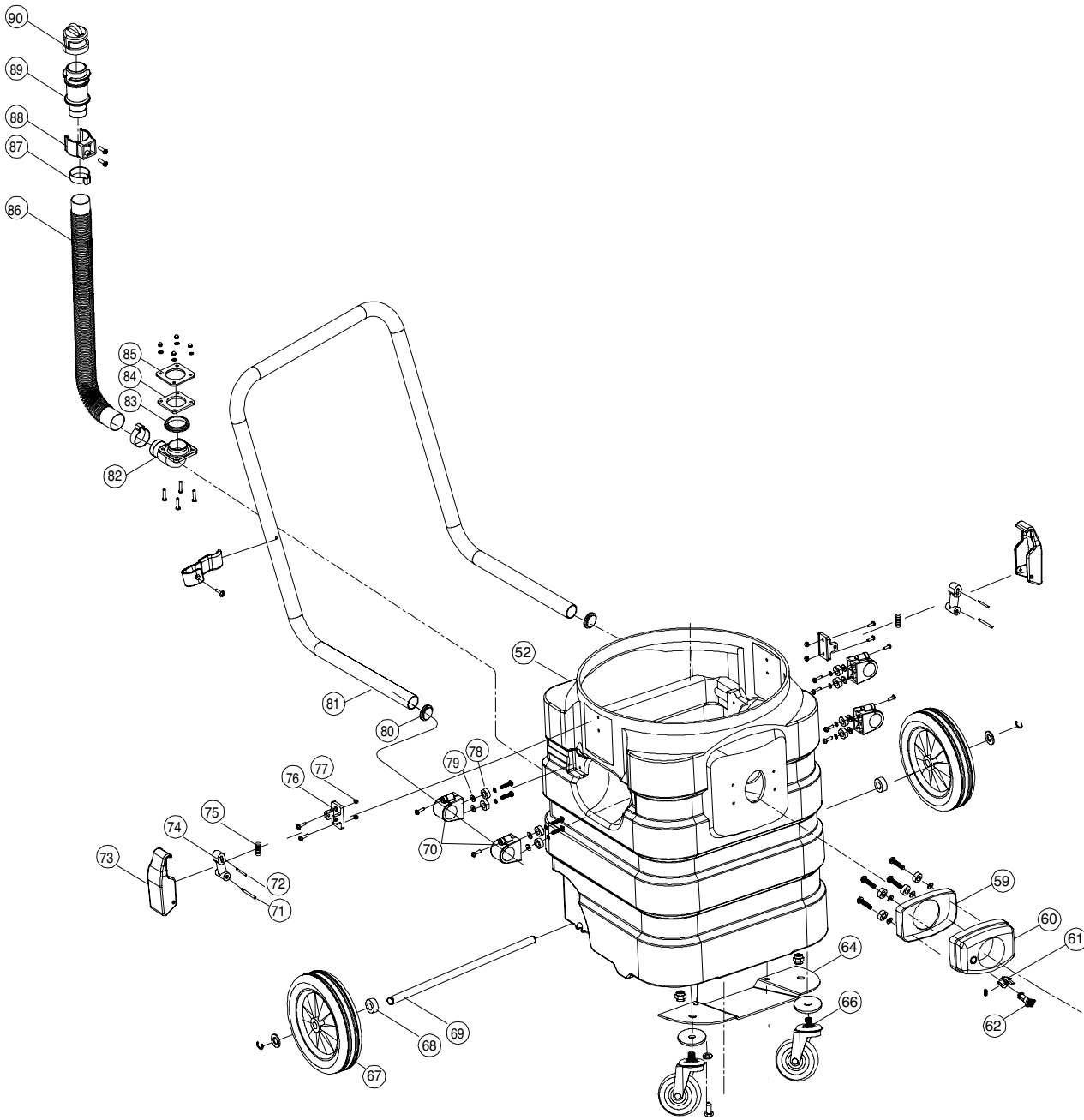

ref #	item #	description
52	WD120	TANK
59	WD50	RUBBER WASHER
60	WD45	SUCTION COUPLER
61	WD86	BUTTON BASE
62	WD46	BUTTON
64	WD167	WHEEL MOUNT BRACKET
66	WD123M	FRONT WHEEL
67	WD124M	REAR WHEEL
68	WD136	WHEEL COVER
69	WD125	AXEL
70	WD121	HOLDER
71	WD131	CLIP PIN
72	WD129	CLIP PIN
73	WD63	CLIP
74	WD127	CLAMP HOLDER
75	WD52	SPRING
76	WD128	CLIP BASE
77	WD44	HEX NUT
78	WD202	WASHER
79	WD77	RUBBER WASHER
80	WD133	COVER
81	WD132	HANDLE
82	WD141	BEND CONNECTOR
83	WD187	BOTTOM SEAL
84	WD188	TOP SEAL
85	WD189	FIXER PLATE
86	WD143	HOSE
87	WD190	CLAMP
88	WD146	HOOK
89	WD144	CONNECTOR B
90	WD145	TOP COVER

Model PF54 Parts

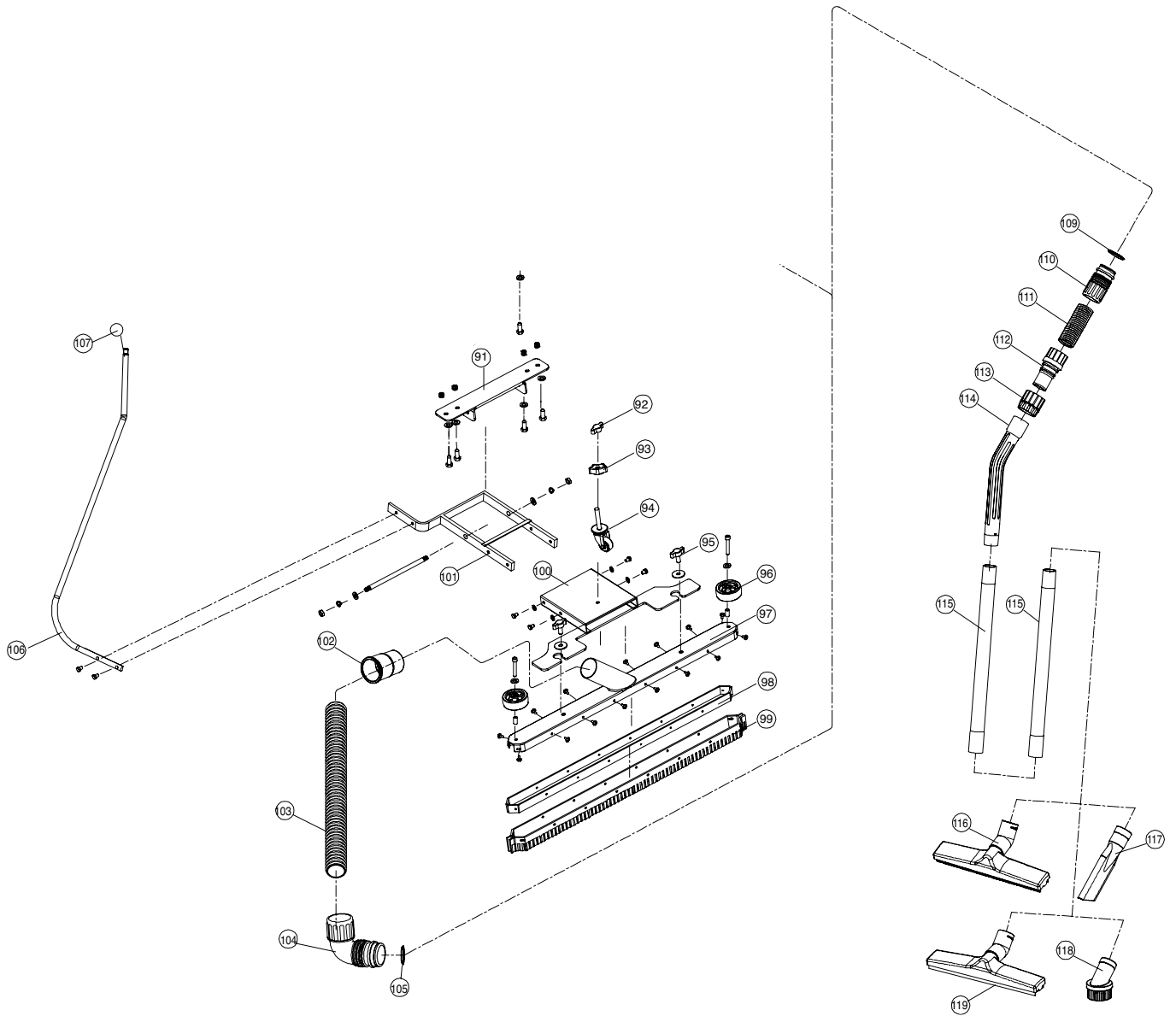

ref #	item #	description
91	WD168	U-SHAFT
92	WD169	BUTTON
93	WD170	FIXED NUT
94	WD171	ADJUSTED WHEEL
95	WD172	BUTTON
96	WD173	WHEEL
97	WD174	SQUEEGEE BODY
98	WD175	BLADE BRACKET
99	WD176	BLADE
100	WD177	FIXED PLATE 2
101	WD179	PEDAL BRACKET
102	WD180	CONNECTOR
103	WD181	HOSE
104	WD182	BEND CONNECTOR
105	WD183	SEAL

ref #	item #	description
106	WD184	ADJUSTER LEVER
107	WD186	ADJUSTER LEVER KNOB
109	WD191	GASKET
110	WD24	CONNECTOR
111	WD25	HOSE
112	WD26	CONNECTOR
113	WD27	FIXER
114	WD28	BEND CONNECTOR
115	WD29	EXTENSION WAND
116	WD112	BRUSH NOZZLE ASS'Y
117	WD32	CREVICE TOOL
118	WD33	ROUND BRUSH
119	WD30A	SQUEEGEE NOZZLE ASS'Y
	WD157	DRAIN HOSE ASS'Y
	FM100H	FRONT MOUNTED SQUEEGEE ASS'Y

Model PF54 Parts -Squeegee Assembly

Installing Instructions - FM100H

FRONT MOUNT SQUEEGEE INSTRUCTIONS

1. Remove vacuum head and filters from the vacuum.
2. Install axle mounting plate to bottom of unit. *See fig 1*
3. Attach handle bracket to squeegee bracket.
4. Attach squeegee bracket to the axle bracket. *See fig 2*
5. Attach handle to handle bracket. *See fig 3*
6. Attach handle holder to machine handle. *See fig 4*
7. Attach squeegee to squeegee bracket. *See fig 5*
8. Adjust compensating wheel as necessary.

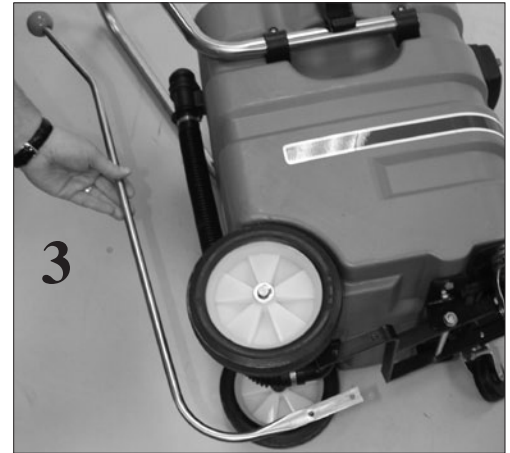

TROUBLE SHOOTING GUIDE

Loss of Suction

CAUSE:

- 1) Tank full.
- 2) Dry filter assembly clogged.
- 3) Clogged hose or wand.
- 4) Tank rim is dented.
- 5) Loose or broken fan.
- 6) Motor not working.
- 7) Float not functioning.
- 8) Seal worn.

SOLUTION:

- 1) Empty Tank
- 2) Clean cloth filter.
- 3) Remove obstruction.
- 4) Replace tank.
- 5) Contact manufacturer or service center.
- 6) Contact manufacturer or service center.
- 7) Check to see if float moves freely or tank is full.
- 8) Replace seal.

Motor is not running

CAUSE:

- 1) Broken switch.
- 2) Defective power cord.
- 3) Defective motor.

SOLUTION:

- 1) Contact manufacturer or service center.
- 2) Contact manufacturer or service center.
- 3) Contact manufacturer or service center.

Dust blowing from unit when running

CAUSE:

- 1) Cloth filter dirty.
- 2) Cloth filter is torn.
- 3) Cloth filter is not installed.

SOLUTION:

- 1) Clean cloth filter.
- 2) Replace filter.
- 3) Install cloth filter, when vacuuming very fine dust,

Water blowing from unit when running

CAUSE:

- 1) Tank is full of liquid.
- 2) Sudsy or foamy liquid is being picked up.

SOLUTION:

- 1) Empty tank.
- 2) Add defoamer to tank.

The Powr-Flite Limited Warranty

The manufacturer warrants to the original purchaser that products manufactured are free from defects, provided such goods are installed, operated and maintained in accordance with written manuals or other instructions for a period of 1 year from date of purchase on workmanship, motor, and parts. In case you, as our customer, meet any trouble with your machine, contact a Powr-Flite representative, who will be happy to be of service to you and will take care of any warranty issues.



3101 Wichita Court
Fort Worth, TX 76140
800.880.2913
www.Powr-Flite.com