

Power-Flite®

COMMERCIAL FLOOR CARE EQUIPMENT

Edger/Disc Sander Model SD70

OPERATING INSTRUCTIONS

COMMERCIAL EDGER

CONGRATULATIONS

YOU HAVE JUST ACQUIRED A HIGH QUALITY SANDER.
PLEASE READ THIS MANUAL CAREFULLY BEFORE
OPERATING YOUR NEW SANDER. KEEP MANUAL ON
HAND FOR FURTHER REFERENCES.



TECHNICAL MACHINE SPECIFICATIONS

Single-phase AC motor	115V/60 Hz
Motor power	1800 W
Sandpaper disk	7 inches
Disk speed	4300 RPM
Machine weight	20 lbs.



Save These Instructions

CONTENTS

Important Parts of the Machine	3
Machine Set-up	
Fitting the dustbag	4
How to Operate the Machine	
Fitting the sandpaper	4
Sanding angle adjustment	5
Connection to power supply	5
Starting the machine	5
How to operate the machine	5
Maintenance	
Brush replacement	6
Changing and adjusting the V-belt	7
Cleaning the disk pulley	8
Wheel replacement	9
Dust suction	9
Equipment	9
Assembly Drawing and Spare Parts List	10

CAUTION

Read all instructions, warnings and cautions before using!

These guidelines are provided for your protection and convenience. Please read them carefully. If you have any questions regarding the use of your equipment call Powr-Flite Technical Service at 800.880.2913. This manual contains important information for the use of this machine and safety instructions for preventing personal injuries, damage to the machine or to other property. Failure to adhere to instructions provided can potentially void any warranties.

INTRODUCTION

Congratulations on your purchase of a Powr-Flite Edger Sander. Read this entire manual before operating or servicing the sander.

Unpacking the Edger Sander

The Powr-Flite Edger Sander was thoroughly inspected, tested, and packaged to deliver the equipment in good operating condition. The freight carrier received and signed for the equipment in good condition. Damage can occur during shipping and to protect your interest, all cartons must be inspected for damage (including any concealed damage) that might have occurred during shipment. Any damage is the responsibility of the freight carrier and should be reported immediately to the carrier. It is your responsibility to issue a claim and to receive compensation from the freight carrier for any damage done in transit. Shipping damage is not warranted.



IMPORTANT PARTS OF THE MACHINE

Electric switch

The machine is fitted with a protected switch.

Push the button to "ON" to start the motor and the "OFF" to stop.



Fig. 1

Suction dust tube

The suction dust tube is placed at the back of the machine next to the dustbag holder.

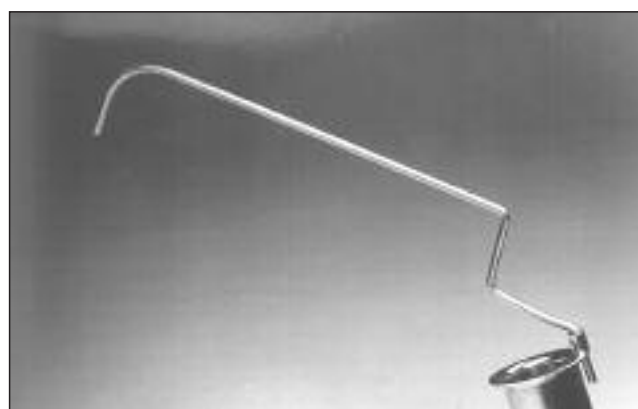

Fig. 2

Dustbag

The dustbag must be clipped to the suction tube and its holder placed inside the bag.



Fig. 3

V-belt tensioner

The V-belt tensioner is located at the back of the machine and underneath it.



Fig. 4



Fig. 5

Sandpaper disk holder

The sandpaper disk holder is a tapered nut.

MACHINE SET-UP



Fitting the dustbag

After unpacking the machine, proceed as follows:

- ① Fit the suction tube
- ② Fit the dustbag holder
- ③ Fit the dustbag

HOW TO OPERATE THE MACHINE



Fig. 6

Fitting the sandpaper

- ① **Sandpaper discs with an adhesive backing:** use 178 mm. disks and simply place the sandpaper disk on the sanding disk (Fig. 6).



Fig. 7

- ② **Sandpaper discs with a paper backing:** use 178 mm disks with a 22 mm hole.

- ③ Take off the taper nut.

- ④ Place the sandpaper disk, then the taper nut and secure it. (Fig. 7).

HOW TO OPERATE THE MACHINE

- 5 Fasten the nut with the wrench included in the wrench kit (Fig. 8).



Fig. 8

Sanding angle adjustment

The sanding angle is set up at the factory for sanding with a 1/3 disk.

If you wish to change this angle, unloosen the nut securing the wheel shaft. Then move the wheels up and down to change the working angle as follows:

Wheels down: the machine sands point first

Wheels up: the machine sands flat. (Fig. 9).

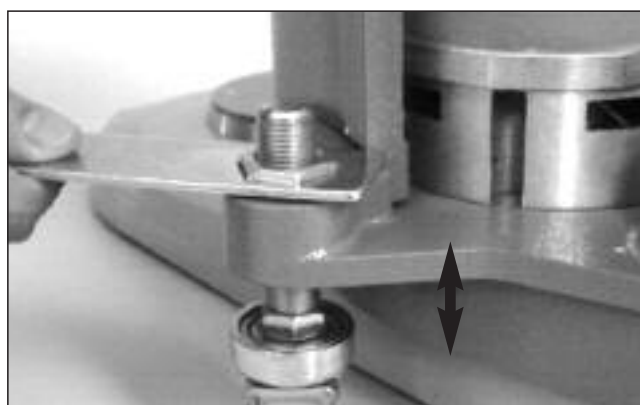

Fig. 9

Connection to power supply

The sander must be connected to a 115V/60 Hz power supply with grounded plugs.



CAUTION!

To prevent electrocution keep the machine in a dry place. Do not expose the machine to rain.

Use 3 wire of 14 AWG section cable.

The machine cord, extension cords and connection plugs must be in perfect condition.

Starting the machine

- 1 Before connecting the cord to the power supply make sure that the switch is in the "0" position.
- 2 Place the machine in a vertical position and tilted backward.
- 3 Hold the machine with your left hand.
- 4 Push the switch down with your right hand.
- 5 Press the disk on the floor and start sanding.
- 6 Do not press on the sander. Its own weight and the high speed of the disk are sufficient for sanding.

How to use the machine

The sander is usually held with both hands and placed between the legs with your body leaning backward. You can also use it on your knees.

The high speed of the disc will sand the surface without any additional pressure. Do not press on the edger while sanding.

Pressing on the machine could leave marks on the floor, burn the wood, overheat the motor and wear the brushes faster; shortening the life of the machine.

MAINTENANCE

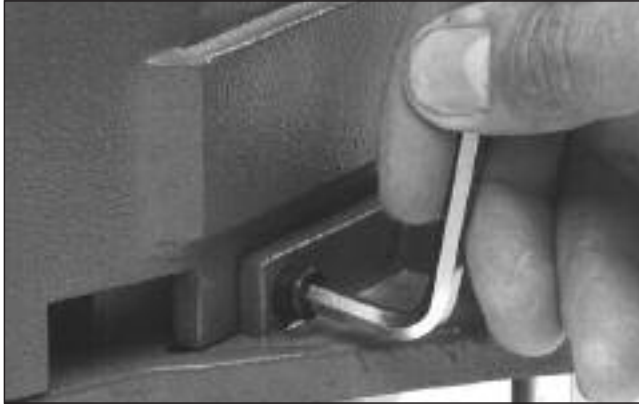

Fig. 11



Fig. 12



Fig. 13



Fig. 14

Brush replacement

- 1 Disconnect the machine from the power supply.
- 2 Remove side and front screws.(Fig.11).

- 3 Remove the vertical bracket (Fig. 12).

- Remove the plastic cover securing the brushes with a screwdriver (Fig. 13).
- Remove the brushes carefully and replace them (Fig. 14).

IMPORTANT:

The motor is fitted with two brushes, one at each side of the motor.

In universal motors, the brushes have an approximate life of 500 hours of machine use under normal conditions and without pressing too much on the sander when working.

The brushes and their housing should be cleaned using compressed air.

Inspect brushes on a regular basis. They should be replaced before the automatic disconnection stops the machine. This will occur when the brushes are worn out and less than 1/8 inch long. Damage can occur if the brushes are allowed to wear completely out. Make sure you always have a brush set available.

MAINTENANCE

Changing and adjusting the V-belt

Due to the high speed of the motor, it is important to check the tension of the V-belt. **DO NOT TIGHTEN THE BELT TOO MUCH.**

This type of machine, equipped with high speed motors, needs a regular replacement of the belt.

- 1 For adjusting or replacing the belt, disconnect the power supply.
- 2 Loosen both screws without removing them (Fig. 15).



Fig.15

- 3 Loosen the nut without removing it (Fig. 16).

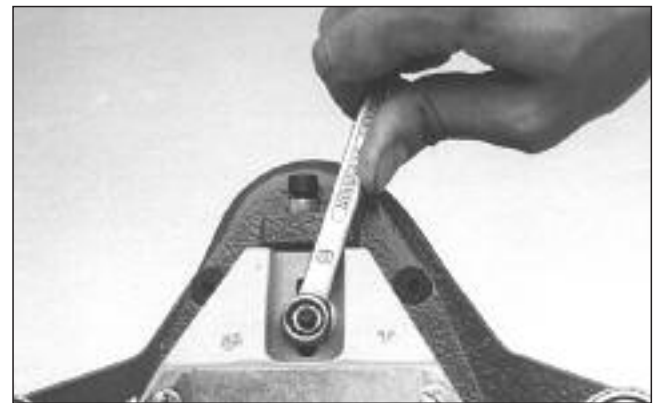

Fig.16

- 4 The belt is either tightened or loosened when adjusting or loosening the tension screw (Fig. 17).

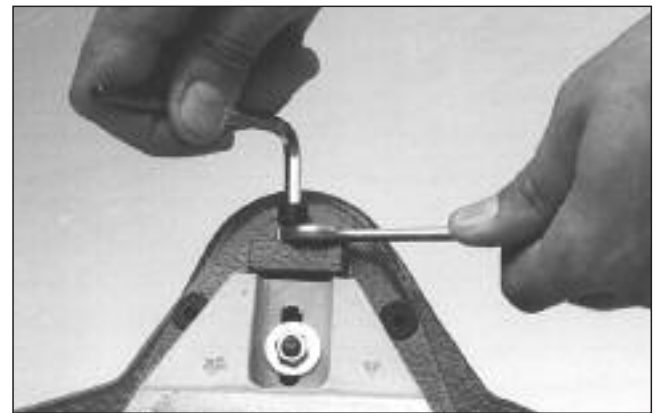

Fig.17

- 5 Place the machine as shown in Fig. 18 and remove the four screws securing the guard which covers the belt (Fig. 18).



Fig.18

MAINTENANCE



Fig.19

- ◀ 6 Take off the taper nut which holds the sandpaper (Fig. 19).

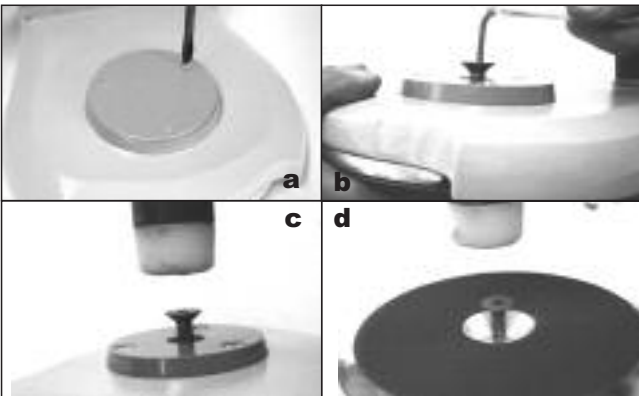

Fig.20

- ◀ 7 Remove the guard which covers the central screw with a screwdriver. Holding the disk with one hand, ease the central screw with an Allen wrench (Fig.20 a - b).

To pull out the pulley from the bearing, strike the central screw slightly with a plastic hammer (Fig.20 c).

To set up the pulley again, tighten the screw at the disk side, adjust the pulley to the bearing and strike the screw slightly with a plastic hammer until the pulley gets in (Fig.20 d).

Remove the screw and set it in place again.



Fig.21

- ◀ 8 When the disk and the pulley are loose, lift them up, remove the belt and replace it by a new one (Fig. 21).

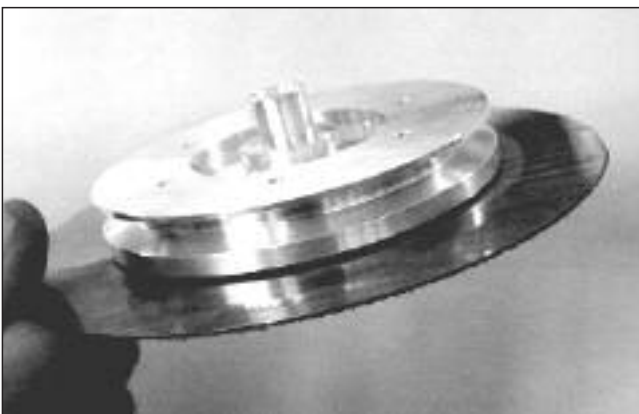

Fig.22

Cleaning the disk pulley

Material debris, waxes, glues, plasters, leveling pastes, etc. could stick to the disk pulley causing the machine to be out-of-balance and show an unusual belt wear.

Clean the pulley track where the belt slides. (Fig. 22).

MAINTENANCE

Wheel replacement

For proper machine operation, inspect the wheels for wearing and to ensure the working angle is not altered as the wheels wear down.

The proper working angle is necessary to maintain:

- Adequate dust suction
- proper sanding finish

Replace wheels as required to maintain the proper working angle.

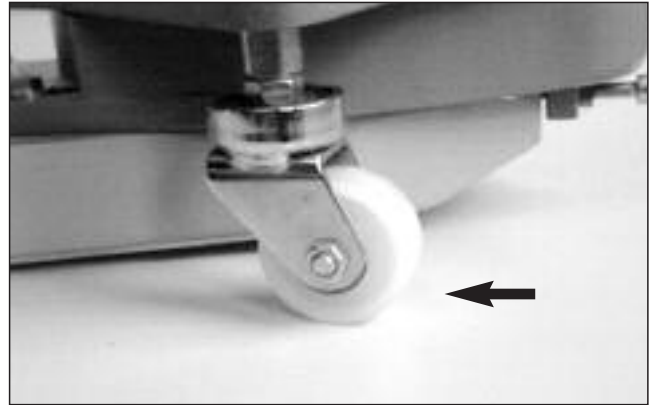

Fig.23

Dust suction

The machine is equipped with a dustbag. For optimum performance:

The working angle should be the adequate. A tilted machine is not able to vacuum properly.

- 2 Empty the dustbag when it is 1/3 full. Suction becomes less effective when the bag gets too full.
- 3 Do not use the machine with more than one disk of sandpaper.
- 4 The bag is made with a special material which lets air through, but not dust.
- 5 Change the dustbag several times a year, even if it is not torn; the aging of material due to dust accumulation will obstruct the air circulation and therefore cause faulty suction.



Fig.24

EQUIPMENT

Tool bag

A tool bag with wrenches is provided for machine maintenance.



Fig.25

ASSEMBLY DRAWING AND SPARE PARTS LIST

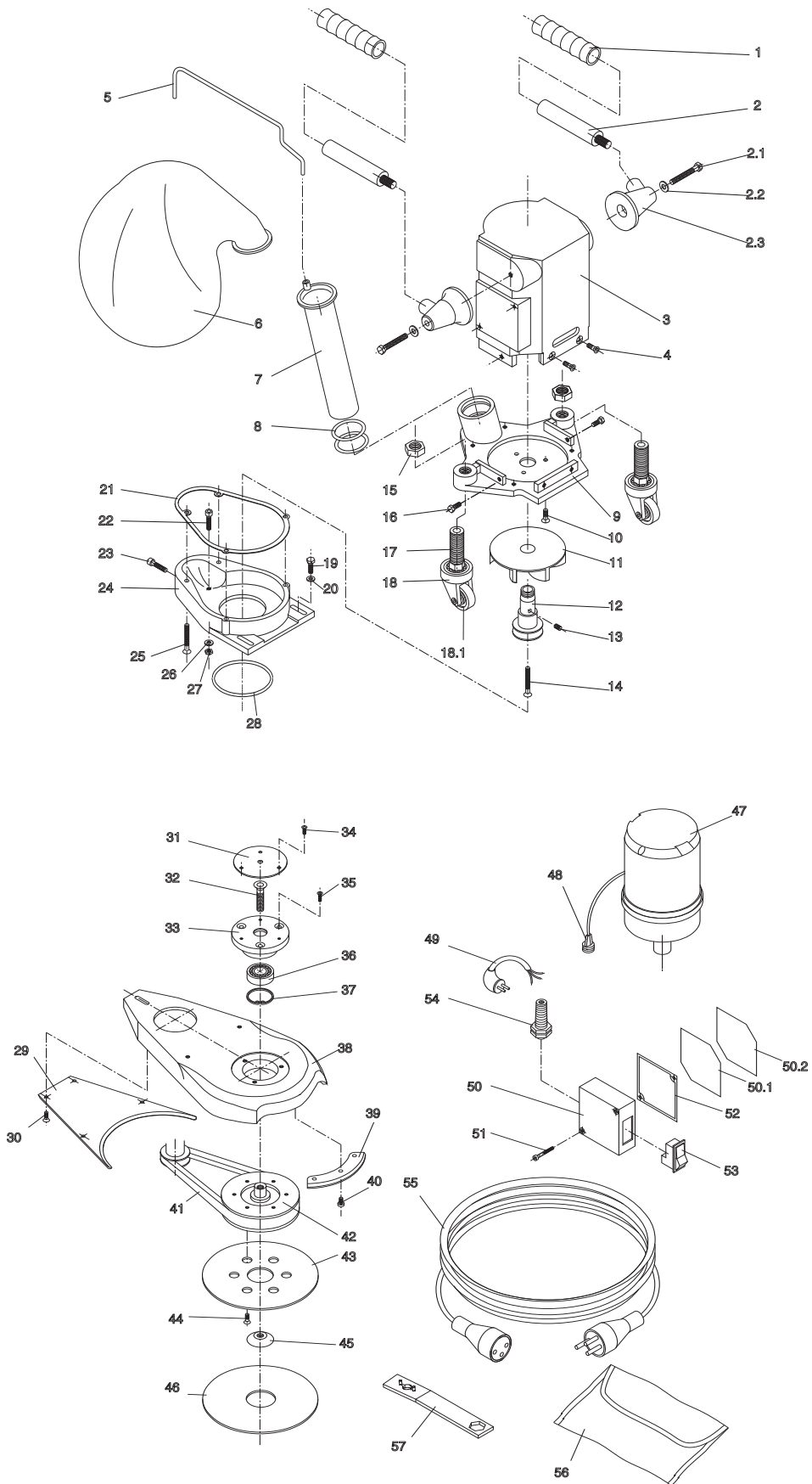

ASSEMBLY DRAWING AND SPARE PARTS LIST

ref#	part #	desc
1	SD157	HILT
2	SD158	HANDLE
2.3	SD159	HANDLE BRACKET
5	SD160	DUST BAG CLAMP
6	SD161	DUST BAG
8	SD162	O RING OR 44,2 x 3
11	SD163	FAN
12	SD164	MOTOR PULLEY (disc ø 178 mm)
18.1	SD165	WHEEL ø 40

ref#	part #	desc
21	SD166	GASKET
28	SD167	O RING OR 90 X 3
32	SD168	SCREW DIN 7991 M 10 x 40
41	SD169	BELT Z - 19 3/4 (disc ø 178 mm)
43	SD170	STEEL DISC ø 178 mm
45	SD172	CONICIAL NUT
46	SD173	FELT DISC ø 178 mm
47	SD174	UNIVERSAL MOTOR MOG USA
57	SD175	KEY

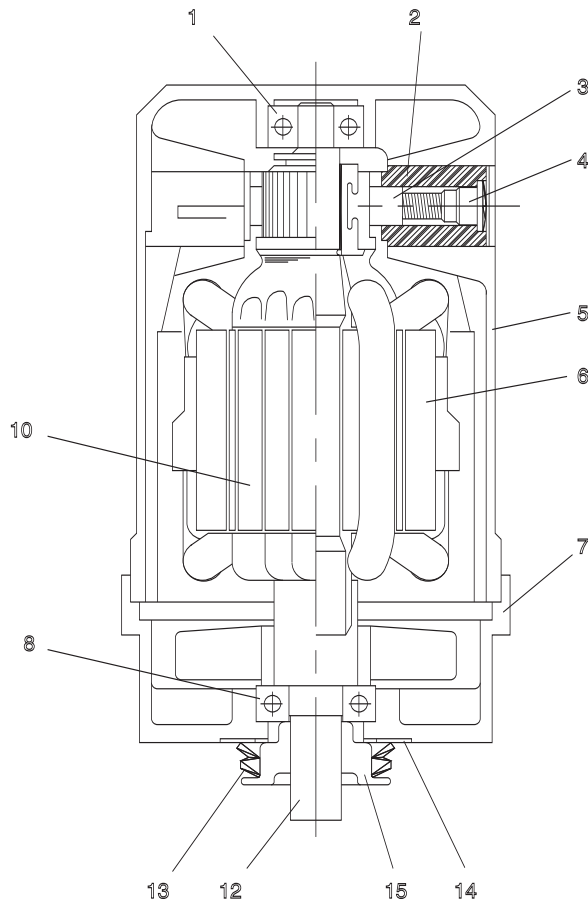

ref#	part #	desc
1	SD176	BALLBEARING 6001 VVC3
2	SD177	BRUSH BRACKET
3	SD178	BRUSHES
4	SD179	COVER
5	SD180	MOTOR HOUSING
6	SD181	STATOR USA
7	SD182	COVER
8	SD183	BALLBEARING 6202 VVC3
10	SD184	ROTOR USA
13	SD185	V-RING JOINT V 28 S
14	SD186	AXIAL DISC INA AS3047
15	SD187	SPACER

DECLARATION OF CONFORMITY

DECLARATION OF CONFORMITY

QUIDE, S.A. declare under our responsibility that the floor sanding machine model **EASY 7** meets the requires standards of safety and health with respect to the design and manufacture of machinery, according to the below mentioned regulations.

EEC regulations regarding to:

Machines (89/392/EEC)
Low voltage (73/23/EEC)
Electromagnetic compatibility (89/336 EEC)
(Last changed through 93/68/EEC from 22.7.1993.)



In conformity with the following standards:

EN 292 Part 1 and Part 2 (Safety of machinery, equipment and systems)
EN 60204.1 (Electrical equipment of industrial machines)

WARRANTY

WARRANTY

Powr-Flite warrants new products manufactured and sold under the name of Powr-Flite to be free from defects in materials and workmanship under normal use and service, provided such goods are installed, operated and maintained in accordance with written manuals or other instructions for a period of 1-year. Powr-Flite's obligation under this warranty is limited to repairing or replacing, at our option, such products or parts which are returned to our factory authorized service center, within the warranty period and are found to be defective in materials or workmanship. This warranty does not apply to excessive wear caused by abnormal use, nor does it apply to normal wear parts such as main cable, wheels, switches, relays, brushes, rubber parts, hoses and bearings.

This warranty is in lieu of all other warranties expressed or implied, and releases Powr-Flite from all other obligations and liabilities.

Powr-Flite assumes no responsibility for repairs, and the costs of such repairs, made or attempted by persons other than those specifically authorized by Powr-Flite. Any such unauthorized repairs shall void this warranty.

Powr-Flite
COMMERCIAL FLOOR CARE EQUIPMENT

A Tacony Company

Ft. Worth, TX 76140

1-800-880-2913