

# **Power-Flite**<sup>®</sup>

**COMMERCIAL FLOOR CARE EQUIPMENT**

## **Orbital Floor Sander Model SD150**



### **OPERATING INSTRUCTIONS**

COMMERCIAL ORBITAL SANDER

#### **CONGRATULATIONS**

YOU HAVE JUST ACQUIRED A HIGH QUALITY SANDER. PLEASE READ THIS MANUAL CAREFULLY BEFORE OPERATING YOUR NEW SANDER. KEEP MANUAL ON HAND FOR FURTHER REFERENCES.

### **TECHNICAL MACHINE SPECIFICATIONS**

<b>AC motor</b>	<b>115V/60 Hz.</b>
<b>Motor power</b>	<b>1.5 HP, 3,460 RPM</b>
<b>Current</b>	<b>Off load 6 A</b>
	<b>On load 12 A (average)</b>
	<b>Startup 15A</b>
<b>Vacuum motor</b>	<b>115V/60 Hz - 230W.</b>
<b>Abrasive</b>	<b>15fl" (400 mm) x 4fi" (115 mm)</b>
<b>Machine weight</b>	<b>133 lbs. (60 kg)</b>



**Save These Instructions**

## CONTENTS

<b>Safety Instructions</b> .....	<b>3</b>
<b>Important Parts of the Machine</b> .....	<b>4</b>
<b>Machine Set-up</b>	
Setting up the dust bag .....	<b>5</b>
Setting up the handle support .....	<b>5</b>
Fitting the sandpaper .....	<b>5</b>
<b>How to Start the Machine</b>	
Setting up and leveling the sanding plate .....	<b>6</b>
Connection to power supply .....	<b>7</b>
Starting the machine .....	<b>7</b>
<b>How to Operate the Machine</b> .....	<b>7</b>
<b>Maintenance</b>	
Replacement of the wheels .....	<b>7</b>
Replacement of the lamp .....	<b>8</b>
Dust suction .....	<b>8</b>
<b>Accessories</b> .....	<b>9</b>
<b>Assembly Drawing and Spare Parts List</b> .....	<b>10</b>

## CAUTION

Read all instructions, warnings and cautions before using!

These guidelines are provided for your protection and convenience. Please read them carefully. If you have any questions regarding the use of your equipment call Powr-Flite Technical Service at 800.880.2913. The manual contains important information for the use of this machine and safety instructions for preventing personal injuries, damage to the machine or to other property. Failure to adhere to instructions provided can potentially void any warranties.

## INTRODUCTION

Congratulations on your purchase of a Powr-Flite Orbital Sander. Read this entire manual before operating or servicing the sander.

### Unpacking the Orbital Sander

The Powr-Flite Orbital Sander was thoroughly inspected, tested, and packaged to deliver the equipment in good operating condition. The freight carrier received and signed for the equipment in good condition. Damage can occur during shipping and to protect your interest, all cartons must be inspected for damage (including any concealed damage) that might have occurred during shipment. Any damage is the responsibility of the freight carrier and should be reported immediately to the carrier. It is your responsibility to issue a claim and to receive compensation from the freight carrier for any damage done in transit. Shipping damage is not warranted.





## SAFETY INSTRUCTIONS



**Read these instructions carefully before operating or attempting to carry out any service or maintenance procedure on the machine. To reduce the risk of fire, electric shock and personal injury when using electrical tools, the following basic safety precautions should always be taken.**

- Operators must be trained to operate this machine and must read and understand this manual completely before operating the equipment.
- Machines can cause flammable materials and vapors to burn. Do not use the machine with or near solvents, thinners, fuels, or other flammable materials.
- To prevent the risk of fire or explosion:
  - a) Empty the dustbag when it is 1/3 full.
  - b) Empty the dustbag when the work is over. Do not leave contents in the dust bag.
  - c) Do not put the contents of the dust bag into a fire or furnace.
  - d) Use a hammer and punch to countersink all nails against the floor so that the sanding drum will not touch them and create sparks which might cause a fire in the dust bag.
- Do not use the machine if it is not completely assembled.
- To prevent personal injury, always disconnect the power supply before changing the sandpaper, emptying the dust bag, leaving it unattended or attempting any maintenance or service of the machine.
- To prevent electrocution, avoid contact with grounded devices, i.e. electric stoves, radiators, refrigerators, etc.
- Do not expose the machine to rain.
- Keep the electrical parts dry. The machine should be stored in a dry place.
- When you operate the machine, make sure that the power cord is free from under the sanding plate.
- Check the cord and plugs and replace them if damaged. Do not use the machine if the cord is damaged. Keep the cord away from heat, oil and water.
- Always use a 3-wire electrical cord (GA 14-3) and connect the machine to grounded plugs.
- Make sure that the switch is in the "0" - "Off" position before connecting the machine to the power supply.
- Be careful not to accidentally start the machine, make sure that your hands are empty when you press the switch.
- Always use a dust mask. if the sanding operation is dusty.
- Do not operate the machine when you are tired, avoid positions which can cause fatigue. Keep proper footing and balance at all times.
- Always keep the machine clean. Check it for damaged parts before use, change damaged moving parts and always follow maintenance instructions.
- Keep children away from the machine.

# IMPORTANT PARTS OF THE MACHINE

## Switch

The double-bladed switch is located in the condenser box beside the motor.

When the switch is pushed to the left the motor is off. The motor starts when the switch is pressed to the right.

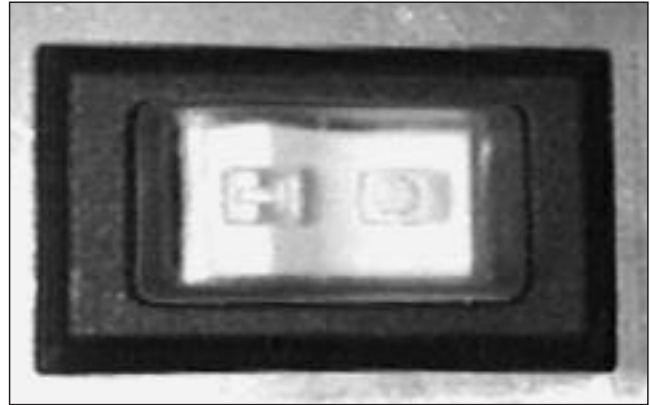

Fig. 1

## Suction system

This is fitted with a suction tube operated by a 230W power motor which suctions dust through a flexible hose when the machine is working.

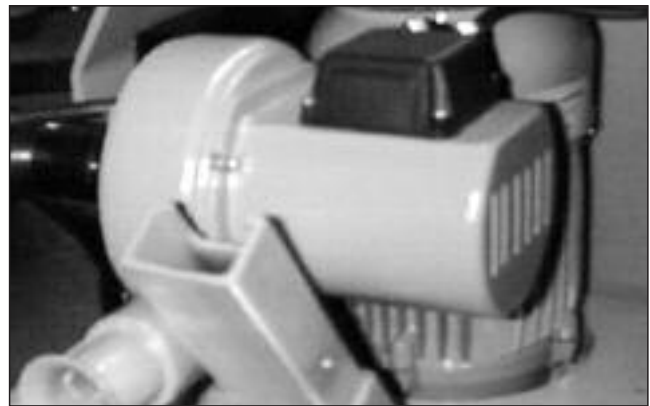

Fig. 2

## Lamp

The PL-9 W type lamp is directly connected to the power supply. This means that the light comes on automatically when the machine is started.

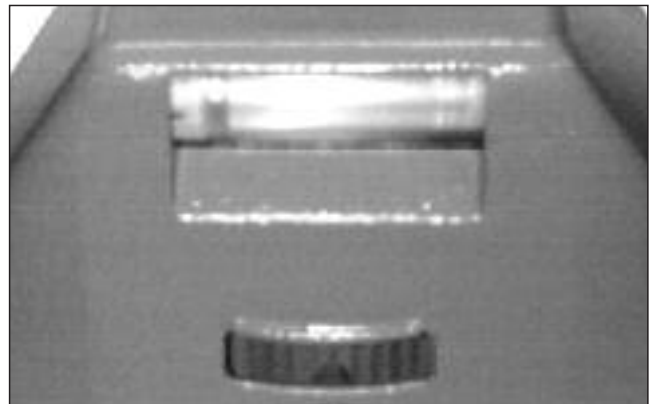

Fig. 3

## Sanding plate holder

This is located underneath the machine and is fitted with 2 pins that secure the sanding plate.

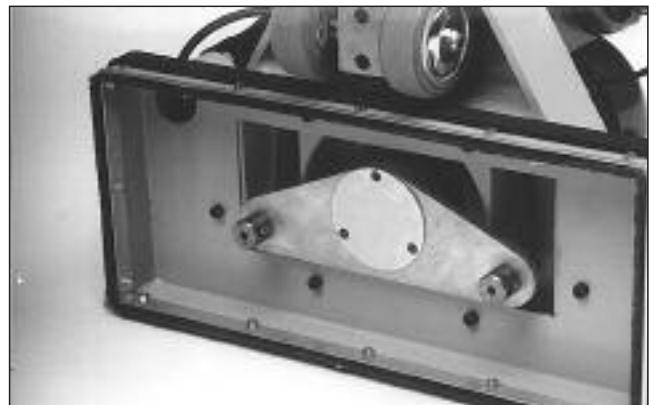

Fig. 4

# MACHINE SET-UP



Fig. 5

## Dust bag

The dust bag must be placed at the suction tube outlet and hung from the machine handle.



Fig. 6

## Setting up the handle

- 1 Loosen the lever.
- 2 Push the handle tube in as far as possible.
- 3 Adjust the lever.

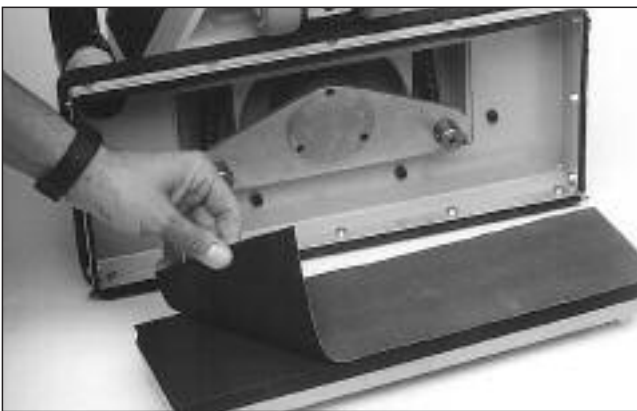

Fig. 7

## Fitting the sandpaper

- 1 **Sandpaper with an adhesive backing.**  
Place the sandpaper on the plate support (Fig. 7).

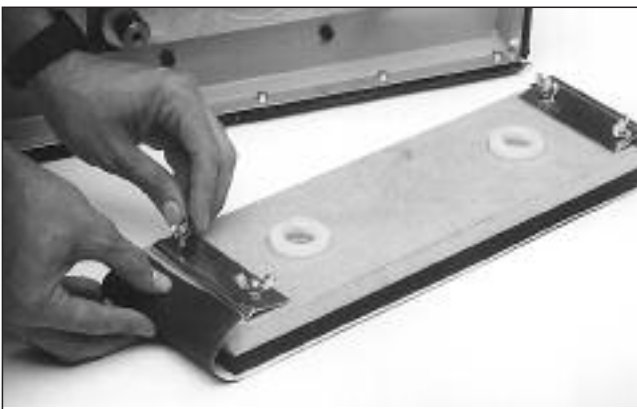

Fig. 8

- 2 **Sandpaper with a paper backing.**

Cut to the appropriate length and hold both ends firmly with the sandpaper holder to prevent the sandpaper from slipping during operation (Fig. 8).

# HOW TO START THE MACHINE

## Setting-up and leveling the sanding plate

- 1 Disconnect the sander from the power supply.
- 2 Place the machine in the position shown in (Fig. 9.)



Fig. 9

- 3 Fit the sanding plate by matching up the two plate holes with the two hooking pins (Fig. 10).



Fig. 10

- 4 To level the height of the caster wheels in relation to the sanding plate, unloosen both screws and turn the eccentric shaft wheels: the wheels will go up and down (Fig. 11).

- 5 The wheels must reach the plate height.



Fig. 11

# HOW TO START THE MACHINE



Fig. 12



Fig. 13

## Connection to power supply

The sander must be connected to a 115V/60 Hz power supply with grounded plugs.

### CAUTION!

To prevent electrocution keep the machine in a dry place. Do not expose the machine to rain.

Use 3-wire (GA 14-3) power cords connected to grounded plugs.

The machine cord, extension cords and connection plugs must be in perfect condition.

## How to start the machine

- 1 Before connecting the cord to the power supply, make sure that the switch is in the "O" position.
- 2 After placing the sander as shown in Fig. 12, push the switch down with one hand and hold the machine with the other.
- 3 Do not press on the sander. Its own weight is sufficient for achieving efficient work.

## How to operate the machine

The sander is usually held by the handle with both hands and rolled along to the places to be sanded. Move the machine to avoid marks on the floor. If the floor is not level, use the support plate for the mesh sandpaper, as shown in (Fig. 13.)

# MAINTENANCE



Fig. 14

## Replacement of the wheels

- 1 Disconnect the machine from the power supply.
- 2 Unloosen and remove both screws from the wheel shaft bracket.
- 3 Remove the wheels beside the shaft.
- 4 Remove the shaft wheels with an hexagonal wrench and replace them.

## Replacement of the lamp

The machine has a light fitted with a PL-9W lamp.

To replace it:

- 1 Remove the front plastic part by gently pressing on its sides (Fig. 15).
- 2 Replace the lamp with a new one (Fig. 16).



Fig.15

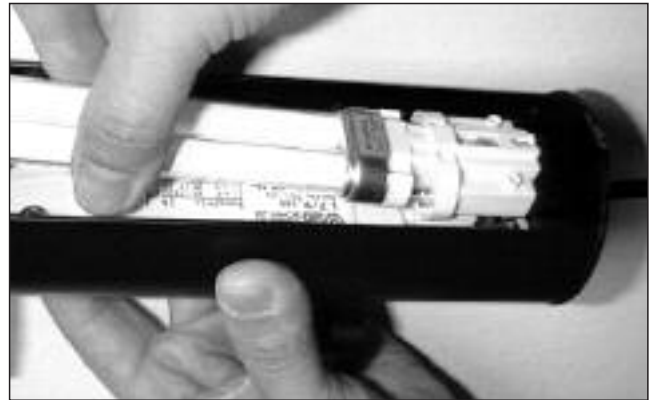

Fig.16

## Dust suction

The machine is equipped with a dustbag.

For optimum vacuum performance:

- 1 The caster wheels should be level with the sanding plate.
- 2 Empty the dustbag when it is 1/4 full. Suction becomes less effective when the bag gets too full.
- 3 Do not use the machine with more than one sheet of sandpaper on the plate.
- 4 The bag is made with a special material which lets air get through it, but not dust.
- 5 Change the dustbag several times a year, even if it is not torn; the ageing of material due to dust accumulation will obstruct the circulation of air and therefore cause faulty suction.



Fig.17

## ACCESSORIES

### Accessories

Included with the machine:

- 2 sanding plates (one is already fitted on the sander).
- 1 dust bag.
- Screen & white pad.
- 3-wire electrical cord (GA 14-3).



Fig.18

# ASSEMBLY DRAWING AND SPARE PARTS LIST

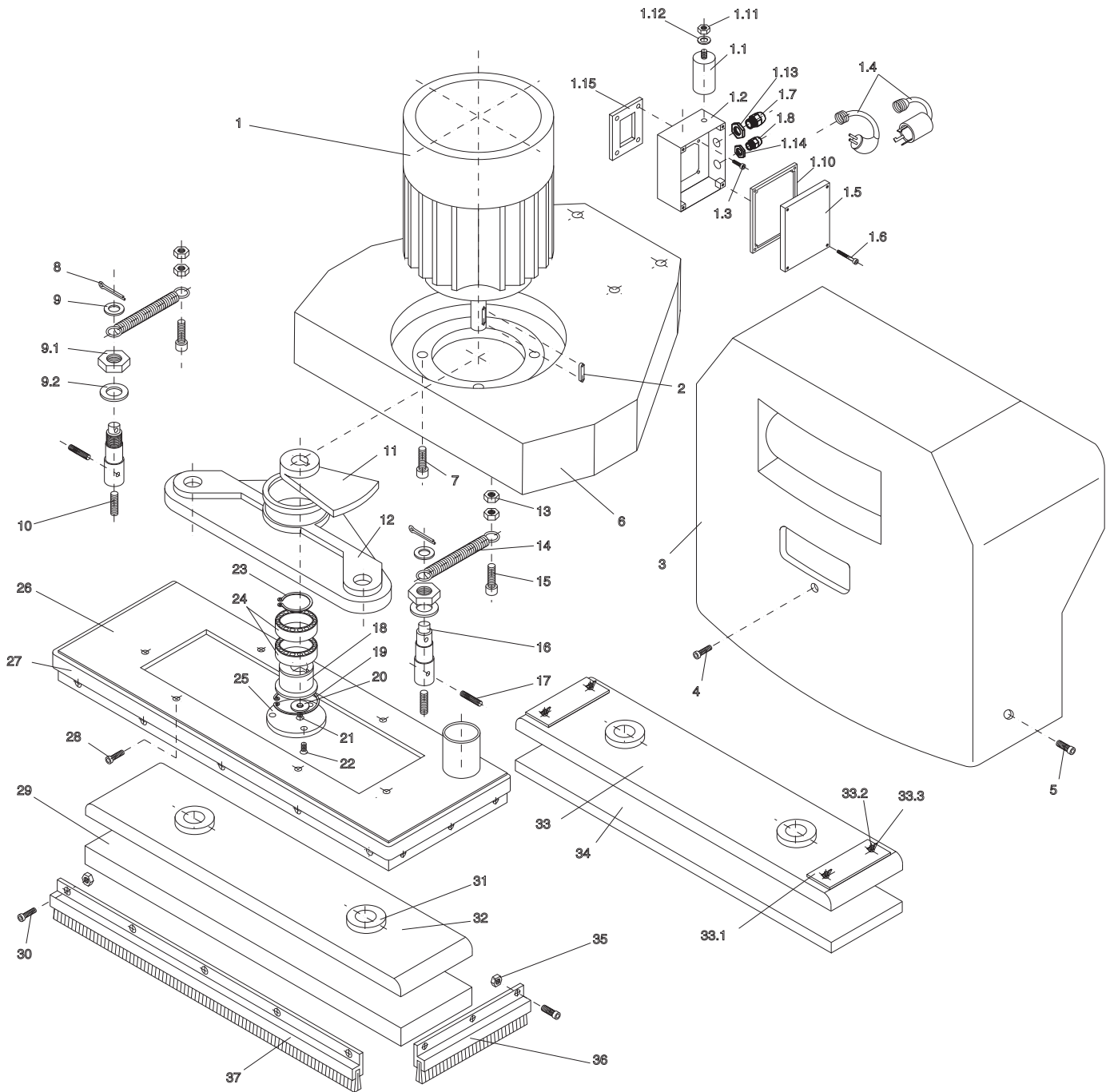

ref#	part #	desc
1.1	SD129	CAPACITOR USA 100 MF
1.4	SD130	CABLE WITH PLUG USA
8	SD131	SPLIT PIN $\varnothing$ 1,5 x 12
14	SD132	SPRING
10	SD133	SCREW DIN 913 M 6 x 5
16	SD134	SHAFT
17	SD135	PRESSIONING SCREW M 10
26	SD136	HOUSING
27	SD137	BUMPER
29	SD138	SANDPAPER SUPPORT
31	SD139	BUSHING
32	SD140	SANDPAPER PLATE
34	SD141	RUBBER
36	SD142	DUST BRUSH (SHORT)

ref#	part #	desc
37	SD143	DUST BRUSH
39.2	SD144	LAMP 9W 115V/60Hz
53	SD145	HANDLE ACCESS M 8
54	SD146	WASHER DIN 125 M 10
59	SD147	PROFIL BRACKET
62	SD148	WHEEL $\varnothing$ 80
68	SD149	SCREW DIN 931 M 8 x 130
82	SD151	FAN HOUSING
79	SD152	VACUUM MOTOR USA
	SD153	DUST BAG
	SD154	PLATE WITH WING NUTS COMPLETE
	SD155	PLATE WITH FOAM COMPLETE
	SD156	VELCRO 115/400

# ASSEMBLY DRAWING AND SPARE PARTS LIST

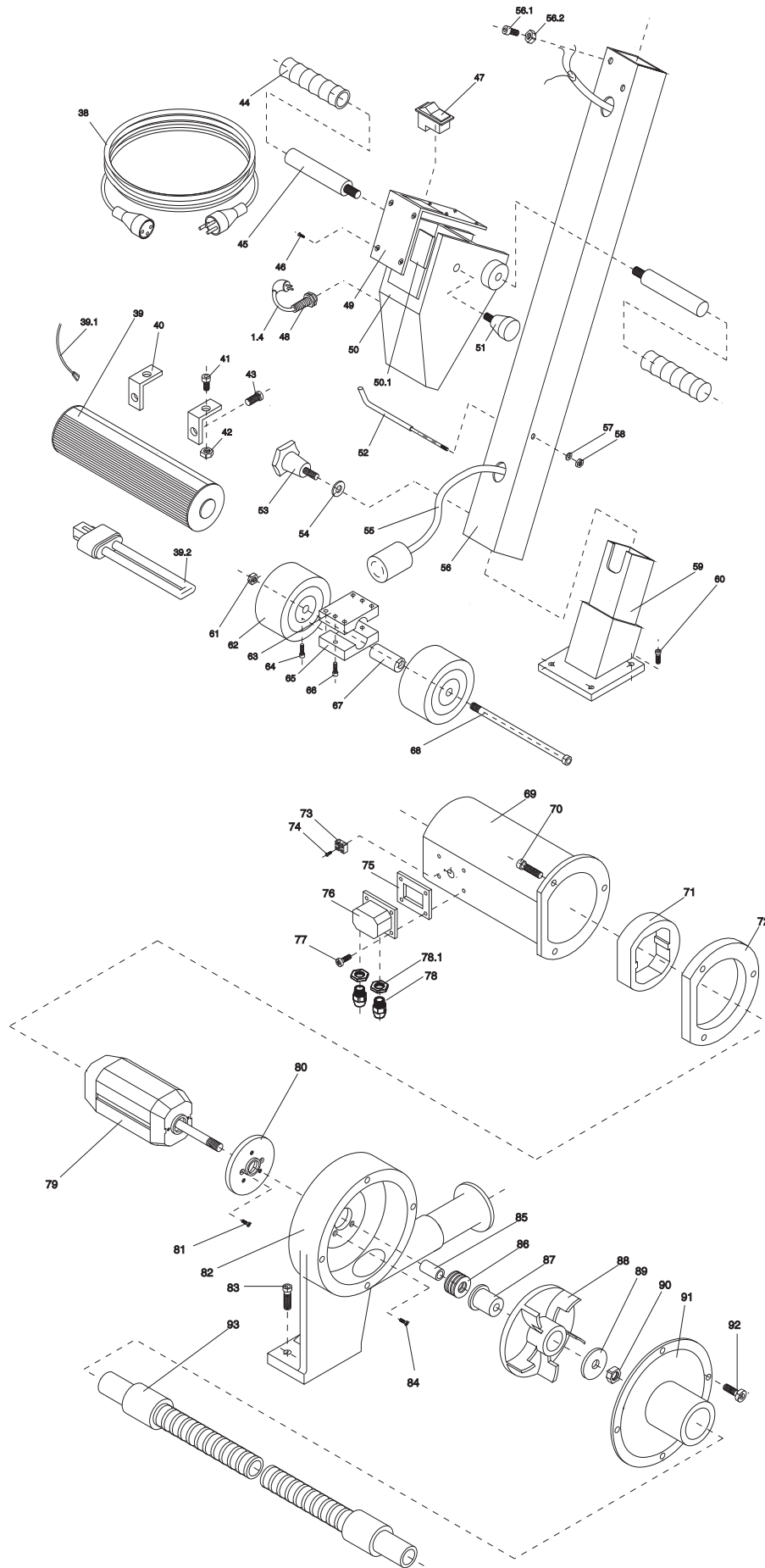

# DECLARATION OF CONFORMITY

## DECLARATION OF CONFORMITY

**GUIDE, S.A.** declare under our responsibility that the floor sanding machine model **ORBI** meets the requires standards of safety and health with respect to the design and manufacture of machinery, according to the below mentioned regulations.

**EEC regulations regarding to:**

**Machines (89/392/EEC)**

**Low voltage (73/23/EEC)**

**Electromagnetic compatibility (89/336 EEC)**

**(Last changed through 93/68/EEC from 22.7.1993.)**

**In conformity with the following standards:**

**EN 292 Part 1 and Part 2 (Safety of machinery, equipment and systems)**

**EN 60204.1 (Electrical equipment of industrial machines)**



## **WARRANTY**

### **WARRANTY**

**Powr-Flite warrants new products manufactured and sold under the name of Powr-Flite to be free from defects in materials and workmanship under normal use and service, provided such goods are installed, operated and maintained in accordance with written manuals or other instructions for a period of 1-year. Powr-Flite's obligation under this warranty is limited to repairing or replacing, at our option, such products or parts which are returned to our factory authorized service center, within the warranty period and are found to be defective in materials or workmanship. This warranty does not apply to excessive wear caused by abnormal use, nor does it apply to normal wear parts such as main cable, wheels, switches, relays, brushes, rubber parts, hoses and bearings.**

**This warranty is in lieu of all other warranties expressed or implied, and releases Powr-Flite from all other obligations and liabilities.**

**Powr-Flite assumes no responsibility for repairs, and the cost of such repairs, made or attempted by persons other than those specifically authorized by Powr-Flite. Any such unauthorized repairs shall void this warranty.**

***Powr-Flite***  
**COMMERCIAL FLOOR CARE EQUIPMENT**

*A Tacony Company*

Ft. Worth, TX 76140

1-800-880-2913

---