

OPERATOR'S MANUAL & PARTS LIST

PRO Sander

Model PROSND



Serial Number: _____

**This machine is for commercial use.
Save These Instructions**

**WARNING: OPERATOR MUST READ AND UNDERSTAND THIS MANUAL
COMPLETELY BEFORE OPERATING THIS EQUIPMENT.**

SAVE THESE INSTRUCTIONS FOR FUTURE REFERENCE

COMMERCIAL USE

WARNING

WARNING: If you do not follow the instructions in a **WARNING**, injury can occur to you or to other personnel.

CAUTION: If you do not read and follow instructions completely, damage can occur to the machine.

* * * * *

WARNING: You must be qualified for the operation of this machine before using it. **READ THE INSTRUCTION MANUAL**

WARNING: Machines can cause flammable materials and vapors to burn. Do not use this machine with or near matches, fuels, grain dust, solvents, thinners, or other flammable materials.

WARNING: Do not use on wet surfaces.

WARNING: Risk of explosion. Floor sanding can result in an explosive mixture of fine dust and air. Use floor sanding machine only in a well-ventilated area.

WARNING: Do not allow machine to be used as a toy. Close attention is necessary when used by or near children.

WARNING: Use only as described in this manual. Use only manufacturer's recommended attachments.

WARNING: Do not use with damaged cord or plug. If machine is not working as it should, has been dropped, damaged, left outdoors, or dropped into water, return it to the rental center.

WARNING: Do not leave machine when plugged in. Unplug from outlet when not in use and before servicing.

WARNING: Do not pull or carry by cord, use cord as a handle, close a door on cord, or pull cord around sharp edges or corners. Do not run appliance over cord. Keep cord away from heated surfaces.

WARNING: Do not unplug by pulling on cord. To unplug, grasp the plug, not the cord.

WARNING: To prevent injury, always remove the electrical plug from the electrical outlet before changing the sandpaper, emptying the bag, leaving the machine, or doing any maintenance to this machine.

WARNING: Do not handle plug or machine with wet hands.

WARNING: Do not put any object into vacuum openings. Do not use with any opening blocked; keep free of dust, lint, hair, and anything that may reduce air flow.

WARNING: Keep hair, loose clothing, fingers, and all parts of body away from openings and moving parts.

WARNING: Turn off all controls before unplugging.

WARNING: Do not use machine to pick up flammable or combustible liquids, such as gasoline, or use in areas where they may be present.

WARNING: To prevent fire explosion when emptying the dust bag:

1. Remove the contents of the dust bag when the bag is 1/3 full.
2. Remove the contents of the dust bag each time you finish using the machine.
3. Do not put the contents of a dust bag into a fire.

WARNING: Do not use machine without proper dust bag.

WARNING: To prevent damage to the power cable, do not let the sandpaper touch the power cable when the machine is running. Always lift the power cable over the machine.

GROUNDING INSTRUCTIONS

This machine must be grounded. If it should malfunction or breakdown, grounding provides a path of least resistance for electric current to reduce the risk of electric shock. This machine is equipped with a cord having an equipment-grounding conductor and grounding plug. The plug must be inserted into an appropriate outlet that is properly installed and grounded in accordance with all local codes and ordinances.

WARNING: Improper connection of the equipment-grounding conductors can result in a risk of electric shock. Check with a qualified electrician or service person if you are in doubt as to whether the outlet is properly grounded. Do not, modify the plug provided with the machine – if it will not fit the outlet, have a proper outlet installed. This machine is for use on a nominal 120-volt circuit, and has a grounded plug that looks like the plug illustrated in sketch (A) in **DIAGRAM 1**. A temporary adapter that looks like the adapter illustrated in sketches (B) and (C) may be used to connect this plug to a 2-pole receptacle as shown in sketch (B) if a properly grounded outlet is not available. The temporary adapter should be used only until a qualified electrician can install a properly grounded outlet (C). The green colored rigid ear, lug, or the like extending from the adapter must be connected to permanent grounds such as a properly grounded outlet box cover. Whenever the adapter is used, it must be held in place by a metal screw.

Note: in Canada, the use of a temporary adapter is not permitted by the Canadian Electrical Code

WARNING: Always use this machine with an AC three-conductor electrical system connected to the electrical ground. Replace any worn, cut, or damaged cords. Replace any damaged plugs, receptacles, or connector bodies.

WARNING: Do not cut, remove or break the ground terminal. Do not try to fit a three-terminal plug into a receptacle or connector body that does not fit the plug. If the receptacle or connector body does not fit the plug, have a qualified electrician make the connection.

WARNING: Do not move the machine over an electrical cord. Always lift the cord over the machine.

WARNING: To reduce the risk of fire use only commercially available floor cleaners and waxes intended for machine application.

WARNING: To reduce the risk of electrocution, keep all connections dry and off the ground. Do not touch the plug with wet hands.

Extension Cords

Use only 3-wire extension cords that have 3-prong grounding-type plugs and 3-pole cord connectors that accept the plug from the product. Use only extension cords that are intended for extra-hard service.

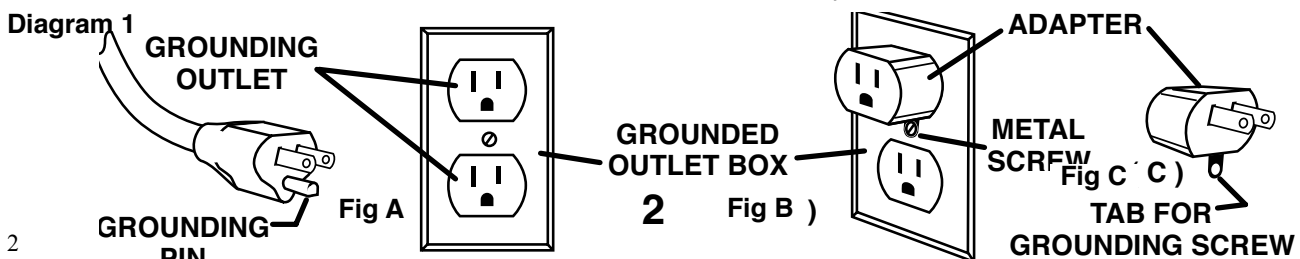

These extension cords are identified by a marking, such as "S, SO, ST, or STO". Use only extension cords having an electrical rating no less than the rating of the product. Do not use damaged extension cords. Examine the extension cord before using, and replace if damaged. Do not damage the extension cord and do not pull on any cord to disconnect. Keep the cord away from heat and sharp edges. Always disconnect the extension cord from the receptacle before disconnecting the product from the extension cord.

BACKER PAD/DUST SKIRT INSTALLATION

1. Use 3/4" open end wrench to hold lower shaft and turn backer pad clockwise to install. (Fig. 2 and Fig. 3)
2. HAND TIGHTEN ONLY!
3. Set machine upright on floor.
4. Attach removable part of dust skirt to lower part of deckplate so that the skirt just touches the floor.

(If not properly installed the vacuum may not operate to its full potential.)

Fig. 2



Fig. 3



PREPARATION INSTRUCTIONS

SAFETY:

Warning:

1. Make sure the Sander is OFF before you plug it in.
2. Never change sand paper while the sander is plugged in. This can cause serious injury.
3. Check breaker circuit to be used, 20 amp. is the minimum required.

4. Always wear eye protection and dust mask while operating the sander.
5. Empty the dust bag in an outdoor area, away from flame or fire.



TOOLS NEEDED:

1. Hammer
2. Pry bar: to remove trim
3. Paint scraper: to scrape corners and hard to reach places
4. Nail set
5. Shop vacuum
6. Plastic draping: to cover and isolate work areas
7. Masking tape
8. Wood filler
9. Mineral spirits or good heavy-duty cleaner

ROOM SETTINGS & FLOOR CHECK:

1. Remove all existing furniture, carpets, floor mats, and curtains from area to be sanded. Sweep the floor thoroughly.
2. Remove all nails, and metal fasteners that protrude from the surface and might damage sanding paper or prevent effective sanding.
3. Check for all cracks and niches and repair damaged areas. Excessive damage may be repaired with wood filler (allow sufficient drying time).
4. Put dust protection on all doorways and heat vents in the form of drop cloths and plastic sheets. Vacuum the room thoroughly.

CHECKING CONDITIONS OF THE FLOOR

Check for condition of floor using the following tests and follow appropriate directions:

Wax Floor:

Place a damp cloth (approx 18" x 18") on the floor. Lift after an hour and check for any cloudy coloration. A white cloudy coloration indicates wax. In this case, strip the wax using a wax stripper before sanding is attempted. Excess wax will clog the sandpaper.

Painted Floor:

Chemically remove paint before attempting to sand floor.

Varnished Floor:

PRO sander will remove most kinds of varnish. Excessive layers of varnish, however, may require chemical removal before attempting to sand the floor.

Unfinished Floor:

Start the sanding process with the least aggressive grit as possible. Progressing to the finer grit paper ranging from 24 (being most aggressive), 36, 40, 60, 80, 100, 120 (being less aggressive), etc.

OPERATING THE PRO - PROFESSIONAL RANDOM ORBITAL SANDER

WARNING: Always remove the electrical plug from the electrical outlet before installing the sandpaper.

Selecting the Paper to Start:

Select the least aggressive grit as possible that removes the desired amount of surface. Too aggressive grits leave swirl marks that are difficult to remove with the finer grits that will be used later. Grits that are not aggressive enough do not take enough of the surface off and result in more work and a slower process (see details in section titled "starting the sanding process").

Installing Paper:

Sanding pads should be installed by leaning the machine back and placing the sandpaper on the backer pads. (Fig. 4)

Changing Sandpaper:

Pads should be changed when worn out or when the floor is ready for the next phase.

Fig. 4



CAUTION: To prevent damage to backer pads, you must change sandpaper when it becomes loaded or clogged.

STARTING THE SANDING PROCESS

WARNING: Before operating the machine, make sure the handle-adjusting lever is tight.



STEP 1:

Determine the condition of the floor. We recommend starting with 36-grit, (24 grit for exterior decks or severely damaged floors). Lean the machine back on the handle, then install the sandpaper to the backer pads. It is recommended to start the sanding process with 36-grit, or 24-grit for poor condition floors. Sandpaper usage will depend on the finish to be removed, and the amount of wood that needs to be removed.

Guide for Sandpaper Needed:

(150 Sq Ft of Floor)

FLOOR IN POOR CONDITION

- 36 Grit 20 Discs
- 40 Grit 20 Discs
- 80 Grit 12 Discs
- 120 Grit 8 Discs

NEW INSTALLATION/FLOORS IN FAIR CONDITION

- 40 Grit 20 Discs
- 80 Grit 12 Discs
- 120 Grit 8 Discs

STEP 2:

With the PRO sander in the upright position, turn the switch on and slowly move the sander over the floor, letting the machine do the work for you. For new installation it is recommended to move the machine across the grain, this is the most effective way to level the floor. (Change sandpaper when paper appears plugged or dull, this may occur after sanding approximately a 10' x 10' area).

Proper Grit Sequence:

- 24 if needed
- 36 for leveling
- 40 sand thoroughly
- 80 final sanding for clear finish
- 120 recommended for staining

STEP 3:

After sanding the floor completely with the first grit, vacuum the floor thoroughly and change paper to the next finer grit. Continue the sanding process. Check paper after sanding about a 10' x 10' area to

see that it is still sanding. Inspect the floor to see if any swirl marks remain. If swirl marks exist, continue to sand just the area with the higher grit paper until they are less visible. You should get down close to the floor and view it from several directions in good light for this inspection.

STEP 4:

Use progressively higher grits. Sand the floor completely. This step will take less time than the previous grits. Periodically check paper to make sure it is clean and effective.

STEP 5:

Inspect the floor thoroughly for scratches or unevenness. Apply the final finishing grit (usually 120 or 180 grit or finer). At this point, the floor should become shiny and free of all swirl marks when inspected closely.

STEP 6:

Corners and edges can be sanded with a detail sander or hand scraper. A paint scraper can be used for hard to reach places, such as under radiators and in corners. Some hand sanding may be necessary in these remote places. Inspect the floor thoroughly to determine when you are finished sanding.

STEP 7:

Vacuum the floor and clean with a tack cloth (available at your local hardware store). Then apply stain or varnish as desired. Follow manufacturer's recommendations for staining and varnishing.

WARNING: Machines can cause flammable materials and vapors to burn. Do not use this machine with or near matches, fuels, grain dust, solvents, thinners, or other flammable materials.

WARNING: To prevent injury always remove the electrical plug from the electrical outlet before changing the sandpaper, emptying the bag, leaving the machine, or doing any maintenance to this machine.

REMOVING THE DUST BAG:

Unlock the Velcro straps and then remove the dust tube from blower. (Fig. 5)

Fig. 5



ADJUSTING THE HANDLE POSITION:

Loosen the black lever and adjust handle position as desired. Tighten the black lever once adjusted. (Fig. 6)

Fig. 6



Handle adjustment knob

PROPER STORAGE OF POWER SUPPLY CORD:

Wrap power supply cord around the frame for storage. Adjust handle to the lowest position and store machine in upright position. (Fig. 6)

CLEANING AND STORAGE:

Empty dust bag and thoroughly shake or vacuum out the bag until empty. Wipe down exterior machine with a damp cloth.

SCHEMATIC AND PARTS LIST

LS-AS Lower Shaft

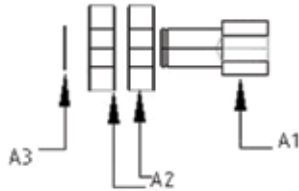

| ref# | order | description |
|------|------------------|-------------|
| A1 | US104-146 | lower shaft |
| A2 | HW-BRG | bearings |
| A3 | HW-ESR | snap ring |

SP-AS-C Spindle Assembly

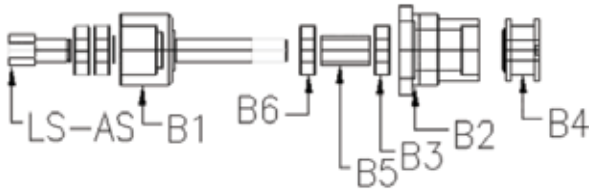

| ref# | order | description |
|-------|--------------------|----------------------------|
| LS-AS | | lower shaft |
| B1 | US103-146C | main shaft |
| B2 | US101-146C | spindle housing |
| B3 | HW-BRG | bearing |
| B4 | US106-146-7 | spindle pulley |
| B5 | US105-146-7 | upper shaft bearing spacer |
| B6 | Bearing-7 | bearing |

BT-AS Belt Tension Assembly

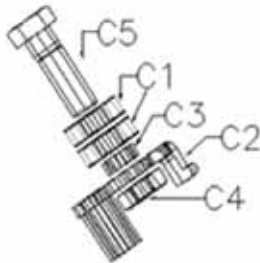

| ref# | order | description |
|------|---------------------|------------------|
| C1 | HW-BRG | bearing |
| C2 | SK-020605-01 | belt tensioner |
| C3 | US-148 | belt tension sub |
| C4 | HW-HCS5/8 | |
| C5 | HW-HN11 | |

HA-AS-C Handle Assembly

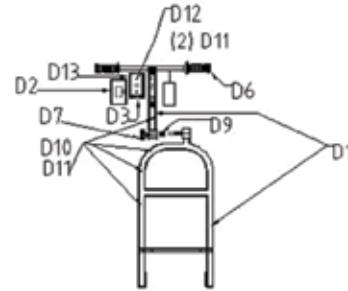

| ref# | order | description |
|------|--------------------------|-----------------------|
| D1 | HAAS1C | handle unit sub |
| D2 | US119-146-7SWITCH | switch |
| | US119-146-7COVER | cover |
| D3 | US120-146-7 | switch box |
| D4 | PC-146C | 43" grey cord |
| D5 | PC-146-MLPC | 17" grey cord |
| D6 | US114-146 | rubber grips (2) |
| D7 | US142-146 | knob for handle pivot |
| D8 | US134-146 | cord restraint (2) |
| D9 | HW-SP1 | 1" spring |
| D10 | HW-1/2 RL Clamp | motor clamp (4) |
| D11 | HW-CS1/4 | cap screws (8) |
| D12 | HW-WN | wire nuts |
| D13 | HW-SPADE | spade for elec box |
| D14 | PC-146-FLP | 25' yellow cord |
| | BB PC L515R | female end 110v |
| | CC PC-L515P | male end 110v |

VB-AS Vacuum Bag Assembly

| ref# | order | description |
|------|---------------|-------------|
| E1 | VB-146 | vacuum bag |
| E2 | VH-146 | vacuum hose |
| E3 | HW-CT | cable tie |

MT-AS Motor Assembly

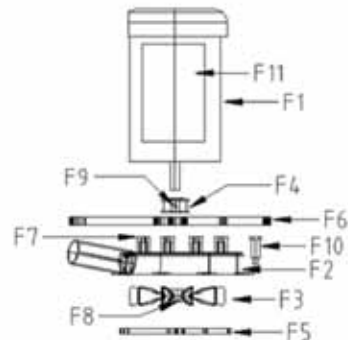

| ref# | order | description |
|------|---------------------------|------------------------------|
| F1 | Motor 1.5HP-C | 1.5 HP motor |
| F2 | US103-146 | fan housing |
| F3 | MT-AS1 | impeller/hub |
| F4 | US116-146 | motor pulley |
| F5 | US-152 | gasket |
| F6 | PCB-146 | belt |
| F7 | HW-CS3/8 | cap screw - blower/motor (4) |
| F8 | HW-CS5/16 | cap screw - impeller |
| F9 | HW-SS | pulley set screw |
| F10 | HW-3/8 Spring Bolt | spring bolt-blower |
| F11 | HW-WN | wire nuts (3) |

WH-ASP Wheel Assembly

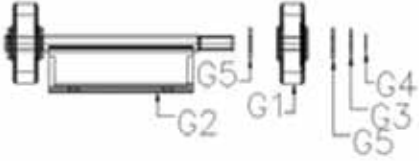

| ref# | order | description |
|------|----------------|------------------------|
| G1 | WH-146P | 3.5" wheel (2) |
| G2 | HWH-AS1 | wheel bracket/axle |
| G3 | HW-WS | wave spring (2) |
| G4 | HW-ESR | external snap ring (2) |
| G5 | HW-W1 | flat washer (4) |

DP-AS-C Deck Plate

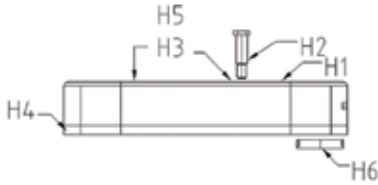

| ref# | order | description |
|------|--------------------|-------------------------|
| H1 | CH101-146-C | base plate |
| H2 | US-150 | belt tension bolt |
| H3 | HW-HCS | hex cap screw (2) |
| H4 | US115-146B | dust skirt attached |
| H5 | HW-LW | lock washer (2) |
| H6 | US102-146-C | spindle housing nut (4) |

US-PRO Sander

| ref# | order | description |
|------|-------------------|------------------------------|
| I1 | US-143 | nuisance tag |
| I2 | US-145C | UL listed tag |
| I3 | LABL-FLAG | American flag |
| I4 | HW-RVT | rivets (6) |
| I5 | US148 | orange safety bag |
| I6 | CH02-146-C | belt cover (1 set, 2 pieces) |
| I7 | HW-CS1/4 | motor clamps cap screws (6) |
| I8 | HW-FW/16 | flat washer (6) |
| I9 | HW-CLN | lock nut-motor |
| I10 | US134-146 | cord restraint |
| I11 | HW-SP3/8 | flat washer (4) |
| I12 | HW-SP3/4 | spring (2) |

WARRANTY

The manufacturer warrants to the original purchaser that products manufactured are free from defects, provided such goods are installed, operated and maintained in accordance with written manuals or other instructions for a period of 1 year from date of purchase on workmanship, motor, and parts. In case you, as our customer, meet any trouble with your machine, contact a Powr-Flite representative, who will be happy to be of service to you and will take care of any warranty issues. This warranty covers normal use and does not cover damage which occurs in shipment or failure resulting from alteration, accident, misuse, abuse, neglect or improper maintenance.

Additional Items Excluded From Warranty Coverage:

Appearance items of the product, knobs, filter, electrical cord, plugs, handle grips, dust skirt, drive belt, sanding pads, wheels, dust bag and dust bag attachment/assembly, or to accessories, mounting kit, seals, or any printed materials.

Powr-Flite[®]
COMMERCIAL FLOOR CARE EQUIPMENT

A Tacony Company

3101 Wichita Court • Ft. Worth, TX 76140-1755

1-800-880-2913 • Fax: 1-817-551-0719 • www.Powr-Flite.com