

# Powr-Zone Ozone Generator

OPERATORS MANUAL AND PARTS LIST

## Model PFPZ



**POWR ZONE**  
Ozone Generator  
by **Powr-Flite**

- 1.5 grams/hr., 7 p.p.m
- Effective for areas up to 60,000 cubic feet
- Gas filled arc module electrodes

### **READ ALL INSTRUCTIONS BEFORE OPERATING**

OZONE IS A POWERFUL OXIDIZER AND MUST BE USED WITH CARE

WARNING: USE IN UNINHABITED AREAS ONLY. Ozone attacks organic matter. Limited exposure can cause nausea. Prolonged exposure, more than 48 hours, can be hazardous. Do not get machine wet. Consult MSDS sheet before use.

WARNING: OPERATOR MUST READ AND UNDERSTAND THIS MANUAL COMPLETELY BEFORE OPERATING THIS EQUIPMENT.

## Powr-Zone – the Professional Odor Neutralizer

Not a simple cover-up or ionizer, the Powr-Zone unit is an economical environmental odor neutralizer that actually destroys the source of the odor and leaves pure, fresh oxygen in its place. This large-capacity ozone generator is ideal for commercial use, eliminating odors in any indoor location and in vehicles. It is excellent for removing odors caused by smoke damage, mold, mildew, pets and other sources commonly encountered in building maintenance and refurbishing. Use the Powr-Zone unit in basements, kitchens, bathrooms, and any room with an odor problem. It also provides rapid deodorizing of hotel/motel rooms, meeting rooms and vehicles such as automobiles, buses, boats and aircraft.

**Your Powr-Zone is complete and ready to operate.**

### SAFETY PRECAUTIONS

Do not operate equipment before reading and understanding all instructions, procedures and warnings.

Do not use this product near water or in a moist environment.

Operate equipment only with the correct electrical power.

Do not attempt to service this product yourself as opening or removing the enclosure may expose you to dangerous voltage or other hazards.

Do not put foreign objects inside the equipment.

Do not operate equipment with a damaged cord or plug, if fans fail to rotate, after the equipment malfunctions or if it has been dropped or damaged in any manner. Return equipment to manufacturer for examinations, electrical or mechanical adjustment or repair.

Do not block air flow through equipment. Set equipment at least 6 inches from walls or any structure that could block the air intake.

Do not use equipment in a flammable or explosive atmosphere.

**OZONE IS A POWERFUL OXIDIZER THAT REACTS WITH ORGANIC SUBSTANCES AND IS CLASSIFIED BY OSHA AND EPA AS AN UPPER RESPIRATORY IRRITANT. OSHA SETS THE ALLOWABLE EXPOSURE LIMITS AT .05 PPM TO .1 PPM. ALL SAFETY PRECAUTIONS HEREIN MUST BE ADHERED TO AND COMMON SENSE PRACTICED.**

The ozone produced by the Powr-Zone is above the allowable exposure limit as set by OSHA for inhabited areas. Therefore, no person or animal should remain in an area being treated by these units. The treated area should be aired out or given enough time for the ozone to dissipate to a level below .1 PPM before people or animals are allowed to re-enter. Ozone has an average half-life of 20 minutes, so one hour should be sufficient time for an un-vented room to return to normal. If ozone odors are noticeable and irritating, the area should be vented longer until the level is reduced. The average person can detect ozone at levels as low as .003 PPM.



Symptoms of prolonged or excessive exposure to ozone are: burning, watery or irritated eyes, nose, and throat, nausea, headache, difficult in breathing, dry cough, irritation to nasal passages, throat, bronchial and pulmonary membranes.

### Caution:

Prolonged exposure can also affect certain organic materials such as rubber, plastic, wire insulation.

Only qualified personnel should operate the Powr-Zone ozone generator.

As with all electrical devices this equipment should not be operated in a wet or damp environment.

This equipment should only be operated using a properly grounded electrical outlet.

All precautions must be taken to prevent over exposure of ozone gas to occupied areas.

Do not disassemble your Powr-Zone equipment, there are no user serviceable items inside and this will also void the warranty.

Powr-Flite assumes no liability for damages or injuries incurred by the misuse of this equipment.

**GENERAL INSTRUCTIONS**

Prior to using the Powr-Zone ozone generator, determine the source of the odor and remove any odor causing substance that can be found. If the odor is from a wet or flooded situation, dry the entire area well before starting the ozonation procedure.

1. Make certain all people, pets and plants are out of the area. Close all windows and doors. Place a safety sign on the door to the location warning of Ozone use – *DO NOT ENTER*.
2. Place the Powr-Zone unit on a shelf or tabletop as high in the area to be treated and if possible, near the AC return.

**NOTE:** Ozone is heavier than air and will fall to the bottom of the room. For best results place an air mover at a 45° angle, pointed towards the wall to create a circular air movement.

3. Set the air conditioning thermostat on constant fan and adjust the temperature control to a low (cold) setting. If AC is not available, use air movers for more effective treatment.

**NOTE:** Ozone generators work best in a cool, low humidity environment. With the AC on, you also receive a secondary benefit of purifying the inside of the ductwork. This is also true for ozoning automobiles. Smoke and stale odors will stay in a car's AC ducts if you do not run the AC during ozoning.

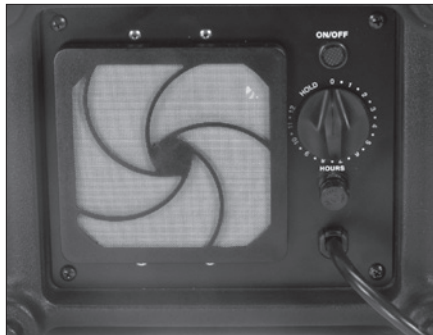

4. Plug the power cord into a grounded, 3-prong outlet.
5. To set the timer, turn the dial to "12" and then back to desired length of time.
6. Leave the area immediately. Do not return until set time plus 20 minutes has expired.
7. After time has expired, open all windows or doors to air out for 20 minutes.

To calculate the time to remove the odor or to purify an area:

$$(x \text{ cubic feet} \div 100 \text{ CFM}) \times 2 = \text{time setting}$$

*example:*

$$(1000 \text{ cubic foot room} \div 100) \times 2 = \text{time setting}$$

$$10 \times 2 = \text{time setting}$$

$$20 \text{ minutes} = \text{time setting}$$

**NOTE:** Ozone destroys odor-causing molecules. The length of time this process takes will vary depending on variables such as pollutant load, temperature, humidity, etc. and the amount of area being treated. The ozone process can produce a haze in the air within the area being treated.

**CAUTION**

DO NOT BREATHE HIGH LEVELS OF OZONE. OZONE IN CONCENTRATIONS ABOVE 0.04 PPM IS CLASSIFIED AS AN UPPER RESPIRATOR IRRITANT AND MAY BE CONSIDERED UNHEALTHY IN OCCUPIED AREAS. THIS MODEL OZONE GENERATOR IS INTENDED FOR USE IN UNOCCUPIED AREAS ONLY. THIS OZONE GENERATOR SHOULD BE TIMED TO TURN OFF AT LEAST 20 MINUTES PRIOR TO REENTRY OF TREATED AREA. TREATED AREA SHOULD BE AIRED OUT PRIOR TO REENTERING TO PREVENT EXPOSURE TO HIGH LEVELS OF OZONE.

**TROUBLESHOOTING**

Problem	Possible Cause	Solution
Unit does not turn on	Power cord not plugged in.	Plug power cord into suitable outlet with correct voltage.
	Circuit breaker is tripped.	Reset circuit breaker at panel box.
	Faulty power outlet.	Try another outlet.
	Fuse is blown on back of unit	Replace fuse.
Unit keeps blowing Fuses.	Too small amperage fuse is being used	Replace fuse with correct rated (1A) fuse.
	Electrical short circuit.	Return unit to manufacturer for repair.
Unit does not produce ozone.	Damage to unit.	Return unit to manufacturer for repair.

# MATERIAL SAFETY DATA SHEET (MSDS)

24 HOUR EMERGENCY PHONE: 1-800-424-9300

Name: OZONE  
Product: Triatomic Oxygen  
Issued: 12/01/00

Not Available at  
Date Issued

NFPA HAZARD RATING  
4 = EXTREME 3 = HIGH  
2 = MODERATE 1 = SLIGHT  
0 = INSIGNIFICANT

## SECTION 1 - IDENTIFICATION

Chemical Name: Triatomic Oxygen  
Chemical Family: Gas  
DOT Hazard Class: N/A  
DOT Identification: N/A

## SECTION 2- HAZARDOUS INFORMATION

Component	CAS #	%	PEL	TLV
Ozone Gas	10028-15-6			0.1ppm

## SECTION 3- PHYSICAL DATA

Appearance and Odor: Colorless gas, pungent odor.  
Minimum detectable odor at  
0.02 ppm.

Boiling Point: 112° C  
Vapor Pressure: N/A  
Vapor Density (air +1): N/A  
Solubility, v in Water: N/A  
Specific Gravity (H<sub>2</sub>O = 1): 1.6 g/l (liquid)  
Melting Point: 192° C  
Evaporation Rate (H<sub>2</sub>O=1): N/A

## SECTION 4 - FIRE & EXPLOSION DATA

Not flammable, but enhances combustion of other substances to cause fire or explosion.

Flash Point: N/A  
Flammable Limits: N/A  
LEL: N/A  
UEL: N/A  
Fire Extinguishing Media: Use the extinguisher appropriate to burning material.  
Special Firefighting Procedures: None  
Unusual Fire Hazards: Increased oxygen can feed fire.  
Explosion Hazards: None

## SECTION 5 - REACTIVITY DATA

Stability: Unstable. Begins to dissipate immediately.  
Conditions to Avoid: N/A  
Incompatibility: High levels for extended periods will cause deterioration of rubbers, paint and metal.  
Hazardous Decomposition: N/A  
Hazardous Polymerization: None

Disclaimer: The information in this document applies to work-place exposure and is not designed for the population at large. Any generalization beyond occupational exposures should not be made.

## SECTION 6 - HEALTH HAZARD DATA

Health Hazards: Irritation of the eyes and respiratory tract. Inhalation of the gas may cause lung edema or asthmatic reactions. Symptoms may not become noticeable for several hours. Lungs may be affected by repeat or prolonged exposure.  
None known.

Carcinogenicity: None known.  
Medical Conditions: None known.  
Aggravated by Exposure: N/A  
Methods of Exposure: Inhalation and contact on skin and eyes.  
Symptoms of Exposure: Cough, dry throat, irritated eyes, headache. Possible asthma-like symptoms with overexposure.

## EMERGENCY FIRST AID:

Eye and Skin: Move to fresh air.  
Inhalation: Move to fresh air. Seek medical attention if asthma-like symptoms are noticed.  
Ingestion: N/A

## SECTION 7 - PRECAUTIONS FOR SAFE HANDLING & USE

Storage and Handling: N/A  
Spill Response: N/A  
Waste Disposal: N/A  
Other Precautions: EPA Recommended Exposure Limits: 0.1 ppm / 8 hrs or maximum 0.3 ppm for 10 mins.

NOTE: Threshold limit values refer to airborne concentrations of ozone and represent conditions under which it is believed that nearly all workers may repeatedly be exposed day after day without adverse effect, however a small percentage of workers may experience discomfort at levels below those listed.

## SECTION 8 - CONTROL MEASURES

This gas is designed to be used for a limited time in a controlled environment.

Eye Protection: None  
Ventilation: When treatment is complete, ventilate the area completely until all smell of ozone is gone. Do not allow people or pets into the area until the ozone smell is eliminated.  
Respiratory Protection: Do not use in inhabited spaces. Clear all people, animals, plants and any other organic life from the area to be treated.

Protective Clothing or Other Equipment: None  
Work/Hygienic Practices: N/A

**Power-Flite**  
**COMMERCIAL FLOOR CARE EQUIPMENT**

A Tacony Company

3101 Wichita Court • Ft. Worth, TX 76140-1755

# Powr-Zone

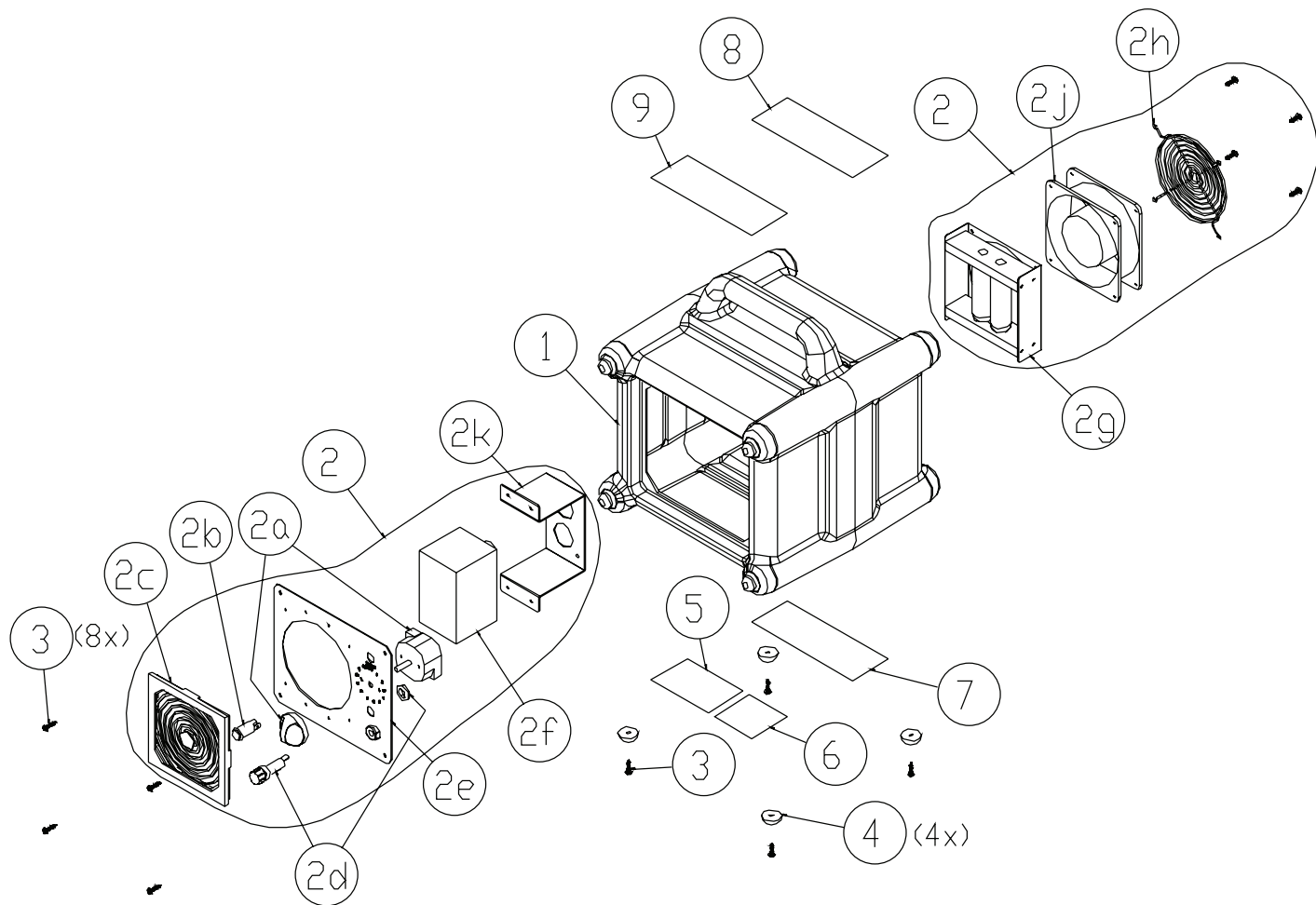

ref #	part no	description
1	X9227	Housing
2	X9229	Kit, Component
2a	X9248	Timer
2b	X9247	Lamp, On/Off Indicator
2c	X9246	Filter, Intake
2d	X9249	Fuse Holder
2e	X9228	Panel, Switch
2f	X9242	Transformer
2g	X9241	Ozone Tube w/ Cables
2h	X9245	Grill, Fan
2j	X9244	Fan
2k	X9243	Bracket, Transformer

ref #	part no	description
3	72387A	Screw, #8 x 5/8, Black Tapping
4	PD3C	Foot, Black Rubber
5	X9235	Label, Time Chart
6	X8459A	Label, Serial Number
7	X9232	Label, Caution
8	X9231	Label, Instruction
9	X9230	Label, Powr-Zone

#### 220V Powr-Zone Parts

2	X9229-2	Kit, Component 220V
	X9597	Euro Plug

## Conditional Guarantee

The manufacturer warrants that products manufactured are free from defects in material and workmanship under normal use and service for a period of one year from date of purchase provided such goods are installed, operated and maintained in accordance with written manuals and/or other instructions. We will repair or replace without cost, any part of the unit, which when examined by our authorized repair station or at our factory, is found to be legitimately defective.

This guarantee is null and void on any part which has been subject to alteration, accident, abuse or misuse. The guarantee is valid only to the original using purchaser.



A Tacony Company  
3101 Wichita Court • Ft. Worth, TX 76140-1755