

Power-Flite[®]

COMMERCIAL FLOOR CARE EQUIPMENT

Model Commercial Spotter stock number PS25



Save These Instructions

IMPORTANT SAFETY INSTRUCTIONS

*When using a commercial spotter, basic precautions should be followed, including the following: *Read all instructions before using this commercial spotter.

SAVE THESE INSTRUCTIONS FOR FUTURE REFERENCE

WARNING

To reduce risk of fire, electric shock, or injury:

- Do not use outdoors or on wet surfaces.
- Do not leave commercial spotter unattended when plugged in. Turn off the switch and unplug the electrical cord when not in use and before servicing.
- Do not allow to be used as a toy. Close attention is necessary when used near children.
- Use only as described in this manual . Use only manufacturer's recommended attachments.
- Do not use with damaged cord or plug. If commercial spotter is not working as it should, has been dropped damaged, left outdoors, or dropped into water, return it to a service center before using.
- Do not pull or carry by cord, use cord as a handle, close a door on cord, or pull a cord around sharp edges or corners. Do not run commercial spotter over cord. Keep cord away from heated surfaces.
- Do not use extension cords or outlets with inadequate current carrying capacity.
- Turn off all controls before unplugging.
- Do not handle plug or commercial spotter with wet hands.
- Do not put any objects into openings. Do not use with any opening blocked, keep free of dust, lint, hair, and anything that may reduce airflow.
- Keep hair, loose clothing, fingers, and all parts of body away from openings and moving parts.
- Do not pick up anything that is burning or smoking, such as cigarettes, matches or hot ashes. Use extra care when cleaning on stairs. Do not use to pick up flammable or combustible liquids such as gasoline, or use in areas where they may be present.
- Store your cleaner indoors in a cool, dry area.
- Do not unplug by pulling on cord. To unplug, grasp the plug, NOT THE CORD.

THESE MODELS ARE GROUNDED, CONNECT TO A PROPERLY GROUNDED OUTLET ONLY - SEE GROUNDING INSTRUCTIONS.

GROUNDING INSTRUCTIONS

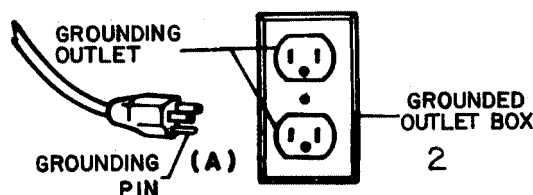

This appliance must be grounded. If it should malfunction or breakdown, grounding provides a path of least resistance for electric current to reduce the risk of shock. This appliance is equipped with a cord having an equipment-grounding conductor and grounding plug. The plug must be inserted into an appropriate outlet that is properly installed and grounded in accordance with all local codes and ordinances.

WARNING - Improper connection of the equipment-grounding conductor can result in a risk of electric shock. Check with a qualified electrician or service person if you are in doubt as to whether the outlet is properly grounded. Do not modify the plug provided with the appliance - if will not fit the outlet, have a proper outlet installed by a qualified electrician.

This appliance is for use on a normal 120 volt circuit, and has a grounded plug that looks like the plug illustrated in sketch A.

Note: In Canada, the use of a temporary adapter is not permitted by the Canadian Electrical Code.

Operating Instructions for EX3S Spotter

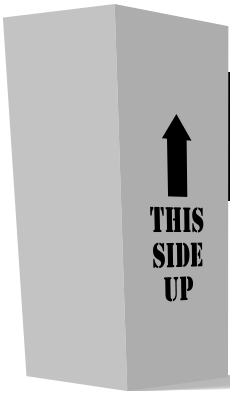

WHEN THE MACHINE IS DELIVERED...

Check the carton carefully for signs of rough handling. Remove the machine from the carton. If the machine is damaged, notify the carrier immediately and request an inspection. Be sure to

keep the carton, packing inserts, packing lists and carrier receipt until the inspector has verified your claim.

Liability ceases when the shipment is picked up by the carrier, but our customer service staff will be glad to furnish any information needed in connection with the claim and will expedite the repair of the machine.

STOP

BEFORE USING THE MACHINE

Read the manual carefully and completely before attempting to operate the unit. This manual has important information for the use and safe operation of this machine. Keep this manual handy at all times. The carpet spotter will assure years of satisfactory service if operated and maintained according to recommendations in the manual.

PROMISE

WARRANTY

To protect your investment, promptly fill in the required information on the warranty card included with the unit. Then mail the card back.

CAUTION

GENERAL PRECAUTIONS

Follow these guidelines to ensure operator safety and to maintain equipment in running order.

- Make sure the machine is plugged into an electrical outlet with the same voltage rating as shown on the nameplate of the machine.

Do not attempt to plug a 115 volt machine into a 230 volt outlet or a 230 volt machine into a 115 volt outlet.

- Disconnect the power cord from the outlet before attempting maintenance or repair work.
- Do not leave machine connected to an electrical outlet when unattended.
- Never pull the machine by the cord or yank the cord from the receptacle. Replace a damaged cord immediately.
- If an extension cord is necessary, use a three conductor grounding cord – 12 gauge wire or heavier to prevent motor burnout and over-heating of wires.
- To avoid electric shock, do not expose to rain. Store indoors.
- To avoid fire, do not use machine in environments where combustible liquids, vapors or dust concentrations are present.



WARNING

- Do not expose the machine to freezing temperatures.
- Do not use the machine for totally dry vacuuming. This machine is not fitted with a fine dust filter.
- **Do not use citrus-based cleaners in this machine.**
- Do not use cleaning chemicals in this machine except those recommended for commercial extraction equipment. **The use of any chemical with abrasive additives voids the warranty.**
- Do not break off or pull out the ground prong on the plug
- Do not attempt repair on a warranted machine unless instructions to perform it by an authorized shop are obtained from the factory.
- Do not use any replacement parts except those specified on the parts list. Proper performance of the machine could be affected if substitutions are made.
- Use defoamer at all times to prevent damaging the vacuum motor.
- Do not use water in excess of 140° F (62° C).
- Follow maintenance schedule strictly.

Failure to comply with the above warning instructions will void the warranty.

Filling the Spotter

Add water and chemicals to the solution tank in the front of the machine.



Operating the Spotter

A. Attach the solution feed line to the quick disconnect at the top of the machine.

B. Attach the vacuum hose to the vacuum inlet on the recovery tank lid.

C. Turn the 3-way switch to use either the pump and vacuum or the vacuum alone.
(Allow approximately 30 seconds for the pump to prime.)

D. Use the hand tool to spray and recover the solution.

E. The float shut-off will disable the suction of the unit when the recovery tank is full. The operator will notice a distinctive change in the sound of the vacuum motor when the shut-off is activated. Empty the recovery tank to resume cleaning.



Cleaning the Recovery Tank

A. To drain the tank, remove the plug at the back of the machine and tilt on wheels with the handle.

B. Make sure the foam filter at the top of the recovery tank is clean and dry.

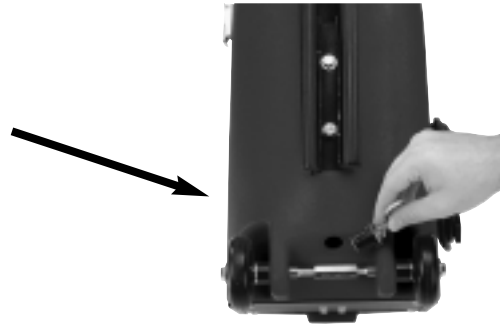

Basic Troubleshooting:

A. If the pump does not prime, depress the lever on the hand tool to release the air lock.

B. If solution flow is reduced or spray is weak:

1. Check for low solution level in the solution tank.
2. Check the screen on the hose in the solution tank for blockage.
3. Check the spray jet from the hand tool for blockage.

If suction is low:

1. Check the recovery tank to see if it is full.
2. Check the foam filter at the top of the recovery tank for debris.
3. Check for blockage in the hand tool or the hose.
4. Add defoamer to recovery tank

Parts Diagram

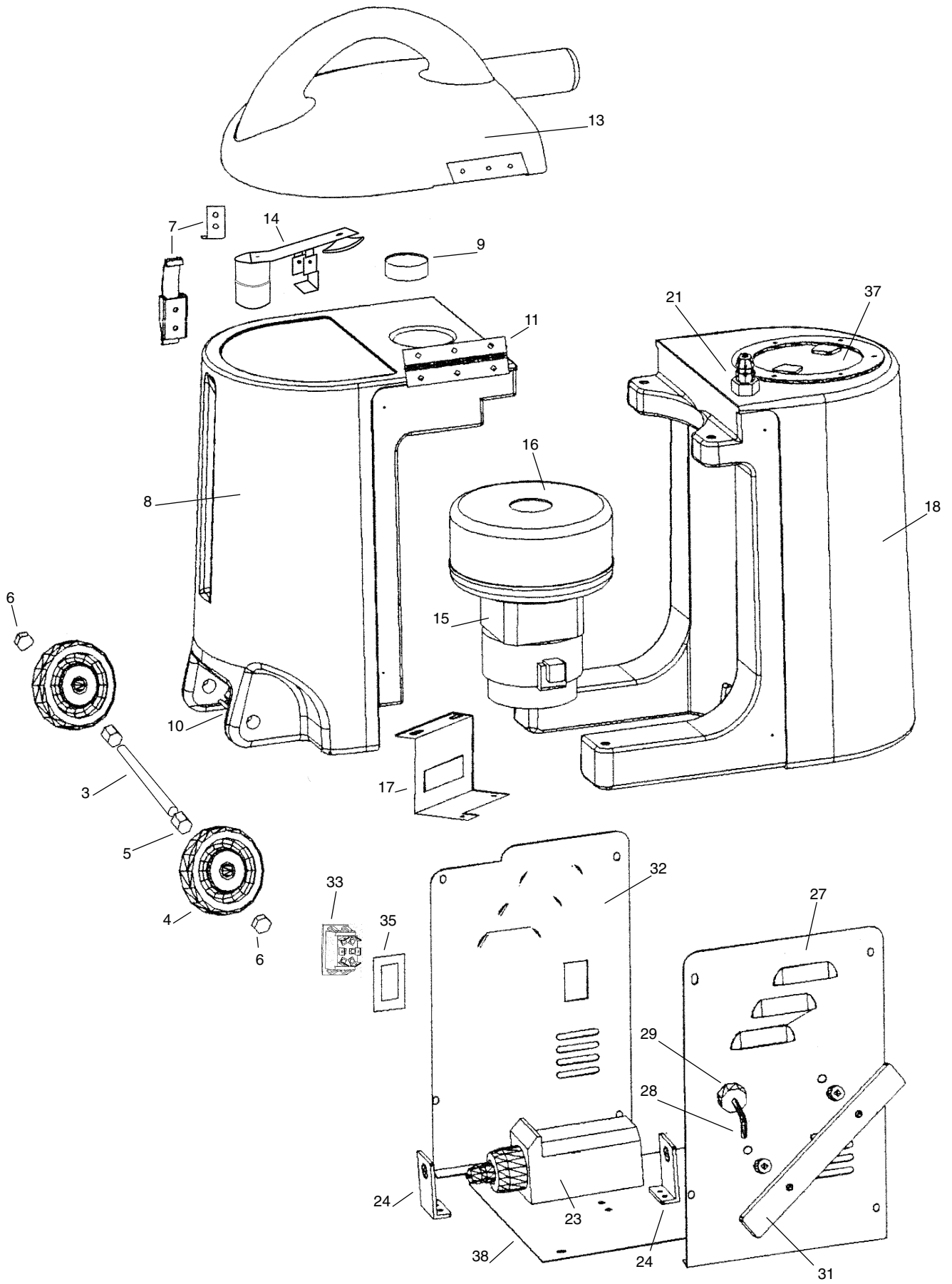

Parts List

ref. #	order #	description
3	PX211	Axle
4	PX206	Wheel
5	X8293	Spacer, Wheel
6	PX118B	Pal Nut
7	PX207	Latch
8	PX202S	Recovery Tank, w/screen, Spotter
9	PX209	Foam Filter
10	PX210	Drain Plug
11	PX40A	Hinge
12	PX203G	Gasket, Housing Lid
13	PX203G	Lid, Recovery Tank
14	PX144S	Flapper/float Assembly
15	1987	Motor, Vacuum
16	PX13	Gasket, Motor
17	PX99	Bracket, Motor
18	PX201	Solution Tank
21	PC10	Fitting, Brass, 1/8 FPT X 1/8" MQD
23	FJ5082	Pump, Oscillating
24	PX204	Mount, Pump (pair)
27	PX142	Panel, Cord Access
28	M1408	Cord, 18/3, 15'
29	PD8	Strain Relief, 1/2" NPT
31	PX205	Plate, Cord Wrap
32	PX141	Panel, Switch
33	PX87A	Switch, Rocker, on/off/on
34	PX48G	Gasket, Bulkhead
35	X8497A	Label, Switch
37	PX103A	Lid, Solution Tank
38	PX143	Panel, Bottom

Not Shown

PX146	Handle
PX147	Handle Support
PX30	Strainer, Solution Tank
X8548	Hose, 1/4" ID (by the foot)
PX212	Fitting, Brass, 1/4 MPT X 1/4" HB, 90 Deg. Elbow
PX48	Fitting, Brass, Bulkhead, 3/4"
PX214	Fitting, Nylon, 1/8" MPT X 1/4" HB, 90 Deg. Elbow
X8008N	Nut, Strain Relief
PX103AG	Gasket, Solution Tank Lid
1507WDS	Hose Assembly, 1-1/4" X 10'
X8860	Hand Tool
PX215	Clamp, Hose, 2-1/4", SS
X8294	Spacer, Cord Wrap



3101 Wichita Court • Fort Worth, Texas 76140-1710
Call Toll-Free (800) 880-2913 • Fax (817) 551-0719