



Upright Extractor

OPERATORS MANUAL AND PARTS LIST

Model PFX1300 SERIES



WARNING: OPERATOR MUST READ AND UNDERSTAND THIS MANUAL COMPLETELY BEFORE OPERATING THIS EQUIPMENT.

IMPORTANT SAFETY PRECAUTIONS

WARNING! To reduce the risk of fire, electric shock, or injury

WARNING
To avoid fire, DO NOT use with a flammable or combustible liquid to clean floor.



WARNING
To avoid electric shock, DO NOT expose to rain. Store Indoors.

When using this self extractor, basic precautions should always be followed, including the following:

- 1) DO NOT leave unit when plugged in. Unplug from outlet when not in use and before servicing.
- 2) DO NOT allow unit to be used as a toy. Close attention is necessary when used around or near children.
- 3) Use only as described in this manual. Use only manufacturer's recommended attachments.
- 4) DO NOT use with damaged cord or plug. If unit is not working properly because it has been dropped, dropped into water, left outdoors, or damaged in any way, contact a service center of Powr-Flite.
- 5) DO NOT handle plug or appliance with wet hands.
- 6) DO NOT put any objects into openings. DO NOT use with any opening blocked: keep free of dust, lint, hair, or anything that may reduce air flow.
- 7) Keep hair, loose clothing, fingers, and all parts of body away from openings and moving parts.
- 8) DO NOT pick up anything that is smoking or burning such as cigarettes, matches, or hot ashes.
- 9) DO NOT use to pick up hazardous chemicals.
- 10) Turn off all controls before unplugging.
- 11) Turn unit off immediately if foam or liquid comes from machine exhaust. Empty & clean out recovery (dirty) tank and use defoamer to correct the problem.
- 12) DO NOT use to pick up flammable or combustible liquids such as gasoline or use in areas where they may be present.
- 13) DO NOT use where oxygen or anesthetics are used.
- 14) Replace damaged or worn parts immediately with genuine original equipment parts to maintain safety.
- 15) This unit must be connected to a properly grounded outlet only. See grounding instruction on page 4.

GROUNDING INSTRUCTIONS

DANGER: Improper use of the grounding plug can result in a risk of electric shock.

GROUNDING INSTRUCTIONS

This extractor must be properly grounded. If it should malfunction or break-down, grounding provides a path of least resistance for electrical current to reduce the risk of electric shock. This machine is equipped with 1 or 2 pig-tail cords having an equipment-grounding conductor and grounding plug. The pigtails must be inserted into an appropriate 12 gauge extension cord

GROUNDING METHODS

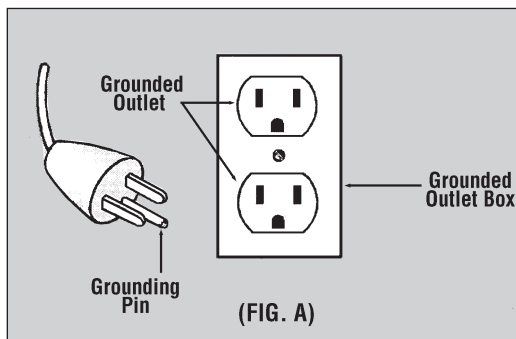

This unit is for use on a nominal 120 volt circuit and has a grounded plug that looks like the plug illustrated in (Fig. A).

WARNING!

Improper connection of the equipment-grounding conductor can result in a risk of electric shock. Check with a qualified electrician or service person if you are in doubt as to whether the outlet is properly grounded. **DO NOT** modify the plug provided with the appliance. If it will not fit the outlet, have a proper outlet installed by a qualified electrician.

General instructions for PFX1300 series Extractors

Congratulations on your purchase of a Powr-Flite extractor. You are now equipped to handle any and all commercial carpet cleaning jobs. Your new extractor is outfitted with a 1750-watt in-line heater (PFX1300H, PFX1300HP & PFX1300HDX models). The water heats up as it passes through the heater to a high water temperature. To obtain and maintain maximum heat levels start out with the hottest tap water you can get (120-135 degrees). This will also ensure a faster start up time (60-90 sec.). Follow these easy step by step instructions to insure proper operating performance.

Shipping and Damage

This equipment is thoroughly inspected, tested, and packaged to provide equipment in good operating condition. It is beyond our control after the equipment is turned over to a freight carrier. The freight carrier received and signed for the equipment in good condition. Consequently, it is most important to protect your interest by carefully complying with the following instructions:

Please inspect your cartons for any damage (including concealed damage) that might have occurred during shipment. Any damage is the responsibility of the freight carrier and should be reported to the freight carrier immediately. It is your responsibility to issue a claim and to receive compensation from the freight carrier for any damage done in transit. Damage of this sort is not warranted.

Follow these easy step by step instructions to ensure proper operating performance.

1. Fill up the fresh water solution tank with tap water that is 120-135 degrees and approved carpet cleaning chemical if you are not pre-spraying your chemical on the carpet.
2. Attach two 12 gauge extension cords (NOT INCLUDED) (one cord for non-heated models) to each of the pigtail cords located on the lower backside of the unit. The red pigtail powers the heater while the black pigtail powers the vacuummotors and pump.
3. Plug each extension cord into a separate and grounded 20 amp wall socket, when this is accomplished the green indicator light will be lit (on heated models).
4. Attach the hose system to the unit and to your carpet wand.
5. Turn on the heater and the pump to the "on" position, (only pump on non-heated models) when the heater is on the orange indicator light on the switch panel will be lit.
6. With the solution line attached to the wand and the machine, prime the pump by squeezing the trigger on the wand releasing the water (hold wand tip over solution tank to put water back into solution tank). This will pump water into the heater and get any air out of the solution line. Let the heater heat up this will take 3 to 5 minutes.
7. Turn vacuum switches to the "on" position and begin cleaning.
8. Anyone designated to operate this equipment must, without fail, read and thoroughly understand all instructions and precautions prior to use.
9. Never use equipment out of doors or in the rain.
10. Never use flammable or explosive materials in or around this equipment!!!
11. When vacuum tank is full, empty by using drain valve at front of machine. If a pail is used to empty the vacuum waste tank, do not use the same pail to fill the solution tank as this can result in putting dirt and grit into the solution line that can plug filters, orifices, and generally degrade the solution line system. (do not reuse solution)
12. To empty solution tank, detach the wand from the end of the vacuum hose and insert the vacuum hose into the solution tank. Turn the vacuum switch to "on" position and transfer solution to vacuum tank and dispose of as outlined in #12. Clean vacuum stack filter at this time.

Maintenance

To receive reliable service from this equipment, regular daily maintenance is a requirement. Fabric cleaning, both carpet and upholstery, are very dirty environments for any equipment. The following recommendations are offered.

1. Keep the equipment clean, both inside and out.
2. Lubricate brass quick disconnects and drain valves with a quality lubricant such as WD-40.
3. Flush solution systems weekly after daily use preventive maintenance with clear, clean water. (A white vinegar solution may also be used). This will counter-act hard water and alkaline deposits and aid in keeping orifices clean.
4. Do not allow fluid either in solution or waste tank to sit overnight. The unit should be emptied and cleaned daily.
5. Clean the strainer in the solution tank, the filter on vacuum stack in vacuum tank and the lint filter in the inlet or vacuum tanks daily.
6. Do not use the same receptacle (bucket) to fill solution tank that is used to remove waste from vacuum tank.
7. When the unit is not in use, leave the vacuum tank lid open.
8. At the end of each day, run the vacuum for 3 minutes with lid open and filter off.

Safety Precautions

These precautions are designed with the safety of the operator, the equipment, and others in mind and must be followed at all times to avoid serious personal harm and/or death, and damage to the unit.

1. Always use a grounded electrical outlet.

2. Always disconnect electric cable from electrical outlet before attempting to make any adjustments or repairs.
3. Never use this equipment as a toy.
4. Never use equipment near or around flammable or explosive materials, fuels, or solvents.
5. Never put flammable materials, fuels, or solvents into equipment.
6. Never lift the machine by the drain valve.
7. Do not allow the unit to freeze!
8. The equipment was not designed to be used outdoors or in the rain.
9. Do not operate in standing water.
10. Wear safety equipment and clothing to protect from extremely hot water.
11. Do not operate equipment under any unsafe condition.



12. Do not operate if pigtails, hoses, etc. are cracked, frayed, leaking, or otherwise in need of repair.
13. Common sense is a powerful force in protecting the operator, the equipment and others from serious damage injury and/or death.

Storage of Equipment

1. Store extractor indoors in dry area.
2. Recovery and solution tank should be empty and clean when the extractor is not in use.
3. Leave the recovery lid and dump valve open to air out the recovery tank.
4. Do not store in freezing temperature.
5. A small amount of windshield washer fluid available at an auto supply may be left in the pump and internal solution line for protection against freezing.

Warnings

1. Do not break off or pull the grounding prong on the plug.
2. Do not attempt repair on a warranted machine unless instructions to perform it by an authorized shop are obtained from the factory.
3. Do not use citrus-based (D-Limonene) cleaners in this machine.

4. Do not use cleaning chemicals in this machine except those recommended for steam-type extraction equipment. The use of any chemicals with abrasive additives voids the warranty.
5. Do not use any replacement parts except those specified on the parts list. Performance of the machine could be affected if substitutions are made.
6. Do not use water in excess of 140° F (62° C) through the pump system. It could damage the seals and polypropylene casing of the diaphragm pump.
7. Follow maintenance schedule strictly.
8. Failure to comply with the above warnings instructions will void the warranty.



ONE LAST REMINDER

Read All Instructions, Warning and Cautions Before Using. These guidelines are presented for your protection and convenience. Please read them carefully, since failure to heed these precautions could result in discomfort or injury. When using an electrical appliance, basic safety precautions should always be followed.

WARNING

TO AVOID FIRE, DO NOT USE WITH A FLAMMABLE OR COMBUSTIBLE LIQUID TO CLEAN FLOOR.

MODEL PFX1300 SERIES CARPET EXTRACTOR PARTS

PFX1300 motor assembly

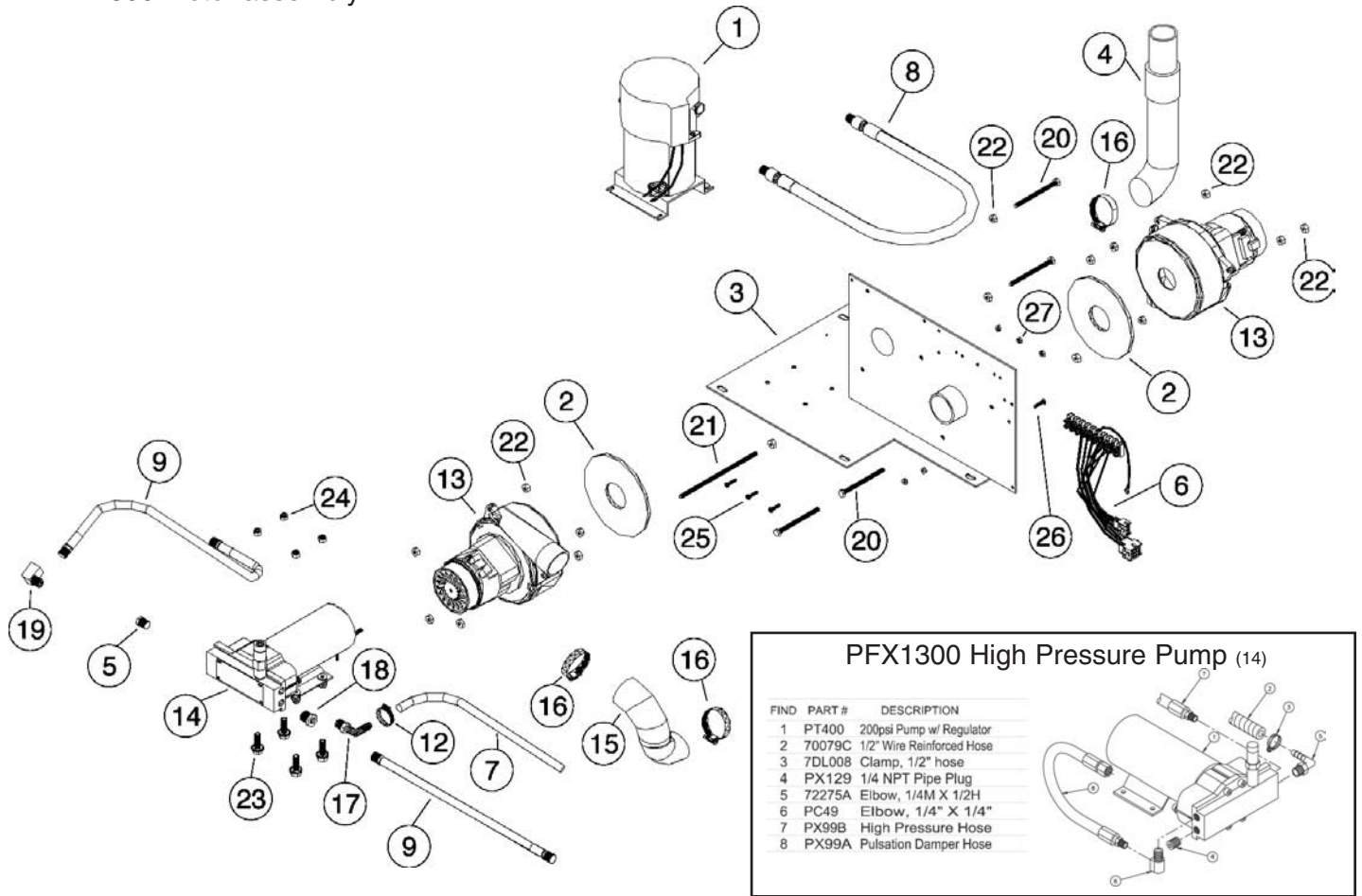

PFX1300 High Pressure Pump (14)

FIND	PART #	DESCRIPTION
1	PT400	200psi Pump w/ Regulator
2	70079C	1/2" Wire Reinforced Hose
3	7DL008	Clamp, 1/2" hose
4	PX129	1/4 NPT Pipe Plug
5	72275A	Elbow, 1/4M X 1/2H
6	PC49	Elbow, 1/4" X 1/4"
7	PX99B	High Pressure Hose
8	PX99A	Pulsation Damper Hose

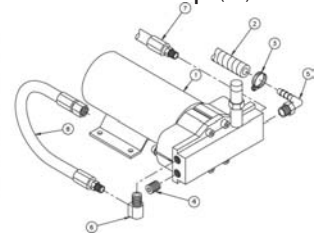

ref#	order	description
1	PF1750	inline heaterfor PFX1300H, HP, HDX
2	PX13	gasket, foam, 5.5" od x 1.75"
3	PX98	mounting plate, motor/pump/htr
4	J1003GC	vac hose s-a
5	PX129	1/4" npt pipe plug pfx1300
6	PX135	pigtail, pfx1300hp
7	PX23G	27" solution hose with no ends
8	PX99A	36" heat pulse hose w/mnpt&
9	PX99B	hose, high pressure/temp, 18"x
10	X8284	8-32 x 3/8" phph, type f
11	X8259	washer, flat #8
12	PX42	clamp 5/8"
13	1942	lamb 6474-37 hrn 2st b/b 9.9a
	1942-IE	motor, vac for PFX1300E
14	SF814	Shurflo pump 100 psi for PFX1300, H
	FJ2030X	Flo-jet pump 100 psi for PFX1300E

ref#	order	description
14	PT400	200 psi pumpfor PFX1300HP
	PT403	400 psi pump for PFX1300HDX, DX
15	J1003GC	hose, flexible, 2" id x 14"
16	PX215	clamp, hose, 2-1/2", ss
17	PX85	fitting, 1/4" mnpt x 3/8" hose
18	PC20	reducer 3/8" to 1/4"
19	PC49	1/4" 90 elbow
20	X8233	bolt, hex, 1/4-20 x 3-1/2"
21	X8289	1/4-20 x 6-1/2" all thread
22	X8213	nut, hex, 1/4-20
23	X8211S	1/4-20 x 1" serrated hex self
24	X8237	nut, 1/4-20, lock, nylon insrt
25	X8287	8-32 x 5/8" phph machine screw
26	X8298	8-32 x 3/4" phph
27	X8256	8-32 keep nut

MODEL PFX1300 SERIES CARPET EXTRACTOR PARTS

PFX1300 upper housing assembly

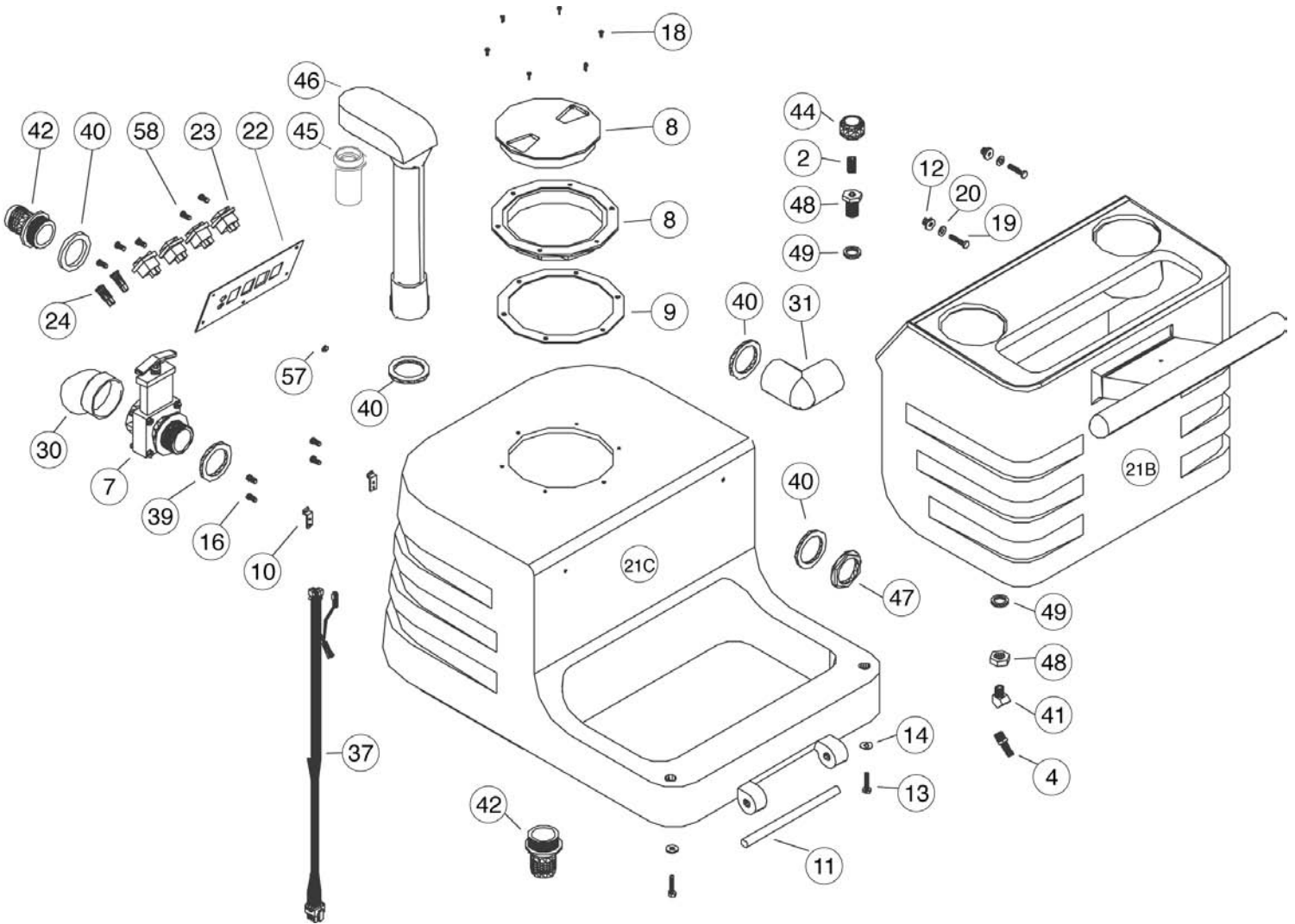

ref#	order	description
1	PC38	connector double thread female
2	PX32	fitting, brass, close nipple,
3	PX42	clamp 5/8"
4	PX85	fitting, 1/4" mnpt x 3/8" hose
5	71511A	bard 1/2"H-1/2" FPT for PFX1300HP, HDX, DX
6	PX112	pigtail, blk, pfx1300
7	PX112R	sub, pigtail, red, pfx1300h/hp
8	PX103	valve, drain, 1-1/2", model #
9	PX103G	lid, screw-in
10	PX103G	gasket, lid
11	PX104	latch assembly
12	PX109	pin, hinge
13	PX88	grommet, 1/4"
14	X8226	1/4-20 x 1-1/4 hex head cap screw
15	X8235A	washer, flat
16	X8238	screw, 6-32 x 3/8"
17	X8253	screw, 6-32 x 1"
18	X8257	nut, lock w/nylon insert
19	X8278	8-32 x 1/2" phph, blacj oxide
20	X8282	1/4-20 x 1" hex head cap screw
21a	X8283	washer, flat 1/4" s/s
21a	PX100	housing, base, black, pfx1300
21b	PX101	housing, solution tank, black,
21c	PX102	housing, recovery tank, blue,
22	PX105H	switch panel

ref#	order	description
23	PX87	switch, rocker, w/protective cover
24	X8102	neon light with lens
25	PX86	indicator light green
26	PX106A	wheel, 10" w/3/4" bore
27	PX106B	wheel, 12 for PFX1300HDX, DX
28	PX107	axle, 3/4" od, pfx1300
29	PX108	bracket, axle, pfx1300
30	PX110G	grill, fan, pfx1300
31	PX11	fitting, plastic, elbow, blk.
32	PX11A	fitting, plastic, elbow, white
33	PX110	fan, pfx1300hp
34	PX114C	cover, terminal block, pfx1300
35	PX117A	gauge, 0-300 psi, 2-1/2", abs,
36	PX118A	nut, pal, 3/4" wheel
37	PX119	1/4 nptf x 1/8 nptf reduce cou
38	PX133	sub, harness, switch panel
39	PX137	e clip, 3/4", pfx1300
40	PX14	dump valve gasket 1-1/2"
41	PX14A	dump valve gasket 1-1/2" thin
42	PX17	street elbow 45 degree brass
43	71512A	nipple, hex 1/2" for PFX1300HP, HDX, DX
44	PX25	fitting, plastic, bulkhead
45	PX26	caster, 3" dia. wheel
46	PX65	casters 4"for PFX1300HDX, DX
47	PX30	filter, mesh screen, solution
48	71495A	ball strainer for PFX1300HP, HDX, DX

MODEL PFX1300 SERIES CARPET EXTRACTOR PARTS

PFX1300 lower housing assembly

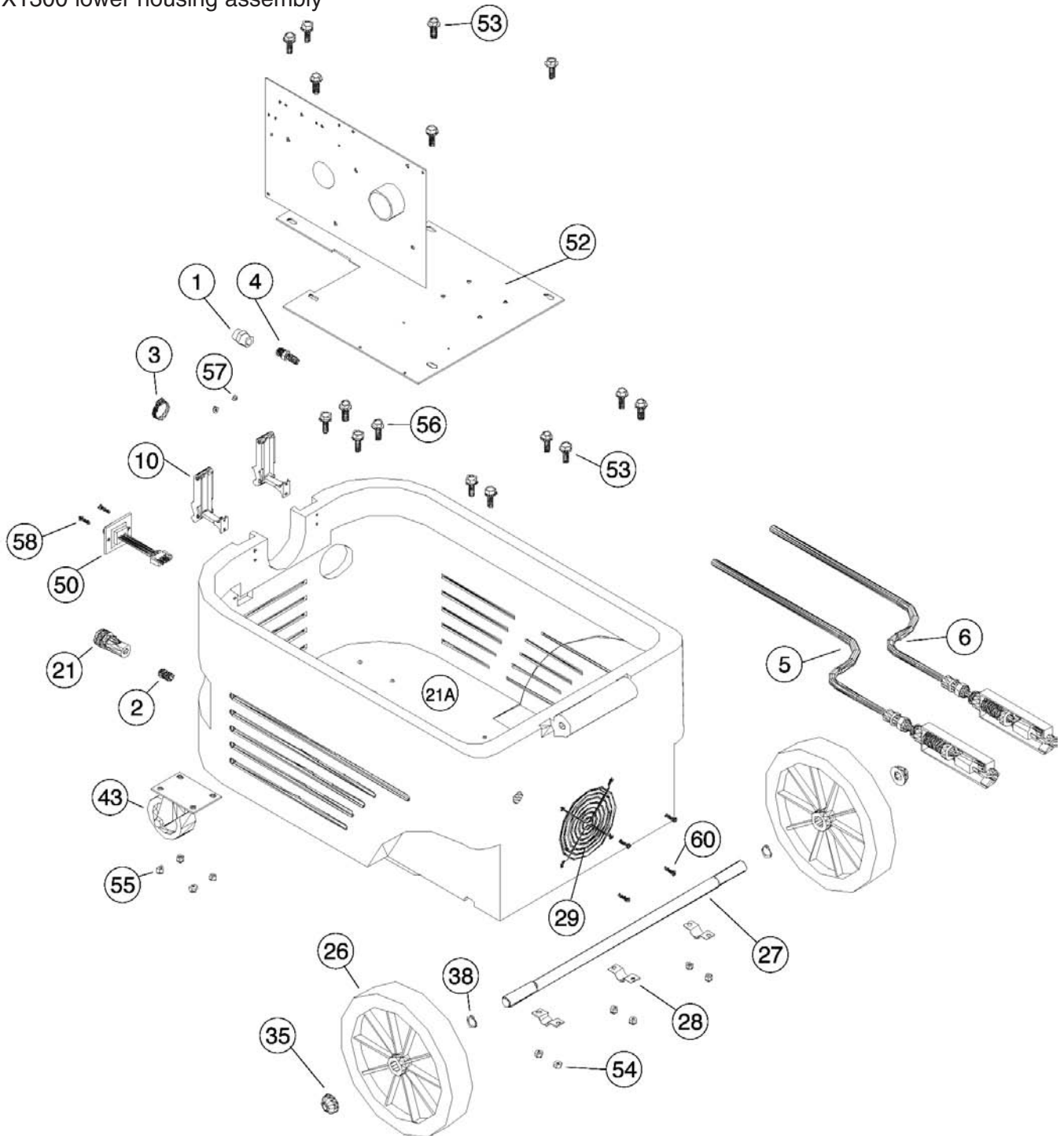

ref#	order	description
45	PX31	float cage w/heavy ball
46	PX33	float tube, pfx1300/h/hp
47	PX46	nut, lock, die cast, 1-1/2"
48	PX48	fitting, brass, bulkhead, 3/4"
49	772274A	washer, 3/4 neoprene
50	PX49	peb plug, pfx1300
51	PX6	1/4 x 1/4 female quick
52	PX98	motor/pump/plt, pfx1300hp
53	X82115	1/4-20 x 1" serrated hex self
54	X8237	nut, 1/4-20, lock, nylon insrt

ref#	order	description
55	X8248	nut, 5/16" lock w/nylon insert
56	X82525	5/16-18 x 1 hex flange lok scr
57	X8256	8-32 keep nut
59	X8271	10-24 nylon insert lock nut
58	X8276	10-24 x 3/4" phph, blk oxide
63	X8284	8-32 x 3/8" phph, type f
62	X8286	8-32 x 1" phph, type f
60	X8287	8-32 x 5/8" phph machine screw
61	X8298	8-32 x 3/4" phph

Troubleshooting Information

ELECTRICAL SYSTEM

PROBLEM	POSSIBLE CAUSE	SOLUTION
No electrical power.	1. Defective power cord. 2. Circuit breaker off or fuse blown.	1. Replace 2. Turn circuit breaker on or replace fuse. Unplug any equipment using the same circuit.
Switch is turned on. Intermittent power to motor(s).	1. Faulty electrical cable. 2. Defective switches. 3. Loose terminal or discolored terminal connections.	1. Repair or replace. 2. Replace. 3. Replace.
Electrical Shock	1. Equipment not grounded.	1. Locate grounded outlet.

VACUUM SYSTEM

PROBLEM	POSSIBLE CAUSE	SOLUTION
Vacuum motor on Little or no vacuum on wand head.	1. Drain valve open. 2. Defective vacuum hose	1. Close drain valve. Recovery tank lid must be closed. 2. Repair or replace hose. Kinks in vacuum hose.
Not enough vacuum power at the machine.	1. Damaged recovery tank lid. 2. Lint clogging ball - type shutoff screen. 3. Vacuum hose connection between stand pipe and vacuum motor (on models with 2 vac motors, the vacuum hose connection in between). 4. Vacuum motor exhaust blocked.	1. Replace 2. Remove screen. Clean out fibers and accumulated dirt. 3. Check for leaks around clamps (tighten). Replace damaged hose(s). 4. Check air flow by removing hose from machine and feel the exhaust under the machine. Remove obstruction.

VACUUM SYSTEM

PROBLEM	POSSIBLE CAUSE	SOLUTION
Motor running and no vacuum at all.	1. Faulty vacuum motor.	1. Replace.
No exhaust from the blowport.	2. Water shutoff closed.	2. Clean water shutoff screen.
Premature closing of ball type shutoff.	1. Dirty or clogged shutoff filter screen.	1. Remove and clean screen.
Ball type shutoff failing to release after recovery tank is drained.	2. Ball coated with detergent or other 2. Screen slightly out of round.	2. Remove and rinse ball with clean water. foreign material. 3. Bend screen by squeezing slightly by hand until there is an obvious space between ball and inside of screen.

Foam/dirty solution coming out of vacuum exhaust port.	1. Foam from carpet by-passing water shutoff. 2. Elbow in vacuum tank is not positioned correctly.	1. Use additional defoamer. 2. The elbow should be pointed directly at the side wall of the tank away from the ball type shutoff.
--	---	--

PROBLEM	POSSIBLE CAUSE	SOLUTION
Pump motor on – no spray through jets.	1. Clogged or faulty solution control valve. 2. Clogged or faulty quick disconnect on housing. 3. Punctured pump diaphragm.	1. Check intake on valve and remove lint or other foreign material. 2. Depress plunger on solution hose against inside wall of solution tank. If solution is flowing at this point, the system is O.K. If no solution flows, check the quick disconnect for lint and other foreign matter. 3. Replace with diaphragm repair kit.

PROBLEM	POSSIBLE CAUSE	SOLUTION
Uneven spray from jet. Spray weak or uneven.	1. Clogged strainer in solution tank. 2. Clogged jet.	1. Unscrew strainer and remove lint and any other foreign material from screen. 2. Remove and clean.
Leaking or stuck solution valve.	1. Foreign material in valve. 2. Loose brass hex nut. 3. Valve worn or seals worn.	1. Remove brass hex plug, clean valve and replace. 2. Reseal hex and plug. 3. Replace worn parts with solution valve repair kit.
Pump motor not working.	1. Loose wiring 2. Defective pump pressure switch 3. Motor burnout	1. Tighten wiring 2. Replace with new pressure switch assembly 3. Replace pump motor
Pump pressure low	1. Clogged screens on 2. Punctured pump diaphragm. 3. Defective rectifier or motor.	1. Unscrew strainer strainer in solution tank remove lint and any other foreign material from screen. 2. Replace with diaphragm repair kit. 3. Replace.
Pump pressure varies.	1. Worn carbon brushes. 2. Defective pump pressure control switch.	1. Replace brushes. 2. Replace.

WARRANTY

The manufacturer warrants to the original purchaser that products manufactured are free from defects of workmanship and material, provided such goods are installed, operated and maintained in accordance with written manuals or other instructions for a period of 5 years from date of purchase on housings and frame, 3 years on heater, 1 year on pump, vac motor, and parts and workmanship. In case you as our customer, meet any trouble with your machine, contact your Powr-Flite representative who will be happy to be of service to you and will take care of the warranty settlement.

NOTE: Alterations and changes made to the machine without written approval of the manufacturer and use of unapproved spare parts will not be covered by warranty.



A Tacony Company
3101 Wichita Court • Ft. Worth, TX 76140-1710