

Powr-Flite[®]

COMMERCIAL FLOOR CARE EQUIPMENT

Operator's Manual

Model P1500-3
1500 RPM
Burnisher



Powr-Flite[®]
COMMERCIAL FLOOR CARE EQUIPMENT

A Tacony Company
Fort Worth, Texas 76140

U.S. Patent Number 4,845,798

U.S. Patent Number 4,756,042

U.S. Patent Number 296,252

*Your new **Powr-Flite® Ultra High Speed Burnisher** will afford you many years of trouble-free operating satisfaction provided it is given proper care. Prior to packaging, your **Powr-Flite® Ultra High Speed Burnisher** was inspected by a **Quality Control Technician**.*

UNCRATING

Your **Powr-Flite** Ultra High Speed Burnisher was protectively packed to prevent damage in shipment. We suggest that upon removing the unit from its carton, you carefully inspect it for any possible damage in transit. If damage is discovered, immediately notify the transportation company who delivered your machine. As a manufacturer, we are unable to act upon any claim for concealed damage; you must originate the claim.

IMPORTANT SAFEGUARDS

This machine is designed to be safe when used to perform the functions specified in this Operator's Manual. Should damage occur to electrical or mechanical parts, the machine should be repaired by the manufacturer or competent service station before using in order to avoid further damage to the machine or physical injury to user. Your floor machine is equipped with a safety switch lockout device designed for your safety. Do not attempt to bypass or defeat the safety lockout device. Never use any device to lock the power switch triggers in the ON position.

WARNINGS

READ THIS OPERATOR'S MANUAL!

WARNING: You must have training in the operation of this machine before using it.

WARNING: Machines can burn flammable materials and vapors. Do not use this machine with or near fuels, grain dust, solvents, thinners or other flammable materials.

WARNING: Do not operate this machine unless it is completely assembled.

WARNING: Do not use this machine as a step or to move furniture.

WARNING: When disconnecting power cord from electrical outlet, grasp the plug. Pulling it out by the cord itself can damage cord insulation and internal connection to plug. To prevent electric shock, always remove the electrical plug from the electrical outlet before doing any repairs or maintenance to this machine.

WARNING: To prevent injury, always remove the electrical plug from the electrical outlet before changing the polishing pad and before leaving the machine.

WARNING: To prevent injury, keep hands, feet and loose clothing away from the rotating pad.

WARNING: Maintenance and repairs must be done by authorized personnel only.

WARNING: Keep all fasteners tight. Keep adjustments according to specifications.

WARNING: Keep the electrical parts of the machine dry. For storage, keep the machine in a building.

WARNING: Always use a three-wire electrical system connected to the electrical ground. For maximum protection against electric shock, use a circuit that is protected by a ground fault circuit interrupter. Consult with your electrical contractor.

WARNING: To prevent damage to the power cord, do not let the pad, pad driver or wheels touch the power cord when the machine is running. Always lift the power cord over the machine.

WARNING: Make sure all labels, decals, warnings, cautions and instructions are fastened to the machine.

INSTRUCTIONS

Application

The P1500-3 Ultra High Speed Burnisher is used to achieve and/or maintain a high gloss appearance on an established floor finish. The high pad revolution of the floor burnisher combined with a good polishing pad will turn properly established cleaned floor finish into a high gloss, hardened finish known as the "wet look" shine. The pads recommended with the P1500-3 are the **Powr-HD** beige or white synthetic pads or the natural hogs hair blended pads.

Preparation of Surface

Before each use of this machine, the floor must be dust mopped with a treated mop and if necessary clean the floor with a damp mop, using a solution of water and neutral cleaner, such as **Powr-Kare**.

PREPARE THE MACHINE FOR OPERATION

WARNING: To prevent injury, always remove the electrical plug from the electrical outlet before changing the polishing pad and before leaving the machine.

- With the handle locked, tip the machine back until the handle is lying flat on the floor.
- To remove the pad center grip on the pad driver, place your thumb on one tab and your forefinger under the other tab. Push with your thumb and pull with your forefinger to remove collar of the center grip. **See picture #1**
- Place a clean or new 20" buffing pad (*such as Powr-HD beige UHS buffing, hoghair blend, or white polishing pads*) over the alignment ring on the pad holder. **See picture #2.**



Picture #1



Picture #2

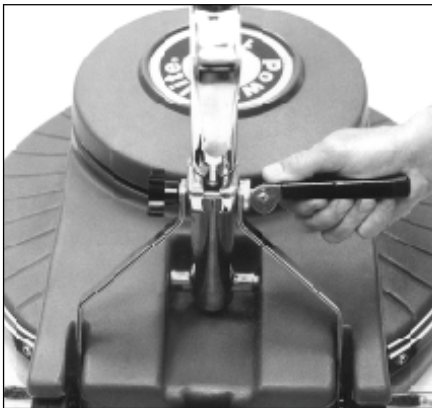

Picture #3



Picture #4

- Push the collar onto the pad center grip to hold the pad in place.
- Step back and lift the burnisher to the upright position.

NOTE: The pad level adjustment control is preset at the factory in the raised position. Do not adjust the pad level unless the pad you are using is thin or worn (1/2" or less).

- Connect the power cord into a grounded, 3-wire outlet.
- Unlock the handle cam release lever (*See picture #3*) and bring handle to a comfortable operating position. Waist high position allows best performance. Lock the cam lever release into position.

NOTE: The hardened steel cam release lever does not require extreme tightening to effectively hold the handle in position. Over-tightening will shorten the functional life of the lever.

See picture # 3.

HOW TO OPERATE THE MACHINE

First install the pad driver and pad, brush or other attachments to be used. Plug the machine in as directed and lower the handle to the desired operating height and lock in place using the cam lever handle. Push the safety switch forward and squeeze the switch triggers beneath the handle grips. This activates the motor and starts the block, brush or attachment in operation. Each time you release the triggers the safety switch will reset. You will need to follow the direction above to restart the machine. **CAUTION:** *When leaving the machine unattended, disconnect the wall plug and return the handle to the "locked" upright position to prevent accidental starting.*

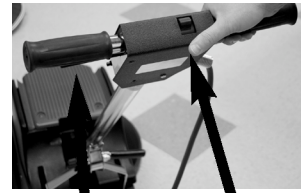

Switch
Trigger

Safety Switch

NOTE: Burnisher will pull to the right on start up because of the torque generated by the immediate 1500 RPM revolution of the pad.

- Push the machine forward in a straight line, at a slow walking speed. Overlap each pass by about 1 inch (25 mm).

AFTER USING THE MACHINE

- Upon completion, dust mop with treated mop to pick up all burnishing residue.
- The condition of the floor pad has direct affect on the performance of your burnisher. When the pad becomes dirty, turn it over and use the other side. When finished, wash the pad out and allow it to dry completely before using again.
- Unplug the power cord and wrap it under the cord hook and over the right handle grip.
- Tip the machine back and remove floor pad.
- Wipe off the machine housing and the cord. This will prevent build-up of unnecessary residue.

TRANSPORTING

Use the rear wheels for transporting the P1500-3. This will ensure that the operating wheels remain clean and smooth for use on clean floor surfaces.

See picture # 4.

MAINTENANCE

- Once a month, remove the motor cover of the unplugged P1500-3 by pulling evenly, but firmly, with both hands until cover is removed.
- Vacuum out any dust or debris which has accumulated in the motor.
- Replace motor cover by setting it over holes in housing and firmly pushing down.
- Check and maintain tightness of all fasteners.
- Keep the burnisher clean, especially at the handle tube and collar so the handle tube will move freely through the collar.
- Inspect cord and plug for cuts, gashes or loose prongs; replace as needed.
- The length of the carbon brushes should be inspected annually. If they are no longer extended past the holder window $\frac{3}{8}$ ", they should be replaced.
- Replacement of carbon brushes should be done only by a qualified service technician.
- Disassembly of this motor voids the warranty.
- Improper disassembly and assembly of this motor can permanently damage the armature.

WARNING: Do not over-tighten switch housing screws.

TROUBLESHOOTING

Burnisher tends to move to the right.

- Do not lift up on handle while operating the burnisher.
- Do not operate with handle set too high. Recommended handle height is from your waist with your arms extended forward.

Burnisher tends to move to the left.

- Pad level adjustment is too low. Turn the pad level adjustment control knob counterclockwise until it can no longer turn.
- The pad level adjustment control is designed to establish greater surface contact when pads wear thin or if pads are less than one inch thick.

Burnisher does not run.

- Circuit breaker has tripped. Allow circuit breaker to cool two minutes before resetting.

Prevent circuit overload.

- Check and adjust pad level control to counter-clockwise position.
- Check pad and change if dirty or rough.
- Check area being burnished for cleanliness, area should be damp mopped, scrubbed or swept with treated broom.
- Operator should not continually force the machine with handle pressure.

- Operator should not try to operate burnisher in a side-to-side motion.
- Eliminate any extension cord that is smaller than 12/3 wire or greater than 25 feet in length.
- Unplug anything else on the circuit or locate another circuit.

Burnisher will not start.

- Circuit breaker is not reset. Reset breaker.
- Plug is broken or has loose contact. Replace.
- Circuit breaker is defective or weak. Replace.
- Switch is defective. Replace switch.
- Rectifier is defective. Replace.

GROUNDING INSTRUCTIONS

This Floor machine is intended for use on a nominal 120 volt circuit, and has a grounded plug that looks like the plug illustrated in **(FIG A)**. A temporary adapter that looks like the adapter illustrated in **(FIG B & C)** may be used to connect the plug to a 2-pole receptacle as shown in **(FIG. B)** if a properly grounded outlet is not available.

The temporary adapter should be used only until a properly grounded outlet **(FIG. A)** can be installed by a qualified electrician. The green color rigid ear, lug, or the like, extending from the adapter must be connected to a permanent ground such as properly grounded outlet box cover. Whenever the adapter is used, it must be held in place with a metal screw.

WARNING: Improper connection of equipment-grounding conductor can result in a risk of electrical shock. Check with a qualified electrician or service person if you are in doubt as to whether the outlet is properly grounded.

DO NOT modify the plug provided with this appliance. If it will not fit the outlet, have a proper outlet installed by a qualified electrician.

NOTE: In Canada, the use of a temporary adapter is not permitted by the Canadian Electrical Code.

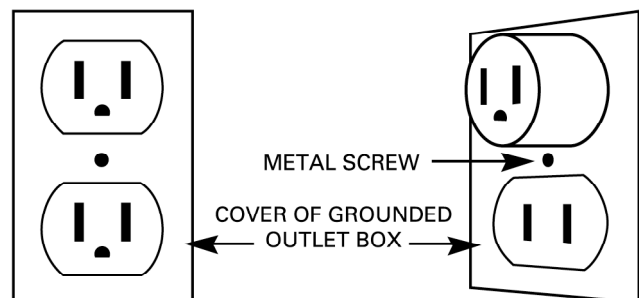

Model P1500-3

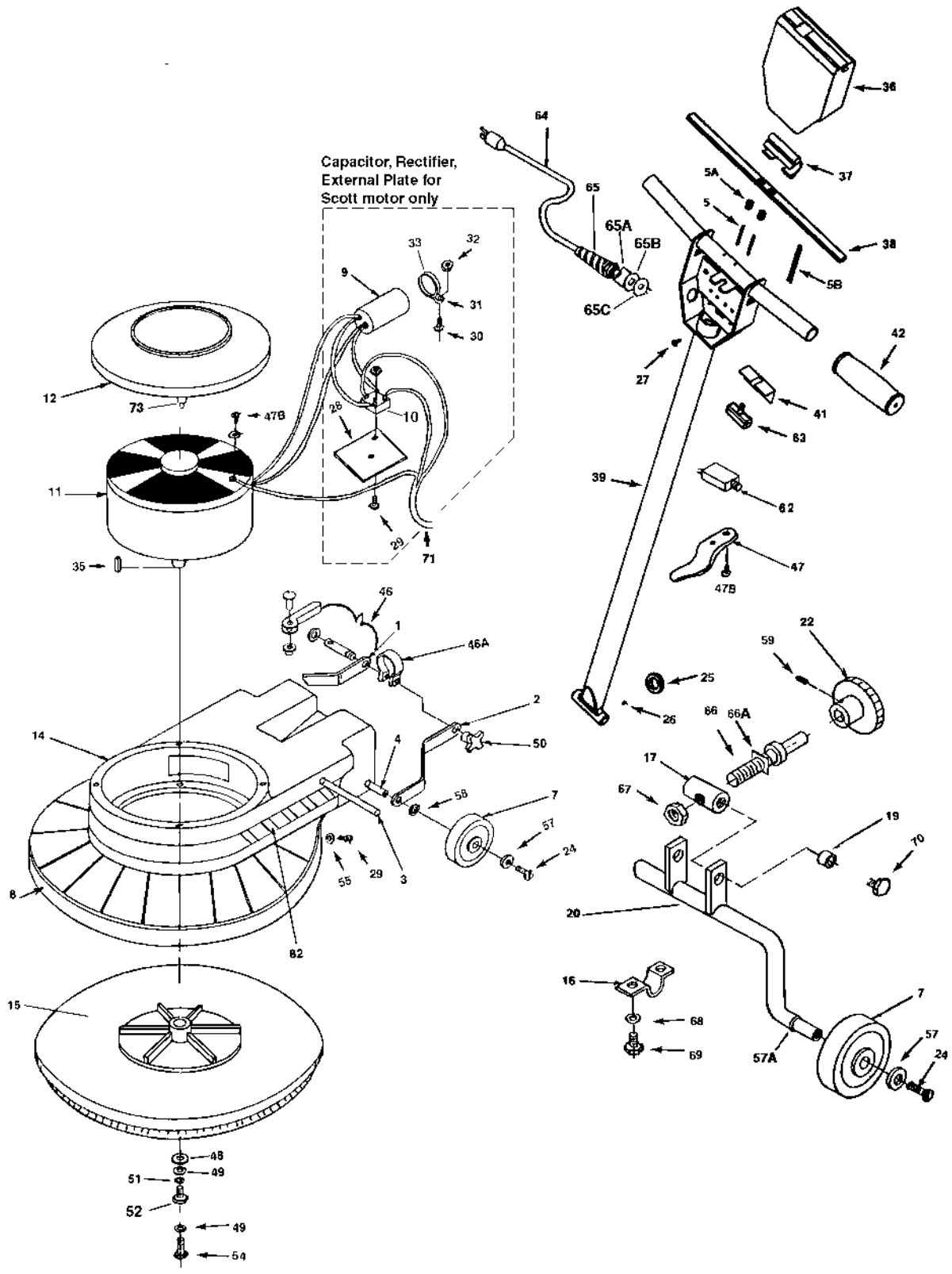

ref#	order	description
1	X8017R	right brace
2	X8017L	left brace
3	X8018	pivot shaft
4	X8019	11-5/8" axle
5	X8918	handle roller pin (2 req.)
5A	X8916	trigger tension spring (2 req.)
5B	X8915	handle trigger thumb actuation spring
7	X8025	4" wheel
8	X8030	46" bumper
9	X8033	1200 UF capacitor
	X8955	start capacitor 380 UF 125V
	X8956	run capacitor 60 UF 370V
10	X8034	rectifier, 35 amp, for machines with Scott Motors
	X8034-2	rectifier, 50 amp, for machines with Imperial Motors
11	X8909	1.5 hp gear motor assembly
12	X8042	motor cover
14	X8051	base housing
15	X8080	drive block with drive plate
16	X8081	wheel axle bracket
17	X8082	pivot block
19	X8084	bushing
20	X8085	wheel axle weldment
22	X8087	knob
24	X8210	wheel screw
25	7BG004	7/16" dia. grommet
26	X8222	1/4-20 x 3/16" set screw
27	X8207	#10-24 screw (3)
	7CY001	lock washer (3)
28	X8023B	heat sink for rectifier
29	X8208	10-24x5/8" phillips head machine screw
30	X8202	mount bolt
31	X8150M	mount for capacitor strap
32	X8203	8/32 mount nut
33	X8150	capacitor cable tie
35	X8047	motor key
36	X8912	switch box cover
37	X8914	thumb actuation release
38	X8917	handle trigger
39	X8911	1-1/2" dia. handle tube weldment
40	X8005	handle tube
41	X8923	insulation sheet
42	X8941	handle grip 1" inside dia.
46A	X8012	handle clamp collar
46	X8012A	handle clamp assembly
47	X8013	cord hook
47B	X8207	10/24"x1/2" type F machine screw (2 req.)

ref#	order	description
48	X8230	3/8" SAE wrought washer
49	X8219	3/8" SAE flat washer (4)
50	X8016	knob
51	X8217	5/16" spring lock washer
52	X8215	15/16" - 18x3/4" hex cap bolt
54	X8227	5/16"-18x1-1/4" HHCS (4)
55	X8225	3/16" cut washer
57	X8020	axle washer
57A	X8224	spacing washer (2)
58	X8101	spring washer (2)
59	X8205	10/32"x3/8" socket set screw
62	X8023A	17 amp circuit breaker
63	F5P	switch, 25 AMP
64	M1400	14/3 SJTW-A 75' power cord, yellow
	M1400S	14/3 SJTW-A 75' yellow cord assembly with metal strain relief and flag receptical
65	SR37	strain relief
65A	SR37A	brass sleeve, strain relief
65B	X8228	11/16" I.D., flat washer
65C	X8100	counter nut
66	X8083	adjusting screw
66A	X8221-1	screw stop
67	X8221	1/2"x13" hex nut
68	X8212	1/4" spring lock washer (4)
69	X8209	1/4"-20x1/2" hex end cap screw (4)
70	X8215	5/16"-18x3/4" hex head bolt (2)
73	X8105	spacer, motor cover (4 req.)
NOT ILLUSTRATED		
	X8022	cord assembly (handle)
	X8036K	fastener packages Imperial motor
	X8048	carbon brush and spring (Scott motor)
	X8048-1	negator spring for X8048
	X8512	carbon brush (Imperial motor)
	X8213	nut for X8210-1
	X8222	1/4"-2x3/4" socket set screw for X8011 handle
	F50P	power grab pad holder
	F51P	snap in top ring for F50P
	X8049	brush holder
	X8150	capacitor strap
	X8180	6205 bearing
	X8108	wheel spacer
	X8220	long, switch housing screw
	X8210-1	short, switch housing screw and nut

*Call for part number and pricing.

*** X8036, NLA-Order X8036-1 and X8036K if replacing Scott motor**

***ONE LAST REMINDER! READ ALL INSTRUCTIONS,
WARNINGS AND CAUTIONS BEFORE USING EQUIPMENT.***

These guidelines are presented for your protection and convenience. Please read them carefully, since a failure to heed these precautions could result in discomfort or injury. When using an electrical appliance, basic safety precautions should always be followed.

WARNING!
**TO AVOID FIRE, DO NOT USE WITH A FLAMMABLE OR
COMBUSTIBLE LIQUID TO CLEAN FLOOR.**

Power-Flite
COMMERCIAL FLOOR CARE EQUIPMENT

A Tacony Company
Fort Worth, Texas 76140