

# **Powr-Flite**

**COMMERCIAL FLOOR CARE EQUIPMENT**

## **Model B2001 Battery Burnisher**

### **OPERATING INSTRUCTIONS**

COMMERCIAL BATTERY BURNISHER

#### **CONGRATULATIONS**

YOU HAVE JUST ACQUIRED A HIGH QUALITY BATTERY BURNISHER. PLEASE READ THIS MANUAL CAREFULLY, BEFORE OPERATING YOUR NEW BURNISHER. KEEP MANUAL ON HAND FOR FURTHER REFERENCES.



**Save These Instructions**

# SAVE THESE INSTRUCTIONS FOR FUTURE REFERENCE

\*When using an electrical cleaner, basic precautions should be followed.

\*Read all instructions before using burnisher.

## Operating instructions:

1. Make sure burnish pad is on and attached properly.  
*See Pad changing instructions.*
2. Adjust pressure on burnish pad by turning "Caster knob" clockwise to INCREASE pressure on burnish pad.
3. Move "Toggle switch" to "On" position; green light will be on.
4. Check battery condition meter" before operating. Meter should be in the working range" to operate.
5. Adjust handle to proper operating position height by lifting pin at left side of handle and raising or lowering the handle to desired position. Then insert pin in nearest hole.
6. Twist handgrips forward to operate.
7. Check "LOAD METER" for proper gauge pressure.  
*See Adjusting pad pressure for instructions.*
8. The Electronic Controller will "shut down" machine if over loaded and will require power turned off to "reset".

## Pad changing instructions:

1. Remove lower pin from rear castor mount.
2. Tilt machine back toward handle. Front of machine should be off of the ground about 10-12 inches.
3. Unscrew blue "Pad retainer" by turning counterclockwise. Blue retainer must be removed before replacing pad.
4. Remove pad for replacement.
5. Center new pad on "Pad driver".
6. Replace blue "Pad retainer" and tighten by turning clockwise. Tighten blue retainer until it bottoms out. Do not over tighten.

## Adjusting pad pressure:

1. With machine turned on and handgrips in the operating position, check "LOAD METER" for pressure.
  - a. White area - pressure is too low.
  - b. Green area - pressure is good.
  - c. Red area - pressure is too high.
2. To adjust to desired pressure:
  - a. Turn "Caster knob" clockwise to INCREASE pad pressure.
  - b. Turn "Caster knob" counterclockwise to DECREASE pressure.
3. For the best performance, "LOAD METER" should be kept in the "green" area.
4. Note: Too much pad pressure will shorten run time and will result in poor floor finish.

## Charging batteries:

1. See instructions on charger before operating.
2. Move "Toggle switch" to "Off" position; green light will be off.
3. Lift and remove "Upper hood cover".

4. Place charger plug into mating plug on machine located on the left side behind batteries. Plug will only connect together one way.
5. Then plug charger into proper outlet.
6. **Note:** Burnisher MUST NOT be turned on when charging.
7. Disconnect charger at outlet and at Burnisher before operating.

## Fuse blown:

1. Move "Toggle switch" to "Off" position; green light will be off.
2. Remove the "Upper hood cover".
3. Disconnect the wires from the "Positive terminal" of the last battery (the one nearest the handle),
4. Remove the "Rear panel"; the handle is attached to the rear panel, by unscrewing the 10 bolts.
5. Disconnect wires running from the "Handle" to the "Chassis".
6. Unscrew "Fuse" located in lower left hand corner of opening.
7. Screw new "Fuse" to holding blocks.
8. Reattach wires running from the "Handle" to the "Chassis".
9. Replace "Rear panel" and secure with screws.
10. Reconnect wires to "Positive terminal".
11. Replace "Upper hood cover".
12. Raise the burnish pad by turning "Caster knob".  
*See Adjusting pad pressure for instructions.*

## Preventive maintenance:

1. Check batteries for water level each week.
2. Check batteries with a hydrometer every month.
3. Check battery connections each week.
4. Clean battery terminals every month.
5. Check vacuum bag for rip or tears.
6. Empty vacuum bag when full.
7. Check for any loose bolts or screws every month.

## Troubleshooting

1. Green light will not come on.
  - a. Check battery meter, if reading ok green light is bad.
  - b. Check circuit breaker on control panel.
  - c. Check battery connections.
  - d. Check fuse behind rear panel and power switch.
  - e. Check wire connections to light.
  - f. Check light.
2. Motor will not run.
  - a. Check batteries and battery connections.
  - b. Check wire connections to motor.
  - c. Check fuse behind rear panel.
3. Fuse is blown.
  - a. Check pad pressure
  - b. Check motor.
  - c. Check wires.

# Model B2001 Parts

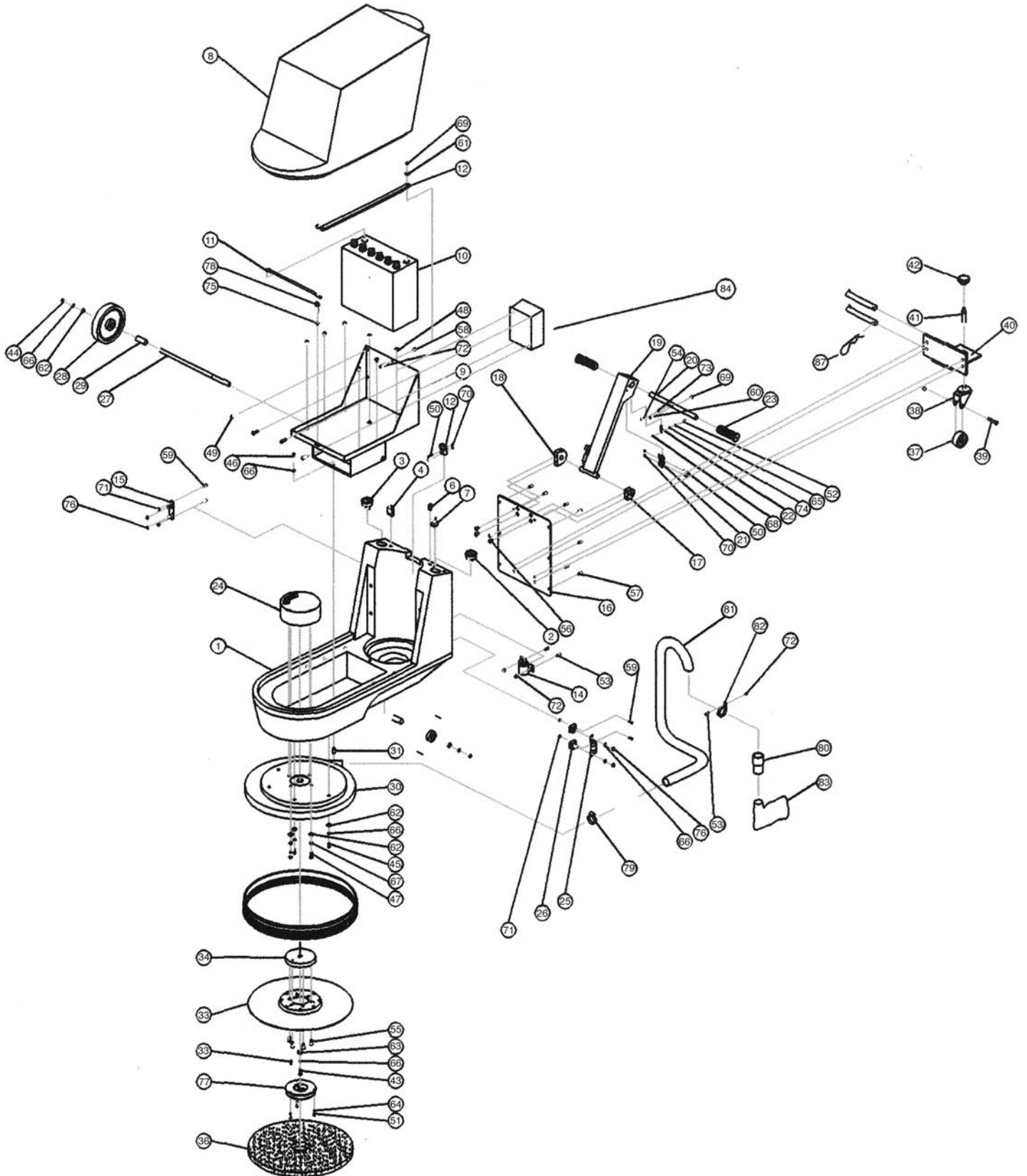

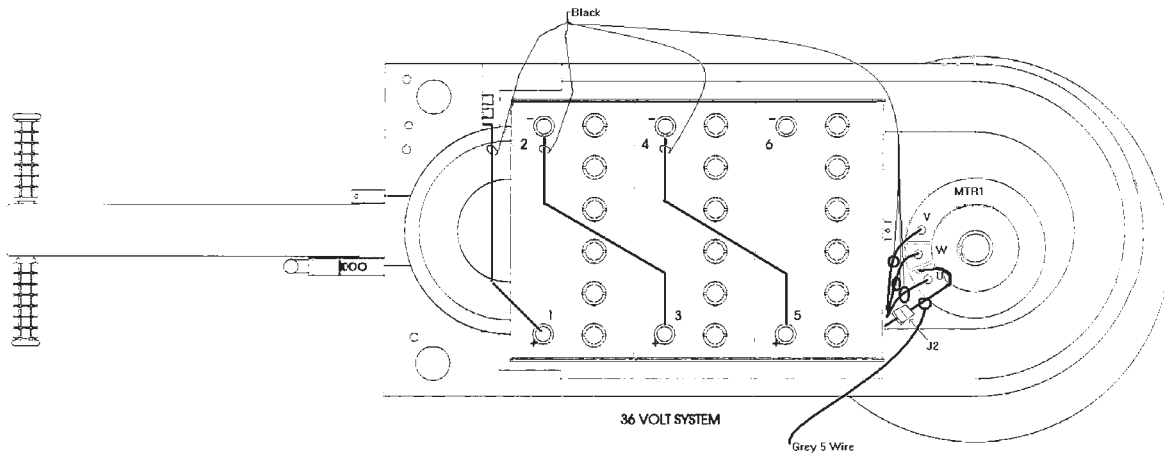

### Model B2001 Parts

Ref #	Part #	Description
2	MB2	BATTERY CONDITION METER
3	MB3	RPM LOAD METER
4	MB40	10A CIRCUIT BREAKER
6	MB5	36VDC INDICATOR LIGHT-GREEN
7	MB7	TOGGLE SWITCH
8	MB8	HOUSING, UPPER HOOD COVERING
11	MB47	BATTERY CABLE
14	MB14	DC CONTACTOR
15	MB115	SHUNT
17	MB17	HANDLE ADJUSTING BLOCK
18	MB18	HANDLE POSITIONING BLOCK
24	MB124	Brushless Motor
25	MB125	FUSE100A
27	MB127	AXLE B2001
28	MB25	WHEEL
29	MB33	WHEEL SPACER
30	MB27	PAD SKIRT

Ref #	Part #	Description
31	MB29	PAD SKIRT SPACER
32	MB28	BRUSH SKIRT
33	MB32	21" PAD DRIVER ASSY.
34	MB134	Pad Driver Adapter
37	MB36	3" CASTER
38	MB41	CASTER YOKE
39	MB42	CASTER AXLE AND NUT
40	MB140	CASTER MOUNT BRACKET
41	MB38	CASTER STEM ADAPTER
42	MB39	CASTER KNOB
62	MB46	BEARING, REAR WHEEL FLAT WASHER
65	MB31	#10 LOCK WASHER B2000
73	MB50	#8-32 X1 SLOT ROUND HEAD
76	MB30	5/16-18x 1-1/2 HEX HEAD BOLT
84	MB126	ELECTRONIC CONTROLLER

### *The Powr-Flite Limited Warranty*

The manufacturer warrants to the original purchaser that products manufactured are free from defects, provided such goods are installed, operated and maintained in accordance with written manuals or other instructions for a period of 1 year from date of purchase on workmanship, motor, and parts, switch, and yoke. In case you, as our customer, meet any trouble with your machine, contact a Powr-Flite representative, who will be happy to be of service to you and will take care of any warranty issues.

***Powr-Flite***  
**COMMERCIAL FLOOR CARE EQUIPMENT**

*A Tacony Company*

Ft. Worth, TX 76140

1-800-880-2913