

# Predator Automatic Scrubber 40

## OPERATORS MANUAL AND PARTS LIST

### Model PAS40R



**WARNING: OPERATOR MUST READ AND UNDERSTAND THIS MANUAL COMPLETELY BEFORE OPERATING THIS EQUIPMENT.**

# **IMPORTANT SAFETY INSTRUCTIONS**

**All operators must read, understand and practice the following safety instructions. They will be repeated occasionally throughout this manual, and additional cautions may be added for specific causes.**

The PAS40R Automatic Scrubber is a battery equipped auto scrubber designed for ease of use, manageability and safety. This manual should be retained for the life of the machine.

This manual is to ensure that the PAS40R is operated correctly. All operators must read, understand and adhere to the instructions contained within the manual. Powr-Flite accepts no responsibility for damage to persons, or things, or damage to the machine if the PAS40R is not operated as indicated in this manual, or if maintenance and safety instructions are not fully complied with.

The instructions provided in this manual do not replace the safety instructions and technical data for installation and operation directly applied on the PAS40R, nor do they replace the safety standards current in the country of installation.

Powr-Flite is not responsible for the disposal of products necessary for the operation of the PAS40R; e.g. batteries, solutions, etc. The customer must arrange for the proper disposal of these substances in accordance with the environmental laws of the country in which it is used.

**CAUTION:** Operators must read and understand this manual completely before operating the equipment.

**CAUTION:** Make sure all caution, warning, and instructional decals are in place and legible. Replace damaged or missing labels.

**CAUTION:** Store or park this machine on a level service only. Remove key from switch if machine is left unattended.

**CAUTION:** Never leave the machine unattended, particularly when there are children present.

**CAUTION:** Engage the safety brake every time the machine is left attended.

**CAUTION:** Do not operate machine or charger in areas where flammable liquids or gases are present.

**CAUTION:** Do not use or pick up flammable chemicals or liquids with this machine.

**CAUTION:** Make sure the key switch is turned "OFF" and the battery connector unplugged from the machine before filling the solution tank.

**CAUTION:** Make sure the key switch is turned "OFF" and the battery connector unplugged from the machine before installing pad or brushes.

**CAUTION:** Do not operate this machine in bare feet or with open-toed shoes or sandals.

**CAUTION:** Keep hands and feet away from revolving pad.

**CAUTION:** Remove all loose objects from the floor prior to operating the machine. Loose objects can become dangerous projectiles if struck by the high-speed pad.

**CAUTION:** Keep machine moving at all times to prevent damage to floor or finish.

**CAUTION:** Do not operate this machine on ramps or inclines.

**CAUTION:** Maintenance and repairs must be performed by authorized personnel.

**CAUTION:** Never attempt to make emergency repairs or use non-original spare parts.

**CAUTION:** Make sure the key switch is turned "OFF" and the battery connector unplugged from the machine before performing any maintenance procedures.

**CAUTION:** Do not expose electrical components to water or other liquids. To clean machine, wipe down with a damp cloth.

**CAUTION:** Check the wear and deterioration of the parts and materials on a regular basis. Do not attempt to operate the equipment with worn parts.

**CAUTION:** When working on or around batteries, wear protective clothing and safety glasses. Remove metal jewelry. Do not lay tools or metal objects on top of batteries.

**CAUTION:** Do not smoke or expose open flames or sparks in the vicinity of the batteries (portable grinders, welders, etc.).

**CAUTION:** Do not take current from the batteries using jumper cables or other forms of temporary connections.

**CAUTION:** Charging batteries generate explosive gasses. **NO SMOKING OR OPEN FLAMES OR SPARKS.** Make sure the charger has turned off before disconnecting it from the batteries. Charge the batteries in a well-ventilated area with the tanks in the raised and locked position.

**PAS40R Features and Benefits**

The Powr-Flite PAS40R battery operated auto scrubber is designed specifically for large areas and features the convenience of ride-on comfort. Operators will be able to clean larger areas with fewer breaks and with less fatigue. The PAS40R is extremely simple to use and maneuvers easily around corners and other obstructions. The PAS40R provides the convenience of cleaning and drying in one simple pass. The curved 46" squeegee dries the floor even on tight turns. The PAS40R is built to last, providing maximum life with low operating cost. The rugged frame is made of 30/10 sheet steel with a polyethylene constructed housing. Safety features protect against misuse and accidents. The PAS40R is well equipped to handle the most demanding cleaning jobs!

- 64,000 square feet per hour cleaning ratio
- 40 inch cleaning path
- 45 gallon tank capacity
- Twin vacuum motors
- 4-6 hours run time

- Frame constructed of 30/10 sheet steel protected by a heat-hardened paint.
- Tight frame and polyethylene tank resistant to battery chemicals and to the most widely diffused industrial solvents.
- Polyurethane coated wheels.
- Electronic adjustment of brush pressure.
- Reduction motors with brushes with lifetime lubrication.
- An advancing motor equipped with a controlled-speed transmission and an electronic circuit board.
- By-pass suction motor for liquids.
- A control panel made of shock-proof PVC with protected switches.
- A dryer shoe made of cast aluminum, with rubber scrapers made of natural para material.

**General Instructions**

The PAS40R generates 80dB in an industrial environment (warehouse/shop floor) and is harmless for the operator. However, in other surroundings, this decibel level may be exceeded in which case the operator must wear appropriate ear protection.

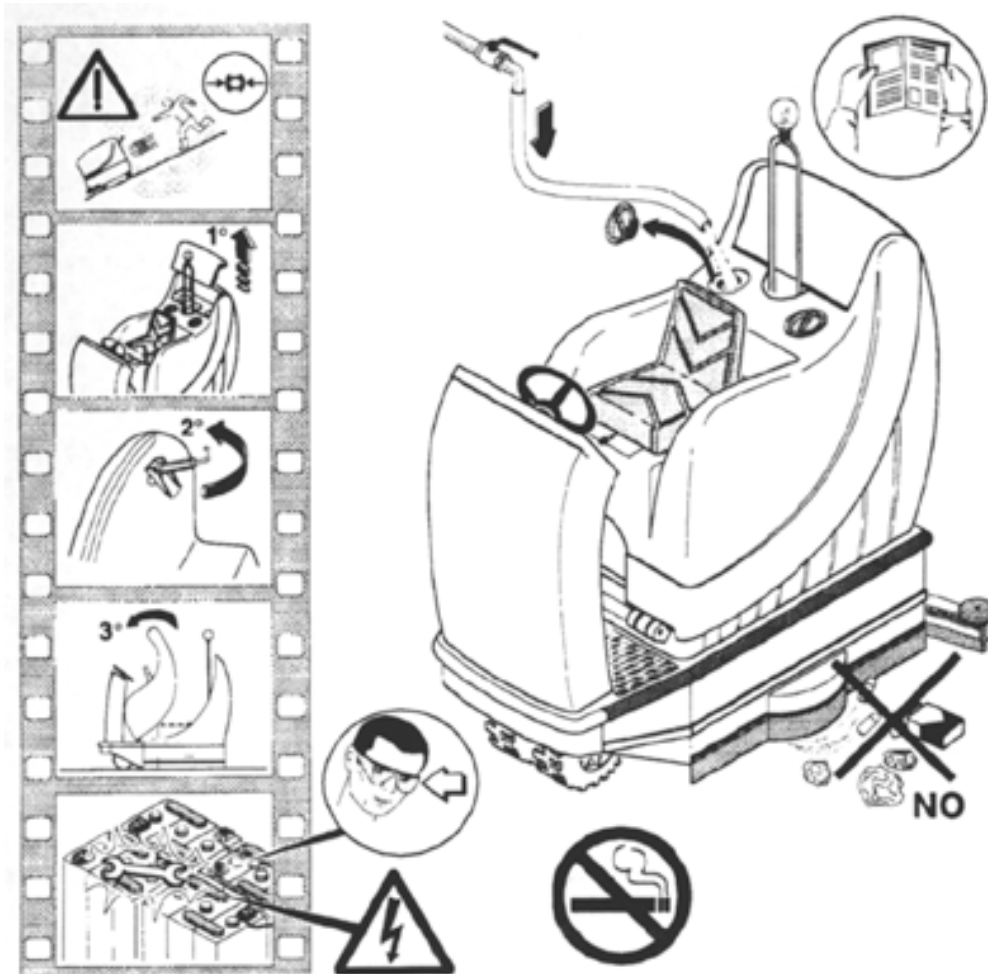

Standards for safety must be followed in accordance with the country laws where the equipment is being operated.

The PAS40R is designed to be simple, easy to operate, and safe. Guidelines must be followed to ensure compliance with safety issues.

Operators must be dressed appropriately with no loose clothing, wide sleeves, dangling belts, ties, or other articles of clothing that could become entangled in the machine. Shoes must also be appropriate for the environment with no bare feet, no sandals or open toed shoes and no wet feet.

The PAS40R is designed to work in closed industrial environments on level floor or on inclines no steeper than 2%.

**CAUTION:** Do not operate machine or charger in areas where flammable liquids or gases are present.

**CAUTION:** Do not use or pick up flammable chemicals or liquids with this machine.

To prepare the area for cleaning, all loose objects must be picked up prior to using the auto scrubber. Major dirt should be cleared with an automatic sweeper or manually to avoid immediately choking the intake circuit. This preparation will also allow the solution to work more effectively.

Should the area require particular attention or a second pass of the auto scrubber, it is most effective to make one pass with the wiper raised and the brush in the working position. The solution will remain on the floor longer and will dissolve the tougher dirt. The second pass should be made with the brush and wiper lowered and at a slower speed.

**CAUTION:** The charger must be switched off before disconnecting it from the batteries.

When the area is prepared for cleaning, switch off the battery charger and disconnect it from the PAS40R. Adjust the seat position of the machine to suit the requirements of the operator by using the (M16) lever. The PAS40R is ready for operation.

### **Operating the PAS40R**

The PAS40R is designed with a safety feature that prevents operation of the machine unless an operator is seated. Once seated with the seat adjusted to the proper position, cleaning can begin.

1. Place the (M14) lever in the, central, NEUTRAL position and grip the (M17) steering wheel.

2. Insert the (M7) key switch to enable the electrical circuits.
3. If an acoustic BEEP signal sounds, the parking brake is engaged and should be released with the (M19) pedal.
4. Engage brush rotation with (M12) potentiometer and the aspirators with the (M13) switch.
5. Gradually open the solution supply tap (M18) according to the speed of operation.
6. Engage the FORWARD or REVERSE gear with the (M14) lever and gradually depress the (M22) accelerator pedal. When the PAS40R is in movement, the (M28) lamp flashes. When the REVERSE gear is engaged an acoustic BEEP signal is emitted.

### **Instrumentation**

M1	Detergent intake plugs
M2	Waste water rapid drainage tap
M3	Waste water rapid drainage pipe
M4	Floor-wiper adjustment knobs
M5	Battery charging connector
M6	Emergency button
M7	Start-up key switch
M8	Forward speed regulator (from 1 to 10)
M9	Working hours (brushes in operation) recorder and battery charge gauge
M10	Ammeter indicating power absorption of brush motors
M11	Brush rotation engagement pilot light
M12	Brush ignition and regulator (from 1 to 10)
M13	Aspirator start switch
M14	Forward-neutral-reverse gear lever
M15	Horn
M16	Seat position adjustment lever
M17	Steering wheel
M18	Solution supply lever
M19	Parking brake
M20	Parking brake locking lever
M21	Brake
M22	Accelerator
M23	Brush engagement knob
M24	Floor wiper pressure knob
M25	Solution rapid drainage pipe
M26	Solution rapid drainage tap
M27	Motor stop ring
M28	Drive engaged warning lamp
M29	Exhaust gasket
M30	Skirt support rod
M31	Detergent filter
M32	Protection fuse control panel

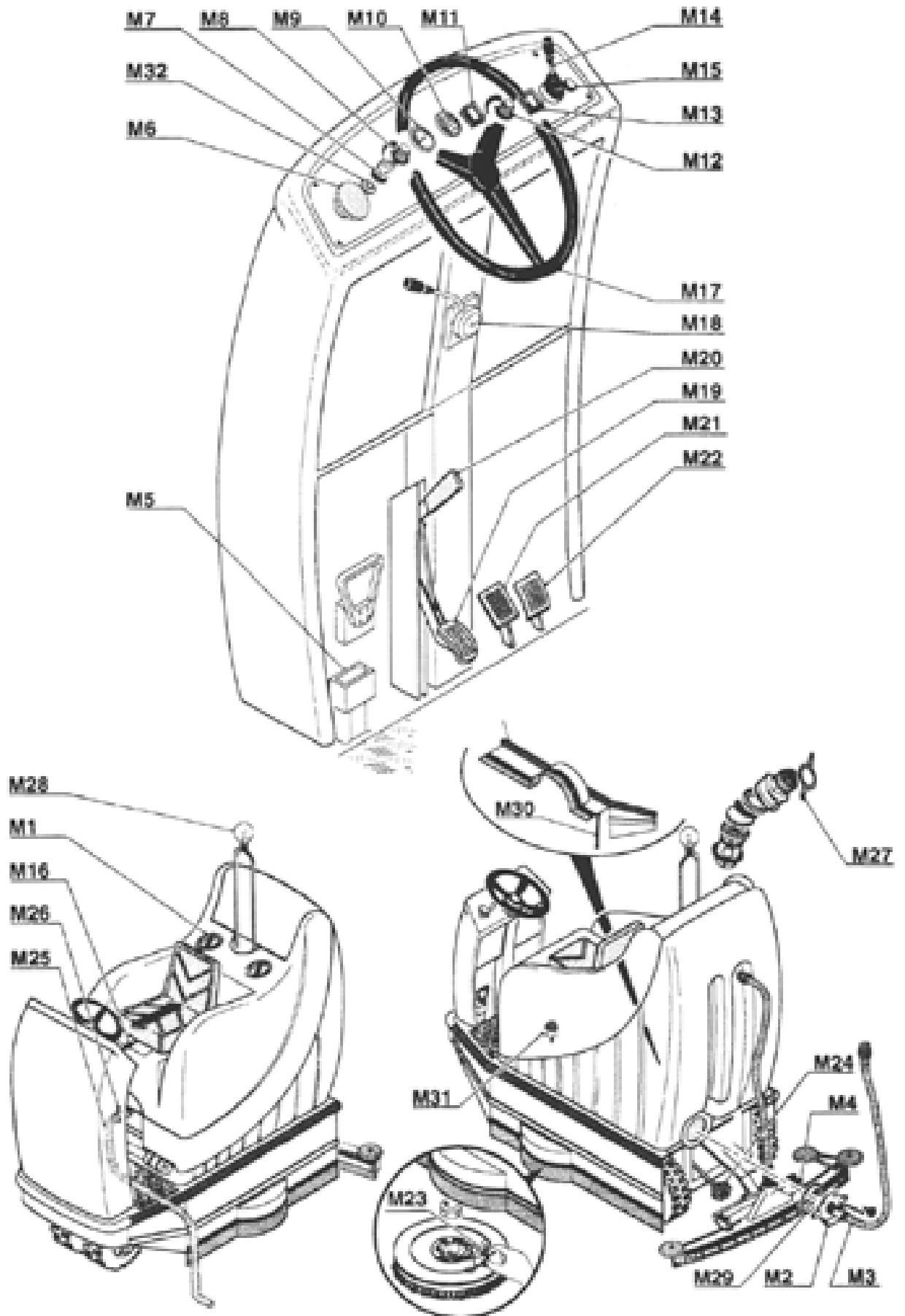

7. With the accelerator pedal fully depress, the (M8) regulator can be adjusted to achieve a constant speed. This will avoid the formation of rings on the floor.
8. Adjust the brush pressure with the (M12) regulator.
9. Correct brush operator as indicted by the (M10) ammeter.
10. The (M9) instrument panel displays the battery charge level and the total number of hours of operation with the brushes engaged.
11. When necessary or to warn of danger use the horn (M15).

### **Stopping the PAS40R**

1. To stop the machine gradually, press the brake pedal (M21).
2. Always engage the parking brake by pressing the pedal (M19) and activate the lever (M20).
3. Remove the key (M7).
4. In the event of problems or short-circuits, press the EMERGENCY button (M6) and contact supplier.

**Note: When the machine is abandoned it switches off automatically, but the parking brake should always be set.**

### **Battery Installation and Charging**

The batteries are supplied separately from the PAS40 and must be inserted into the battery compartment under the lid. The battery charger should be set up in a well-ventilated area, where it is planned to leave the machine for recharging.

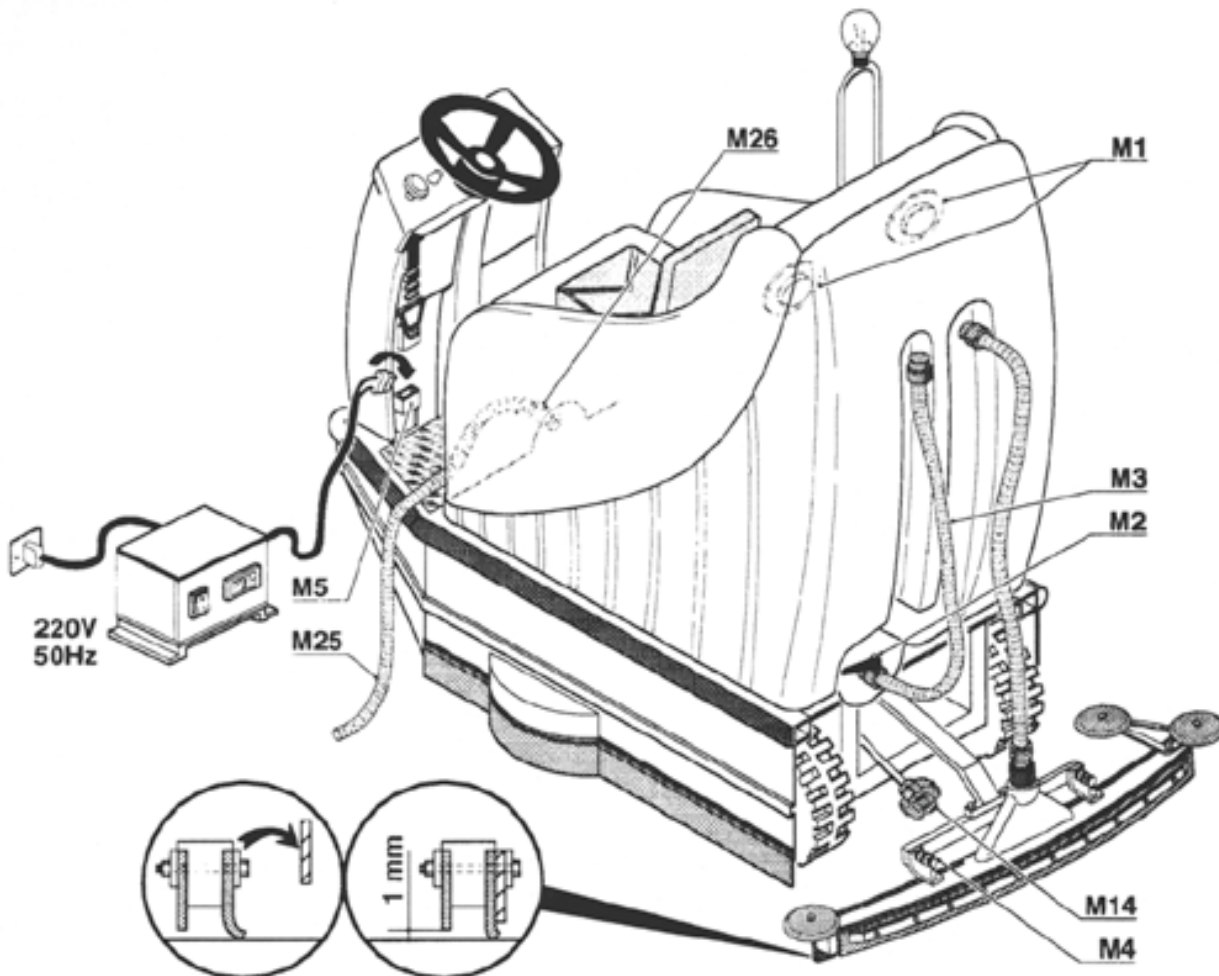

**CAUTION:** Recharging must be done with the cell plugs removed and the cover of the machine open. The recharging process generates gasses, which can be explosive in confined spaces. Only recharge in a well-ventilated area.

**CAUTION:** When working on or around batteries, wear protective clothing and safety glasses. Remove metal jewelry. Do not lay tools or metal objects on top of batteries.

**CAUTION:** Do not smoke or expose open flames or sparks in the vicinity of the batteries (portable grinders, welders, etc.).

**CAUTION:** Do not draw current from the batteries using jumper cables or other forms of temporary connections.

**CAUTION:** Charging batteries generate explosive gasses. **NO SMOKING OR OPEN FLAMES OR SPARKS.** Make sure the charger has turned off before disconnecting it from the batteries. Charge the batteries in a well-ventilated area with the tanks in the raised and locked position.

1. Park the PAS40R on a flat and level floor and engage the parking break.
2. Recharge the batteries in a well-ventilated area and with the cover fixed in the open position.
3. To install the batteries, apply a coating of Vaseline to the terminals and connect the terminals. Make sure the terminals are securely tightened.
4. The charger is provided with a cable for connection to the mains, normally 120 V 50 Hz. Make sure the supply voltage is the same as that indicated on the battery charger itself.
5. To charge the batteries, connect the (M5) connector, which comes directly from the battery compartment, to the battery charger connector.
6. The charger will automatically regulate the charging current and will turn itself off when the batteries are recharged.
7. The charger must be switched off before disconnecting it from the batteries.

### **Solution Tank**

The solution tank is located at the back of the machine. The dual (M1) caps provide easy access for re-filling on either side of the machine. The solution tank capacity is 44 gallons. Use only the quantity and dilution ratios recommended by the chemical supplier and use only non-foaming chemicals.

To completely drain the solution tank, connect the supplied (M25) pipe to the drainage tap (M26). Before filling the solution tank, the recovery tank should be emptied.

### **Recovery Tank**

The recovery tank should be emptied at the end of each job to prevent settling of the recovered waste products. To drain the recovery tank, detach the (M3) pipe at the top and open the rapid drainage tap (M2). Collect the wastewater for disposal in compliance with local environmental protection laws prescribed by the country of use.

### **Wiper Blade**

The floor squeegee serves to finish the drying operation. Level the squeegee into the correct position by using the (M4) knobs so that the black rubber strip is approximately 1 mm (convert) above the floor. For proper drying, it is very important that the squeegee is in the correct position.

The remaining para rubber strips must wipe the floor with a certain amount of pressure. The rubber wipers will adapt themselves, after initial use, to the slope of the surface being cleaned and the drying action will improve.

The pressure of the wipers on the floor is regulated by truning the (M24) knob. When cleaning shiny or smooth floors and when there are holes between tiles, it is advisable not to use the rear (lowest) rubber wiper.

### **Maintenance**

**CAUTION:** Make sure the key switch is turned "OFF" and the battery connector unplugged from the machine before performing any maintenance procedures.

### **Solution Tank**

The solution tank should be cleaned minimally every 6 months. To drain the tank completely, fit the tube (M25) provided to the rapid drainage tap (M26) and open the tap. When all solution is drained, remove the flange (M2) and clean the internal filter (M31).

### **Recovery Tank**

The recovery tank should be emptied after each job. On a weekly basis a more thorough cleaning is required. Remove the motor lock ring (M2) and lift off the suction motor from its seat. Carefully clean the filter, net and sponge, and remove the dirt accumulated in the tank by water jetting. To ease operations detach the discharge assembly (M2) by unscrewing the lateral knobs. Before reassembling, carefully clean the housing of the bi-angular bearing (M29).

NOTE: After every use, flush with clean water to extend life of operating properly

## **Floor Wiper**

Inspect and clean the floor wiper weekly. The wiper assembly should be thoroughly cleaned to provide effective drying. If the drying action is not perfect, remove and replace any worn rubber blades.

## **Brush**

For maximum cleaning results, the brush should be replaced when worn. To remove a worn brush lift the brushes with the regulator (M12) and switch off the machine. Disconnect the battery connector. Remove the key (M7) from the control panel. Using the skirt lock key, unlock the panel, lift the skirt and prop it up on the support rod (M30) provided. Turn the brush to be removed by hand until the coils of spring (M23) are accessible. By closing together the coils of spring (M23) with your fingers (as if you were closing a pair of scissors) the brush will free itself. Replace the brush.

## **Batteries**

Check the electrolyte level on a weekly basis. If the water drops below the level of the battery elements, refill it with distilled water. Keep the batteries clean and dry with anti-static cloths.

Recharging must be done with the cell plugs removed and the cover of the machine open. The recharging process generates gasses, which can be explosive in confined spaces. Only recharge in a well-ventilated area.

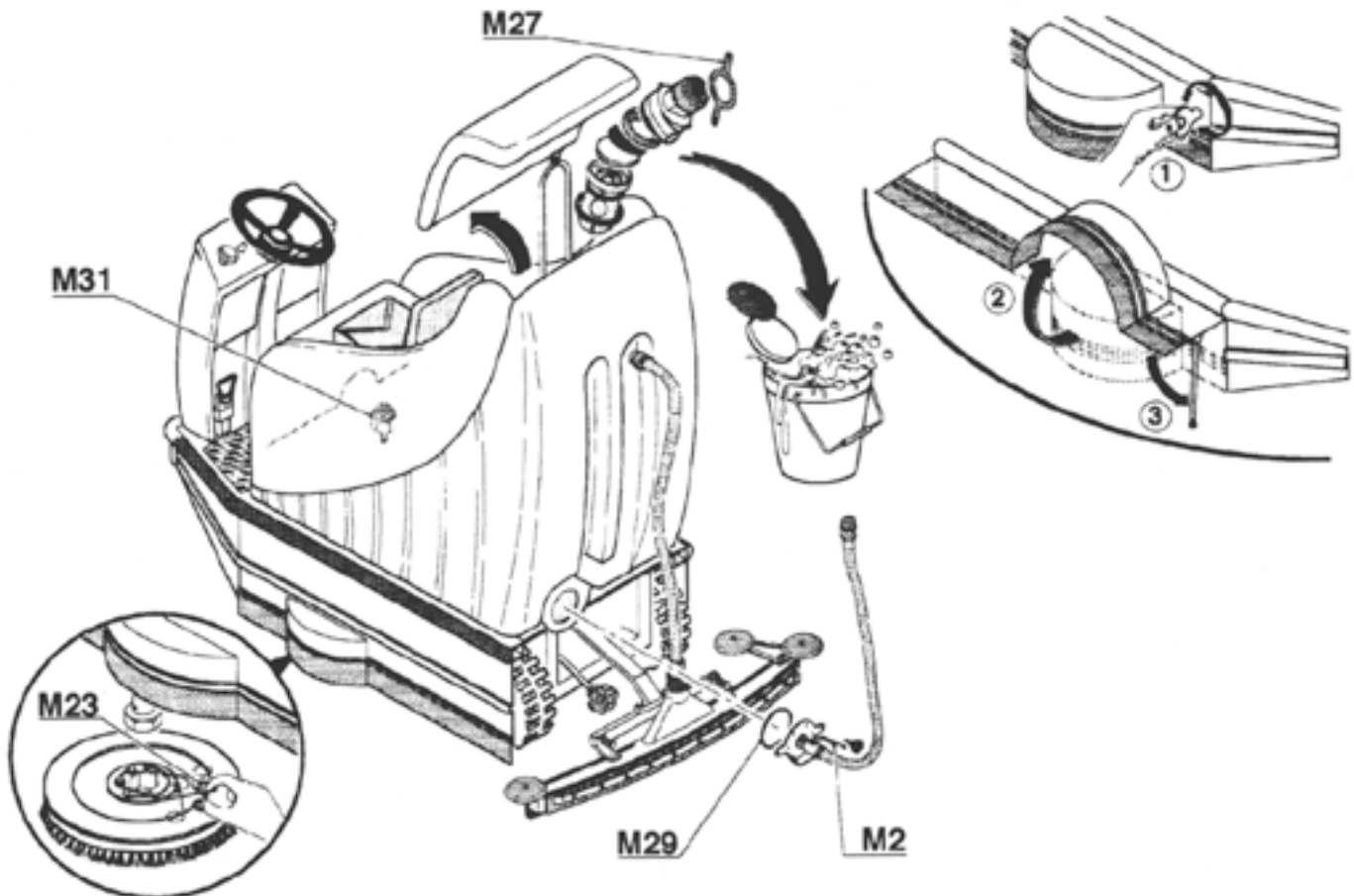
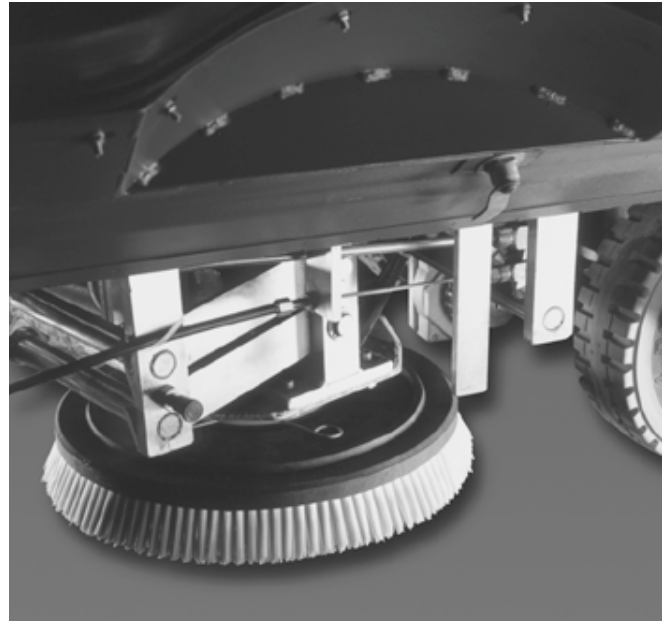

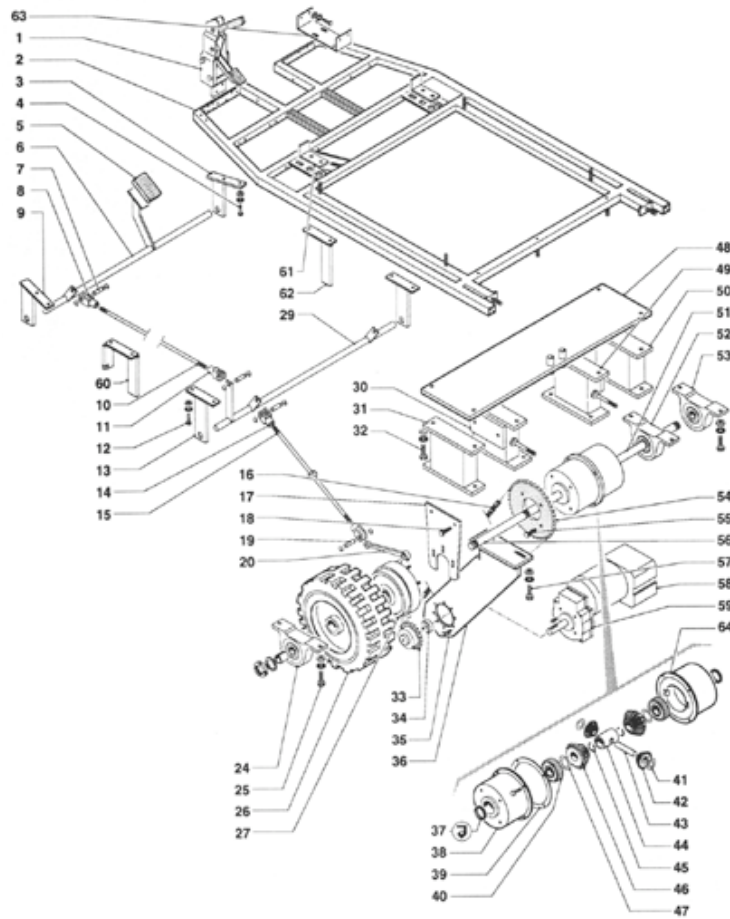

<b>Pos #</b>	<b>Product #</b>	<b>Description</b>
01	PAS410	SUPPORT
02	1000.002	FRAME
03	1000.003	YOKE
04	1000.004	SCREW
05	1000.005	RUBBER
06	1000.006	BRAKE LEVER
07	1000.007	PIN
08	1000.008	FORK
09	1000.009	YOKE
10	1000.010	TIE ROD
11	1000.008	FORK
12	1000.004	SCREW
13	1000.013	YOKE
14	1000.008	FORK
15	PAS411	TIE ROD
16	1000.016	CHAIN
17	1000.017	PLATE
18	1000.018	SCREW
19	1000.007	PIN
20	1000.020	LEVER
24	PAS412	SUPPORT
25	1000.025	SCREW
26	PAS413	WHEEL
27	1000.027	BRAKE
28	1000.013	YOKE
29	1000.029	SHAFT
30	1000.030	SUPPORT
31	1000.031	SUPPORT
32	1000.032	SCREW
33	1000.033	PINION
34	1000.034	SPACER

<b>Pos #</b>	<b>Product #</b>	<b>Description</b>
35	1000.035	SCREW
36	1000.036	PLATE
37	1000.037	SEAL RING
38	1000.038	BELL
39	1000.039	SEAL
40	1000.040	BEARING
41	1000.041	RING
42	1000.042	PLANETARY
43	1000.043	PIN
44	1000.044	SPACER
45	1000.045	STOP
46	1000.046	PUNET GEAR
47	1000.047	RING
48	1000.048	PLATE
49	1000.049	SUPPORT
50	1000.050	SUPPORT
51	1000.051	SHAFT
52	1000.024	SUPPORT
53	1000.024	SUPPORT
54	1000.054	RINGEAR
55	1000.055	SCREW
56	1000.056	SHAFT
57	1000.057	SCREW
58	PAS414	MOTOR
59	1000.059	REDUCTION GEAR
60	1000.060	STOP
61	1000.061	STOP
62	1000.062	STOP
63	1000.063	SUPPORT
64	1000.064	BELL

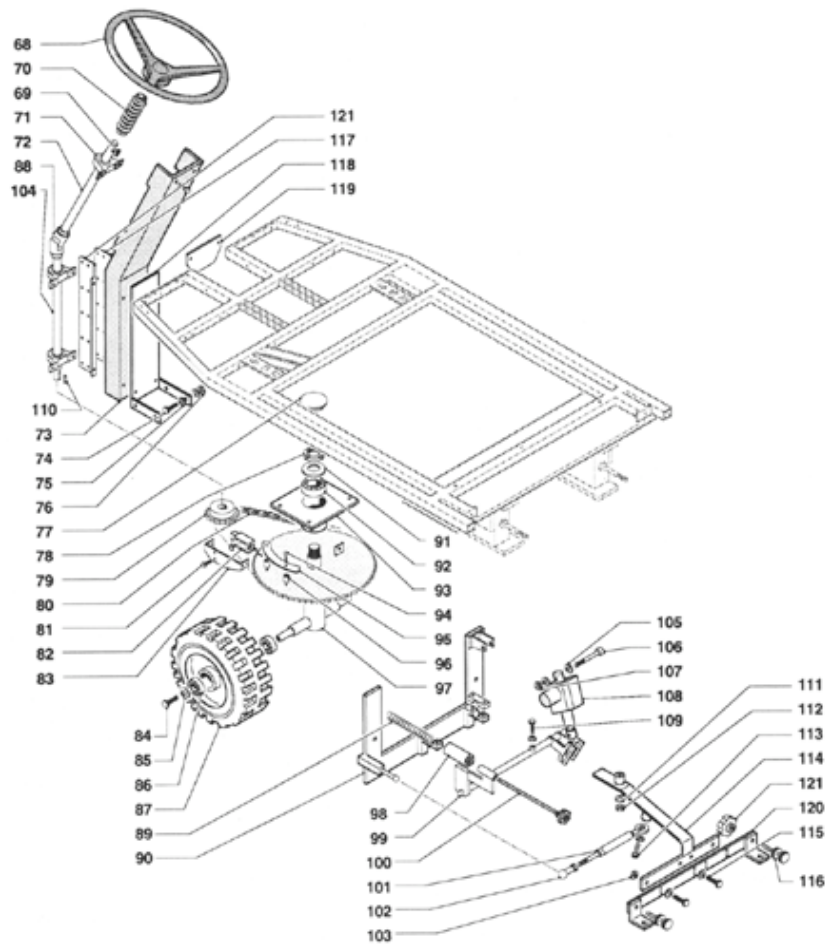

<b>Pos #</b>	<b>Product #</b>	<b>Description</b>
68	1000.068	STEERING WHEEL
69	1000.069	KEY
70	1000.070	SHIELD
71	1000.071	SUPPORT
72	1000.072	SHAFT
73	1000.073	SUPPORT
74	1000.074	SCREW
75	1000.075	WASHER
76	1000.076	NUT
77	1000.077	PLUG
78	1000.078	RING NUT
79	1000.079	PINION
80	PAS415	CHAIN
81	1000.081	SCREW
82	PAS416	LIMIT SWITCH
83	1000.083	YOKE
84	1000.084	SCREW
85	1000.085	WASHER
86	PAS417	BEARING
87	PAS418	WHEEL
88	1000.088	JOINT
89	1000.089	SPRING
90	1000.090	SUPPORT
91	1000.091	RING
92	1000.092	BEARING
93	1000.093	FLANGE
94	1000.094	SCREW

<b>Pos #</b>	<b>Product #</b>	<b>Description</b>
95	1000.095	CAM
96	1000.096	SPACER
97	1000.097	SUPPORT
98	1000.098	STOP
99	PAS419	LEVER
100	PAS420	SCREW
101	PAS421	PISTON
102	PAS422	STOP
103	1000.103	NUT
104	1000.104	SHAFT
105	1000.105	WASHER
106	1000.106	SCREW
107	1000.107	NUT
108	PAS423	ACTUATOR
109	1000.109	SCREW
110	1000.110	KEY
111	1000.111	WASHER
112	1000.112	NUT
113	1000.113	SCREW
114	PAS424	LEVER
115	1000.115	SCREW
116	1000.116	REGULATOR
117	1000.117	PLATE
118	1000.118	PLATE
119	1000.119	PLATE
120	PAS425	SUPPORT
121	S00.223.1	KNOB

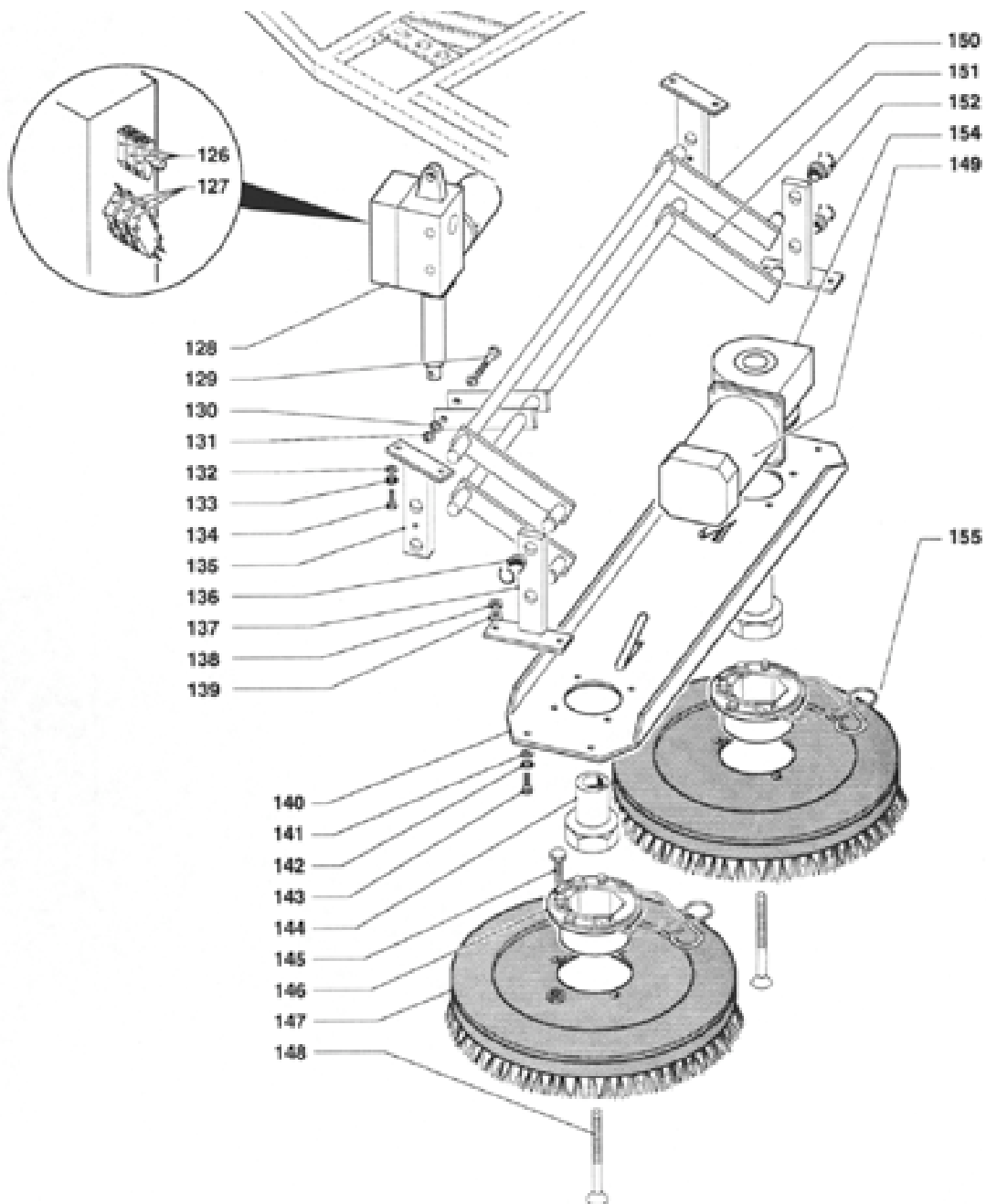

<b>Pos #</b>	<b>Product #</b>	<b>Description</b>
126	PAS426	CAM
127	PAS427	MICRO
128	PAS428	MOTOR
129	1000.129	SCREW
130	1000.130	WASHER
131	1000.131	NUT
132	1000.132	WASHER
133	1000.133	WASHER
134	1000.134	SCREW
135	1000.135	YOKE
136	1000.136	BUSHING
137	1000.137	YOKE
138	1000.138	NUT
139	1000.139	WASHER
140	1000.140	PLATE
141	1000.141	WASHER
142	10.00.142	WASHER
143	1000.143	SCREW

<b>Pos #</b>	<b>Product #</b>	<b>Description</b>
144	PAS429	COUPLING
145	1000.145	SCREW
146	PAS6	SUPPORT WITH SPRING
147	PAS600	20" PAD DRIVER
147	PAS601	19" POLY STIFF BRUSH
147	PAS602	19" POWER-SCUFF BRUSH
147	PAS603	19" POWER SCRUB II BRUSH
147	PAS604	19" POWER NYLON BRUSH
147	PAS605	19" STRATA BRIT BRUSH
148	1000.148	SCREW
149	PAS430	MOTOR
150	1000.150	LEVER
151	1000.151	LEVER
152	1000.152	BUSHING
154	PAS431	REDUCTION GEAR
155	PAS7	SPRING

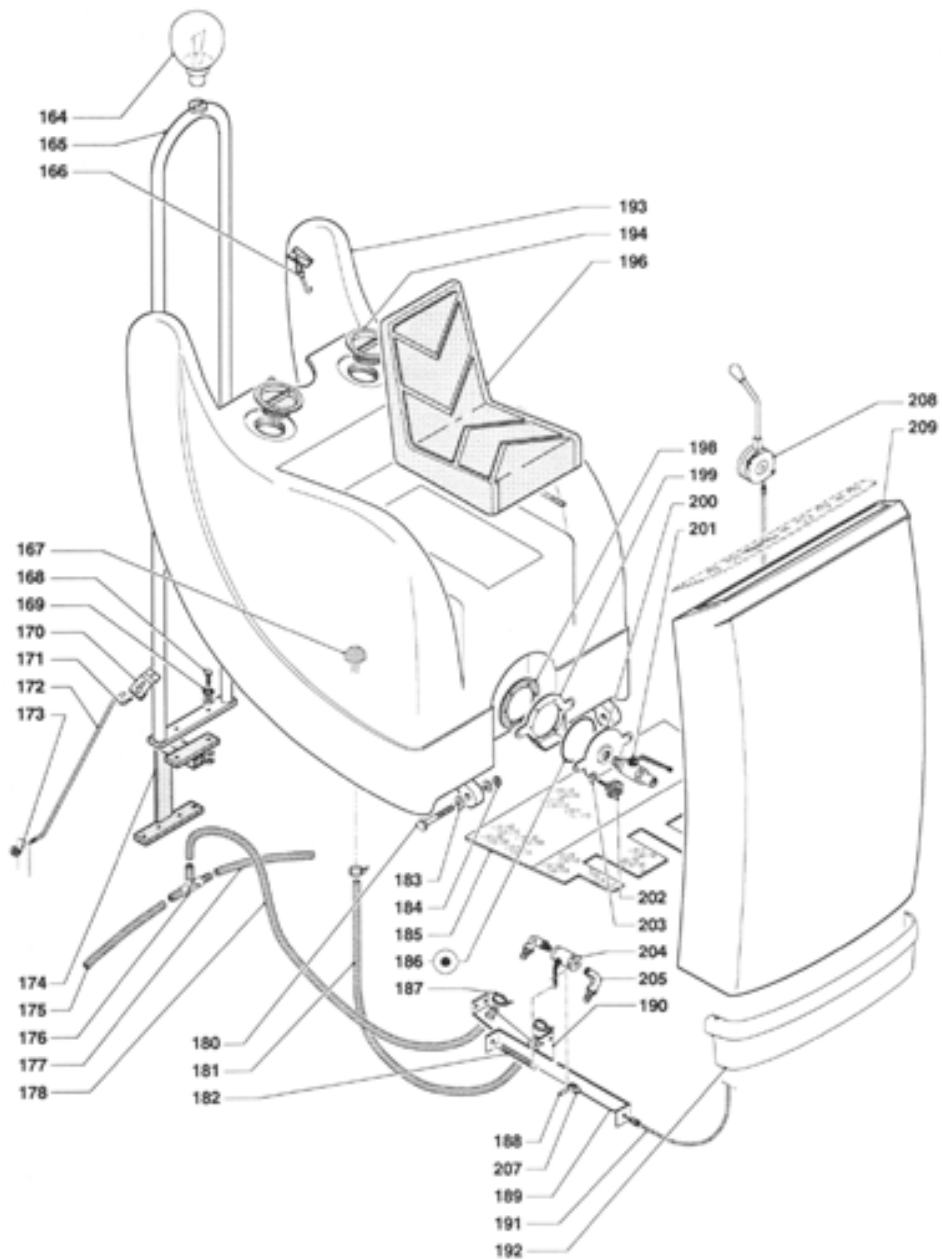

<b>Pos #</b>	<b>Product #</b>	<b>Description</b>
164	PAS432	LAMP
165	1000.165	LAMP HOLDER
166	PAS433	HOOK
167	PAS3	FILTER
168	1000.168	SCREW
169	1000.169	WASHER
170	1000.170	PLATE
171	1000.171	SCREW
172	PAS434	ROD
173	1000.173	NUT
174	1000.174	SUPPORT
175	1000.175	RUBBER TUBE
176	PAS435	HOSE FITTING
177	1000.177	RUBBER TUBE
178	PAS436	RUBBER TUBE
180	1000.180	SCREW
181	1000.181	QUICK CONNECTION
182	1000.1A7	SPRING
183	1000.183	WASHER
184	1000.184	NUT
185	1000.185	FLOOR PLATES

<b>Pos #</b>	<b>Product #</b>	<b>Description</b>
186	500.083.1	SEAL
187	1000.187	HOSE COLLARS
188	1000.188	PIN
189	PAS168	WIRE
191	PAS171	SHEATHING
192	1000.192	SHIELD
193	1000.193	TANK
194	1000.194	PLUG
196	1000.196	SEAT
198	500.078	SEAL
199	500.079.1	FIXED FLANGE
200	500.089.1	MOVABLE FLANGE
201	PAS75	BALL VALVE
202	PAS74	KNOB
203	500.085	WASHER
204	PAS437	BALL VALVE
205	1000.205	HOSE FITTING
206	PAS438	YOKE
207	1000.207	FORK
208	1000.208	METERING DEVICE
209	1W0.209	CHEST

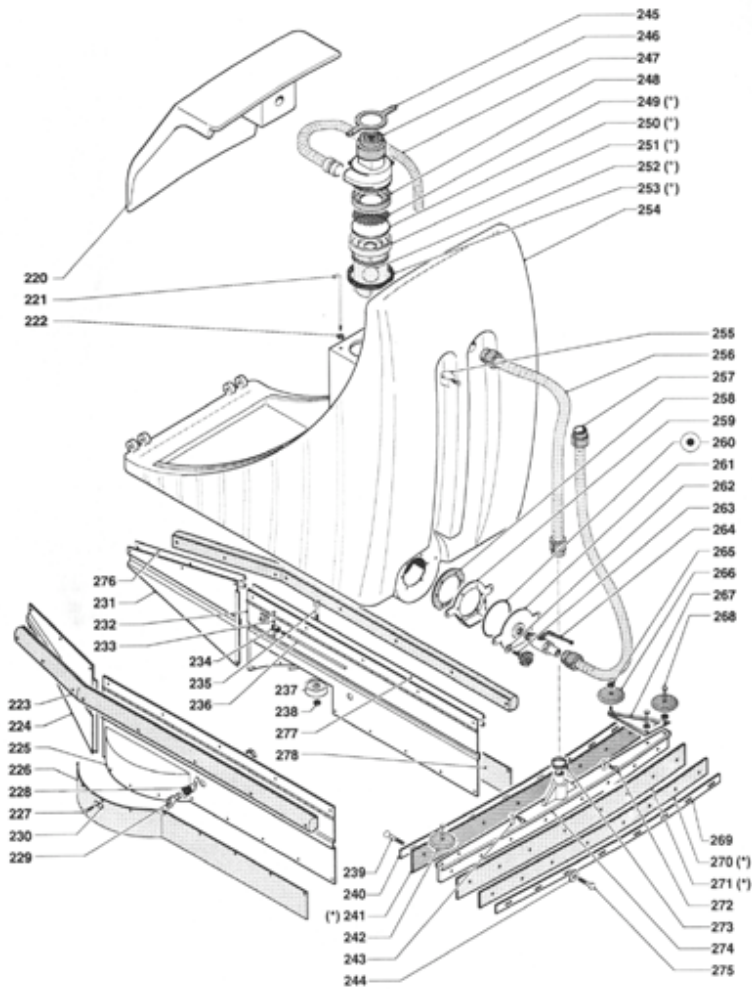

<b>Pos #</b>	<b>Product #</b>	<b>Description</b>
(°)	1000.276	COMPLETE FLOAT LEVEL
(*)	1000.277	KIT RUBBER
220	1000.220	CHEST
221	401.105	TIE ROD
222	430 070	NUT
223	1000.223	RUBBER
224	1000.224	CASING
225	1000.225	CASING
226	PAS439	SPLASH GUARD
227	1000.227	RUBBER
228	PAS179	KEY ASSY FOR PAD SHROUD
229	PAS179	KEY ASSY FOR PAD SHROUD
230	1000.230	WASHER
231	1000.231	KEY FOSSY FOR PAD SHROUD
232	1000.232	KEY FOSSY FOR PAD SHROUD
233	1000.233	PIN
234	1000.234	FORK
235	1000.235	SCREW
236	1000.236	ROD
237	1000.237	WHEEL
238	1000.238	NUT
239	PAS223	SCREW
240	PAS938	FRONT STRIP
241	PAS931	BLACK RUBBER
242	PAS1	BUFFER WHEEL
243	PAS942	SUPPORT STUD
244	PAS941	WASHER
245	PAS15	STRAP
246	850.247	MOTOR
247	PAS37	DRAIN HOSE

<b>Pos #</b>	<b>Product #</b>	<b>Description</b>
248	PAS102	SEAL
249	06.169	FILTER
250	500.069	SPONGE
251	PAS85	SUPPORT
252	PAS210	FLOAT LEVEL
253	PAS103	SEAL
254	1000.254	TANK
255	1000.255	PIPE STRAP
256	PAS80	SUCTION PIPE
257	1000.257	PIPE
258	PAS70	SEAL
259	PAS440	FIXED FLANGE
260	PAS441	SEAL
261	PAS442	MOVABLE FLANGE
262	PAS186	WASHER
263	PAS74	KNOB
264	PAS75	BALL VALVE
265	PAS935	NUT
266	PAS1	BUFFER WHEEL
267	PAS182	SUPPORT
268	PAS936	SCREW
269	PAS940	BACK STRIP
270	PAS939	CREPE RUBBER
271	PAS933	CREPE RUBBER
272	PAS959	SPLIT PIN
273	PAS191	HOSE COLLARS
274	PAS932	FLOOR WASHING BODY
275	PAS223	SCREW
276	1000.276	GUIDE
277	1000.277	GUIDE
278	1000.278	SPLASH GUARD

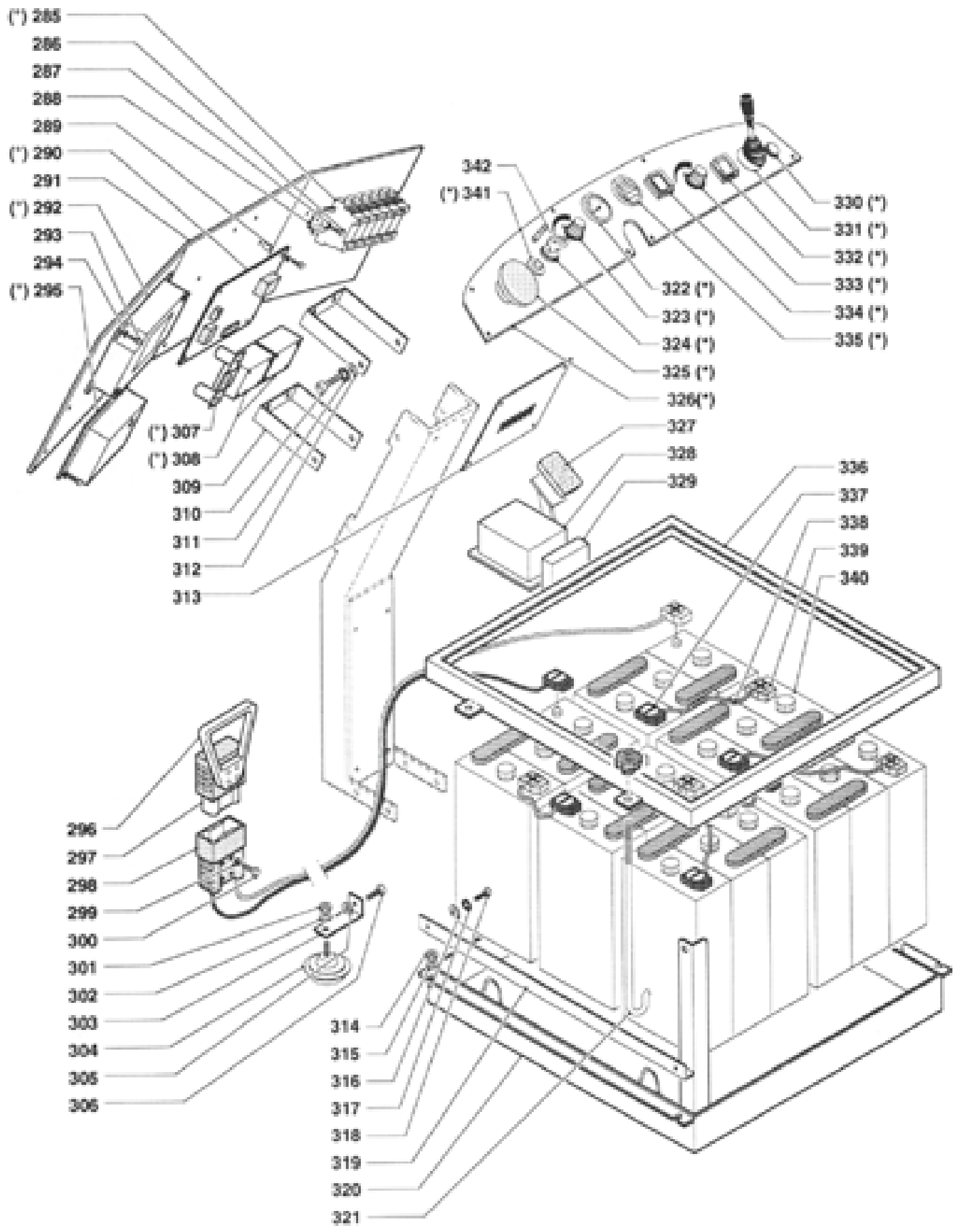

<b>Pos #</b>	<b>Product #</b>	<b>Description</b>
(°)	1000.341	ELECTRIC PLANT
(*)	1000.342	PANEL PLANT
285	PAS954	FUSE HOLDER
286	1000.286	SCREW
287	1000.287	WASHER
288	1000.288	SLIDE
289	1000.289	SPACER
290	PAS443	ELECTRONIC CARD
291	1000.291	SUPPORT
292	PAS444	TRACTION CARD
293	1000.293	SCREW
294	1000.294	WASHER
295	PAS445	JACK CARD
296	PAS446	HANDLE
297	PAS447	FASTENER
298	1000.298	PIN
299	1000.299	WASHER
300	1000.300	SCREW
301	1000.301	NUT
302	1000.302	WASHER
303	1000.303	SQUARE
304	1000.304	HORN
305	1000.305	NUT
306	1000.306	SCREW
307	PAS448	FUSE
308	PAS449	CONDENSER
309	1000.309	YOKE
310	1000.310	SCREW
311	1000.311	WASHER
312	1000.312	WASHER
313	1000.313	PLATE

<b>Pos #</b>	<b>Product #</b>	<b>Description</b>
314	1000.314	NUT
315	1000.315	WASHER
315	1000.316	WASHER
317	1000.317	WASHER
318	1000.318	SCREW
319	1000.319	STOP STRIP
320	1000.320	SUPPORT
321	1000.321	TIE ROD
322	1000.322	HOUR COUNTER
323	PAS450	POTENTIOMETER
324	PAS53NS	MASTER SWITCH/KEY
324A	PAS53KNS	KEY
325	1000.325	PUSH BUTTON
326	1000.326	ELECTRIC PANEL
327	1000.327	RUBBER
328	PAS451	LINKAGE
329	1000.329	BUZZER
330	1000.330	PUSH BUTTON
331	PAS452	LEVER
322	PAS54	SWITCH
333	PAS4536	SWITCH
334	PAS454	POTENTIOMETER
335	1000.335	AMMETER
336	1000.336	BLOCK
337	1000.337	CLAMP
338	1000.338	CABLE
339	1000.339	CLAMP
340	1000.340	HOSE BATTERY
340	1000.332.1	ARMATURE BATTERY
340	1000.332.2	PLATE BATTERY
341	1000.341	FUSE HOLDER

**TECHNICAL CHARACTERISTICS**  
**POWR-FLITE PREDATOR 40" AUTOSCRUBBER MODEL PAS40R**

Area per hour . . . . .	64,000 sq. ft. . . . .	5,945 sq. meters
Solution tank . . . . .	45 gallons . . . . .	170 liters
Recovery tank . . . . .	45 gallons . . . . .	170 liters
Cleaning width . . . . .	40 inches . . . . .	101.6 cm
Squeegee Width . . . . .	46 inches . . . . .	116.8 cm
Brush pressure . . . . .	200 lbs. - 400 lbs. . . . .	91 kg - 181 kg
Brush speed . . . . .	225 rpm . . . . .	225 rpm
Brushes . . . . .	2 ea. 20 inch . . . . .	2 x 50.8 cm
Brush motor . . . . .	2 ea. 3/4 hp . . . . .	2 ea. 3/4 hp
Brush pressure motor . . . . .	1-1/4 hp . . . . .	1-1/4 hp
Vacuum motor . . . . .	2 ea. 1/2 hp, 3 stage by-pass . . . . .	2 ea. 1/2hp, 3 stage by-pass
Drive motor System . . . . .	Transverse . . . . .	Transverse
Supply voltage . . . . .	36 volt . . . . .	36 volt
Continuous Run Time . . . . .	4 - 6 hours . . . . .	6 hours
Operating time . . . . .	6 - 8 hours . . . . .	6 - 8 hours
Battery requirement . . . . .	6 - 6 volt- 244 ah . . . . .	6 - 6 volt- 244 ah
Weight . . . . .	880 lbs w/o batteries . . . . .	400 kgs. w/o batteries
Dimensions . . . . .	70.8" L x 41.3" W x 67" H . . . . .	179.8 cm L x 105 cm W x 170 cm H



A Tacony Company  
3101 Wichita Court • Ft. Worth, TX 76140-1710