

Predator Automatic Scrubber 32

OPERATORS MANUAL AND PARTS LIST

Model PAS32SHP



Contains drawings for all PAS32SHP models to date

WARNING: OPERATOR MUST READ AND UNDERSTAND THIS MANUAL COMPLETELY BEFORE OPERATING THIS EQUIPMENT.

TECHNICAL CHARACTERISTICS

POWR-FLITE PREDATOR 32" AUTOSCRUBBER MODEL PAS32SHP

Area per hour	54,000 sq. ft.	5016 sq. meters
Solution tank	24 gallons	100 liters
Recovery tank	24 gallons	100 liters
Cleaning width	32 inches	812 mm
Squeegee Width	44 inches	1117 mm
Brush pressure	88 lbs. - 175 lbs.	40kg - 80kg
Brush speed	225 rpm	225 rpm
Brushes	2 ea. 16 inch	2 x 406 mm
Brush motor	2 ea. 3/4 hp	2 ea. 3/4 hp
Brush pressure motor	1-1/4 hp	1-1/4 hp
Vacuum motor	2 ea. 1/2 hp	2 ea. 1/2hp
Drive motor	1/2 hp.	1/2 hp.
Transmission	helical gear	helical gear
Supply voltage	36 volt	36 volt
Continuous operating	6 hours	6 hours
Operating time	6 - 8 hours	6 - 8 hours
Battery requirement	6 - 6 volt- 244 ah	6 - 6 volt- 244 ah
Battery storage area LxWxH	21-1/4 x 21-1/2 x 14 1/8	53.9 cm x 54.6 cm x 35.9 cm
Weight w/o batteries	440 lbs.	200 kgs.

IMPORTANT SAFETY INSTRUCTIONS

All operators must read, understand and practice the following safety instructions.

They will be repeated occasionally throughout this manual, and additional cautions may be added for specific causes.

- **CAUTION:** Operators must read and understand this manual completely before operating this equipment.
- **CAUTION:** Make sure key switch is in the "OFF" position before installing pad.
- **CAUTION:** Loose objects on the floor can become dangerous projectiles if struck by the high-speed pad. Remove them before operating this machine.
- **CAUTION:** Keep hands and feet away from revolving pad.
- **CAUTION:** Keep machine moving to prevent damage to finish or floor.
- **CAUTION:** Make sure key switch is turned "OFF" and battery connector is unplugged from machine before performing any maintenance procedures.
- **CAUTION:** Maintenance and repairs must be performed by authorized personnel.
- **CAUTION:** Battery acid can cause burns. When working on or around batteries, wear protective clothing and safety glasses. Remove metal jewelry. Do not lay tools or metal objects on top of batteries.
- **CAUTION:** Do not operate this equipment in bare feet or with open-toed shoes or sandals.
- **CAUTION:** Charging batteries generate explosive gases. ***NO SMOKING OR OPEN FLAMES OR SPARKS.*** Make sure the charger has turned off before disconnecting it from the batteries. Charge batteries in a well-ventilated area with the tanks in the raised and locked position.
- **CAUTION:** Store or park this machine on a level surface only. Remove key from switch if machine is left unattended.
- **CAUTION:** Do not operate machine or charger in areas where flammable liquids or gases are present. Do not use or pick up flammable chemicals or liquids with this machine.
- **CAUTION:** Make sure all caution, warning and instructional decals are in place and legible. Replace damaged or missing labels.
- **CAUTION:** These machines are designed for level floor operations only. ***DO NOT OPERATE ON RAMPS OR INCLINES*** unless adequate personnel are available for assistance.
- **CAUTION:** Do not expose electrical components to water or other liquids. To clean machine wipe down with a damp cloth.

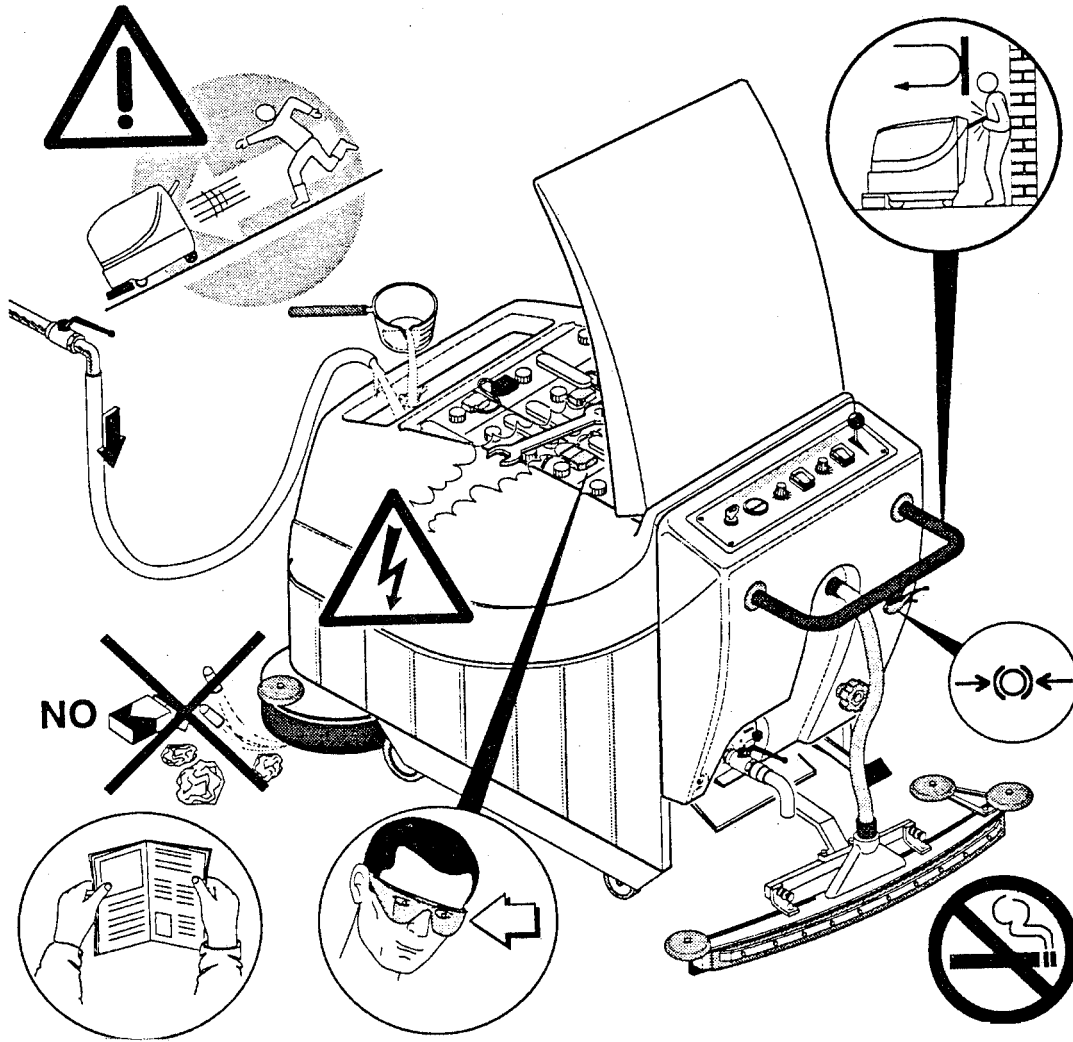

WARNING! Do not operate machine or charger in areas where flammable liquids or gases are present. Do not use or pick up flammable chemicals or liquids with this machine.

CAUTION: Make sure all caution, warning and instructional decals are in place and legible. Replace damaged or missing labels.

This autoscrubber has been designed to the strictest safety standards but the user must still use the machine with care and caution.

Here are a few rules which must be respected:

- Never leave the machine unattended, particularly when there are children around.
- Always switch off the machine when filling the solution tank.
- Never attempt to make emergency repairs or use non-original spare parts.
- Engage the safety brake every time the machine is left unattended.
- Remove the on/off key every time the machine is left unattended.
- Check the wear and deterioration of the materials at intervals and ask the seller for assistance.
- Do not smoke or expose open flames or sparks in the vicinity of the batteries (*portable grinders, welders, etc.*).
- Do not take current from the batteries using jumper cables or other forms of temporary connections.
- Do not rest metal tools or instruments on the of the risk of electric shock or burns if the battery posts' are shorted.

POWR-FLITE PREDATOR 32 AUTOMATIC SCRUBBER

This manual refers to a battery powered automatic floor scrubber. Designed to be simple, easy to operate and safe, with maneuverability and automatic variable electronic drive and electronically controlled pad pressure. Routine maintenance has been simplified and reduced to the minimum to keep equipment on the job.

THE BASIC DESCRIPTION OF THE MACHINE CAN BE SUMMED UP BY THE FOLLOWING FEATURES:

1. Sealed ball-bearing wheels - maintenance free with polyurethane covered cast iron wheels.
2. Independent drive system, totally enclosed motor, direct drive, dual wheel drive for superior traction.
3. State of the art, soft start offers full range and variable drive powered by fully lubricated sealed forward and reverse drive motor.
4. Piston driven pad pressure with electronic control.
5. From safety & theft-proof position, control panel equipped with key for "on/off" prevents unauthorized operation.
6. Hospital quiet, reduced noise level less than 80 dB.
7. Dual vacuum motors can be operated single or parallel for additional airflow.
8. High-speed brush drive with electronically controlled variable pad pressure 88-175 lbs. of contouring pad pressure prevents streaking and produces high productivity with 2 independently operating geared motors.
9. Solution control conveniently located with ease of operation and dispensing control...user friendly..
10. Increased working capacity and productivity offered by higher brush drive speed, increased full contouring pad pressure and operation fatigue eliminating drive system.
11. 8 year warranty on housing and tanks
5 year warranty on frame
1 year warranty on motors
12. Rotationally molded design for housing, skirt and tank provide lighter weight, chemical resistance and styling features.
13. Design prevents solution contamination with serviceable access to the solution & recovery tanks.
14. Curved aluminum squeegee body with reversible rubber squeegees.
15. Easy "Safe" access to drive brushes for pad or brush removal without requiring tilting of the unit to rear.
16. Squeegee design provides smooth follow operation when cleaning along walls and making runs. The concave squeegee allows maximum pick-up without streaking.
17. Safety automatic "reverse to forward" switch system to prevent injury.
18. Formed one piece welded steel zinc-plated frame.
19. All steel brush housing with baked enamel finish.
20. Vinyl splash guard will not corrode.
21. Parking and safety brake.
22. The upper housing has a hinged open feature for easy battery and motor access.
23. Large dump valve and sludge door for fast clean out.

WARNING:

DO NOT OPERATE MACHINE OR CHARGER IN AREAS WHERE FLAMMABLE LIQUIDS OR GASES ARE PRESENT.

DO NOT USE OR PICK UP FLAMMABLE CHEMICALS OR LIQUIDS WITH THIS MACHINE.

The objective of this manual is to ensure that the machine is operated correctly and performs the service of cleaning level floor surfaces. Therefore, we advise **you to follow the instructions it contains scrupulously** since the manufacturer accepts no responsibility for damage to persons, or things, or damage to the machine if the machine is not operated the way described in this manual or if the maintenance and safety instructions are not fully complied with.

The instructions provided in this manual do not replace the safety instructions and technical data for installation and operation directly applied on the product, nor do they replace the safety standards current in the country of installation and the rules dictated by normal common sense.

The operator or maintenance worker must advise a person in authority of any faults or deterioration which could affect the original safety of the machine.

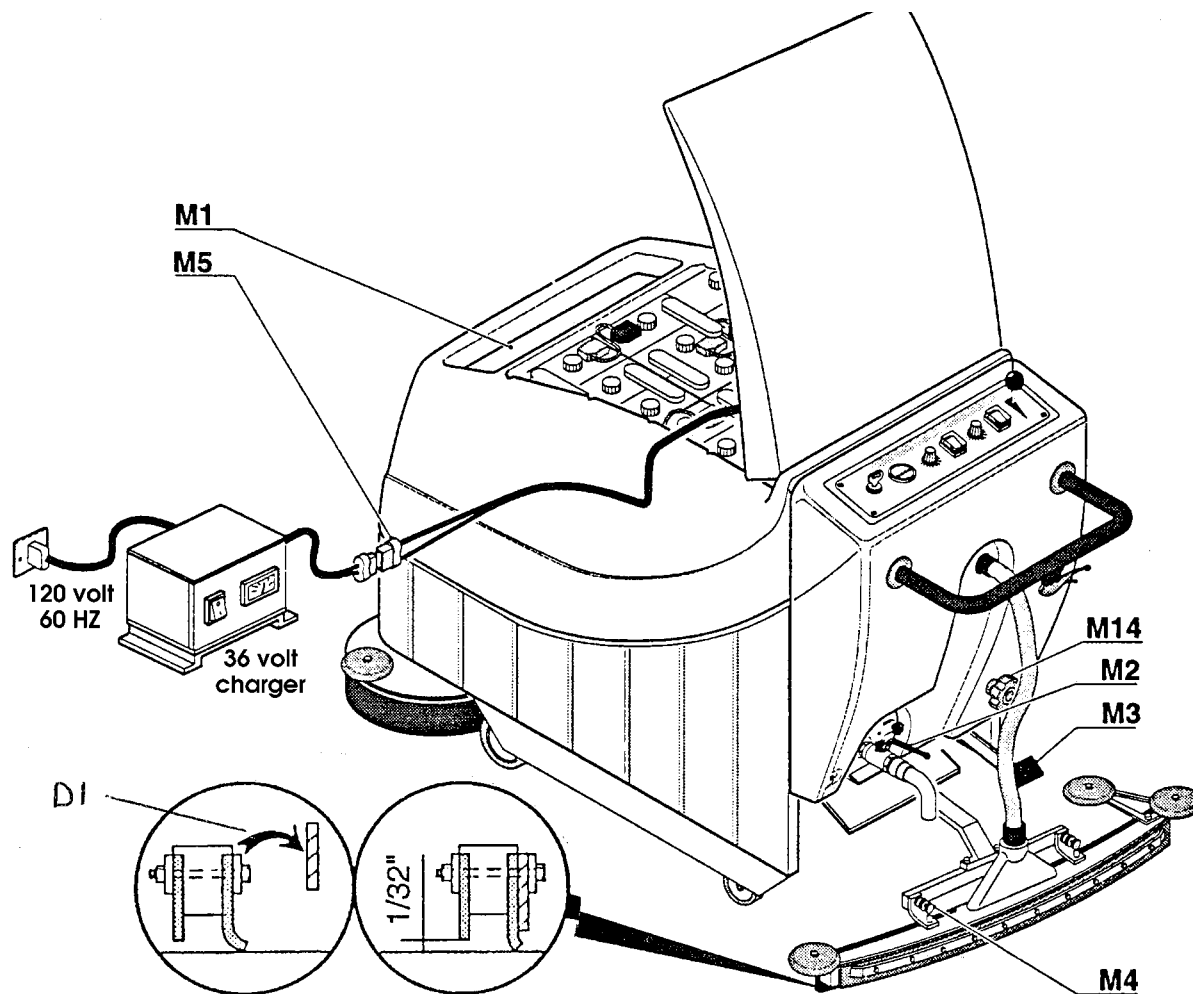

Solution Tank: The solution tank is located under the lid, at the front of the machine, with the filling-funnel **M1** in an accessible position for easy re-filling.

Note: Always empty the dirty water collection tank, as described in the next paragraph, before refilling the tank with the diluted detergent solution. The solution tank has a maximum capacity of 24 gallons (100 liters). Always use the products and the dilution quantities recommended by the seller. The solution tank may be drained by removing the plug on the bottom left side of the tank or by vacuuming the solution out into the dirty water tank with a 1-1/2 " vacuum hose attached where the squeegee hose normally fits. Never use foamy detergents. Use defoamer if excess foam develops.

Water collection tank: The dirty water collection tank should be emptied, preferably each time after use, so that the dirt does not settle there. To do this, open the ball valve **M2**, emptying dirty water into the proper drain conforming to local regulations. For sludge clean-out, open the port by loosening both knobs.

Squeegee: The squeegee has the final task of completing the drying of the floor and it is very important for it to be in the correct position. Lower the squeegee to the working position by pressing pedal **M3**. Adjust the position of the squeegee by means of the knobs **M4** so that the black rubber bar is about 1/32" (the thickness of a business card) from the floor. The squeegee behind this is in natural rubber and must press on the floor with a certain amount of force. **After the first few hours the squeegee adjusts itself to the correct angle and drying becomes even better.** Squeegee pressure is

adjusted by knob **M14**. When cleaning very shiny, smooth or floors with grout removal of the rear (shorter) squeegee blade is recommended.

Battery installation and charging: The batteries must be inserted in the special compartment provided under the lid. Apply a layer of vaseline to the terminals and connect in series as shown on page 18. Make sure that the terminals are correctly tightened. The battery charger must be installed in a well ventilated place where it is planned to leave the machine. The charger is provided with a cable for connection to the mains, normally **120v/60HZ**. Check that the voltage corresponds to the voltage indicated on the battery charger. Do not use an extension cord to power the charger. To charge the batteries, connect the connector of the machine batteries **M5** to the connector of the battery charger. The Powr-Flite battery charger will automatically regulate the voltage to the batteries and will switch itself off when the batteries have been fully charged.

CAUTION: **A)** Make sure key switch is turned "OFF" and battery connector is unplugged from machine before performing any maintenance procedures. **B)** Battery acid can cause burns. When working on or around batteries, wear protective clothing and safety glasses. Remove metal jewelry. Do not lay tools or metal objects on top of batteries. **C)** Charging batteries give off explosive fumes and harmful (corrosive) fumes.

NO SMOKING OR OPEN FLAMES OR SPARKS. Make sure the charger has turned off before disconnecting it from the batteries. Charge batteries in a well-ventilated area with the lid raised and in locked position while the batteries are charging.

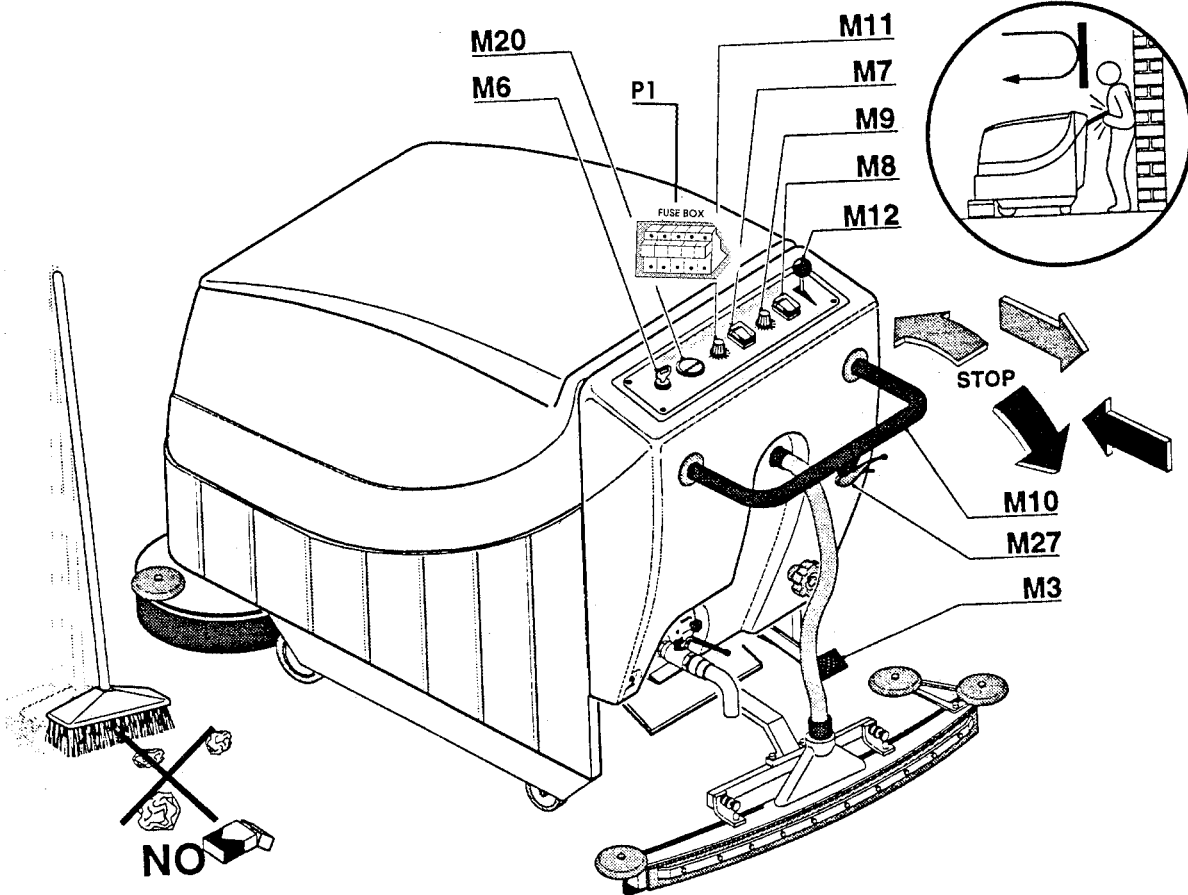

The area to be scrubbed: Debris and grit must be swept up before starting the scrubbing operation to avoid vacuum line blockage and to permit the detergent to perform efficiently.

Starting up and operation: Disconnect the batteries from the battery charger and connect to the machine. Then:

- Turn master switch **M6** to position 1 and press switches **M7** and **M8**.
- Lower the brushes by turning knob **M9** clockwise. Maximum setting is #10. Only use the pressure setting that effectively performs the cleaning desired for the longest run time and fastest operation.
- Lower the squeegee by pressing pedal **M3**.
- Set the detergent solution supply to minimum by raising the adjusting knob **M12**.
- Release the brake by squeezing the small lever.
- Press down the handle **M10** to drive forward. When the handle is released the machine stops.
- Adjust the speed of advance by adjusting knob **M11**.
- Finally, adjust the correct supply of the detergent in relation to the amount of dirt and speed of advance by means of lever **M12**; this is a matter of experience.

At this point the machine is ready to carry out the operations of scrubbing and drying at the same time. Single vacuum motor operation may be all that is necessary for daily scrubbing. To operate one vacuum open and lock the autoscrubber lid. Locate the fuse panel **P1** attached to the back frame behind the vacuum motors. Pull and open the first fuse door from the left side of the fuse housing bank.

CAUTION: Make sure key switch is in the "OFF" position before installing pad.

Particularly dirty floors: Certain floors or areas may require special attention and, in some cases, cleaning twice. Go over the floor quickly the first time, with the squeegee raised and the brush in the working position. In this way, the detergent solution is left on the floor for a longer time and can dissolve the heavy dirt. The second time, go over the floor more slowly with both the brush and the squeegee lowered.

CAUTION: A) Loose objects on the floor can become dangerous projectiles if struck by the high-speed pad. Remove them before operating this machine. **B)** Keep machine moving to prevent damage to finish or floor. **C)** These machines are designed for level floor operations only. **DO NOT OPERATE ON RAMPS OR INCLINES greater than 2% grade** unless adequate personnel are available for assistance.

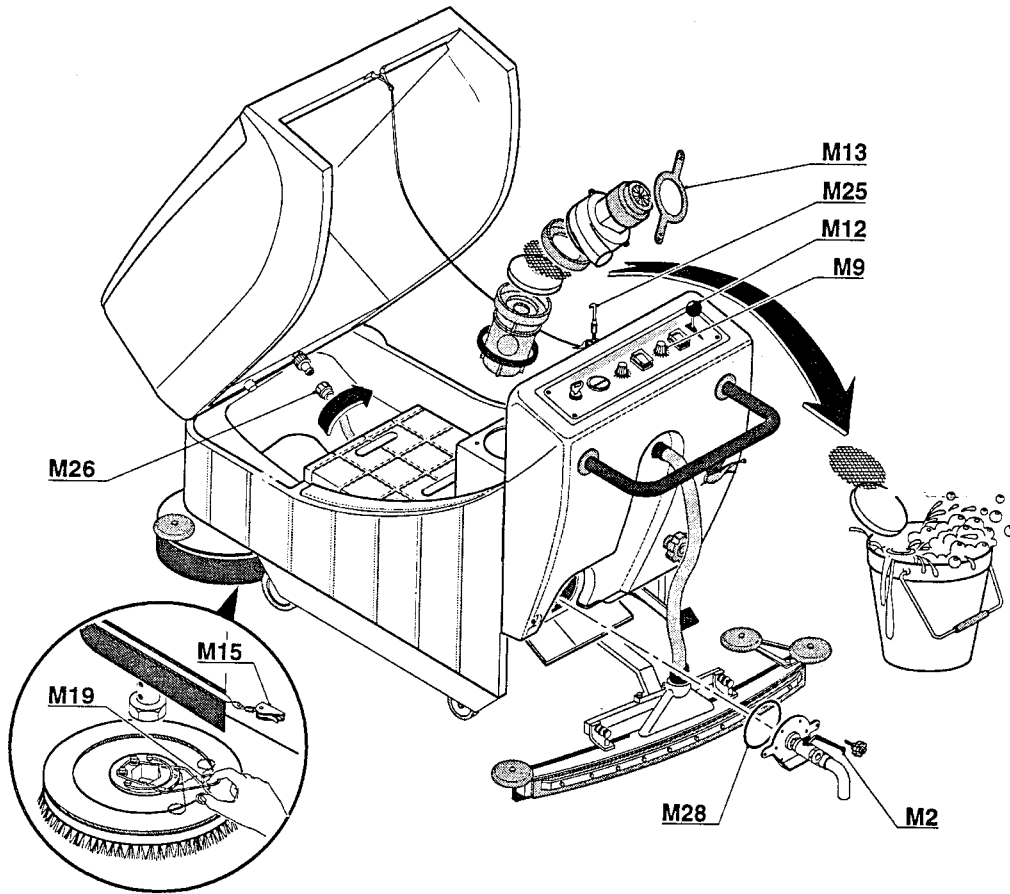

Squeegee: Every week, check the blades of the squeegee and wash them carefully. Then replace them in the correct working position (*see above*). If drying is not perfect even after the unit has been cleaned, replace any blades which are excessively worn. If the squeegee does not pick up enough water or streaks, lift and wipe off the blades. Inspect the squeegee vacuum path for obstructions.

The pad driver or brush must be in good working condition because it is the component which removes the dirt.

To replace the block, pad or brush:

- Turn off the machine by placing the key in the off position
- Lift the brush up by turning the knob **M9** to the off "O" position
- Open the spring lever **M15** or fold up the vinyl splash guard. Access from your right side, facing the front of the scrubber.
- Rotate the brush by hand until the **M19** spring rings are reached. Closing the **M19** spring rings together by fingers (*like scissors*) drops the brush.
- Rotate driver/brush 180° and firmly pull it out from the scrubber.

A selection of brushes for specific purposes is available. Pad drivers should be installed with the chosen pad. **Black** for stripping, **Green** for deep scrub, **Blue** for cleansing and **Red** for light scrub.

Water collection tank: This tank should be cleaned every week.

- 1) Lift and lock the lid.
- 2) Remove the vacuum motor straps **M13** and lift the vacuum motors out.
- 3) Thoroughly clean the filter or replace with a new filter.
- 4) Remove the float cage assembly and clean off the float ball and assembly. Inspect free movement of the float ball.
- 5) Thoroughly flush out the tank by spraying water into the tank through the openings allowing the drainage through the valve or sludge port **M2**. The sludge door may be removed by unscrewing the 2 knobs.
- 6) Before replacing the door clean the door housing and the gasket **M28**.
- 7) Carefully replace all components and make sure the gaskets are seated.

Batteries: Check the level of the electrolyte liquid by carefully removing plugs from top of battery and topping off with distilled water, when the level drops below the plates of the battery. Keep the batteries clean and dry with antistatic cloths. When charging the batteries lift the top lid of the machine to allow the gas which is generated to escape. **This gas can cause explosions in closed environments** and, therefore, it is advisable to carry out battery charging in well-ventilated environments.

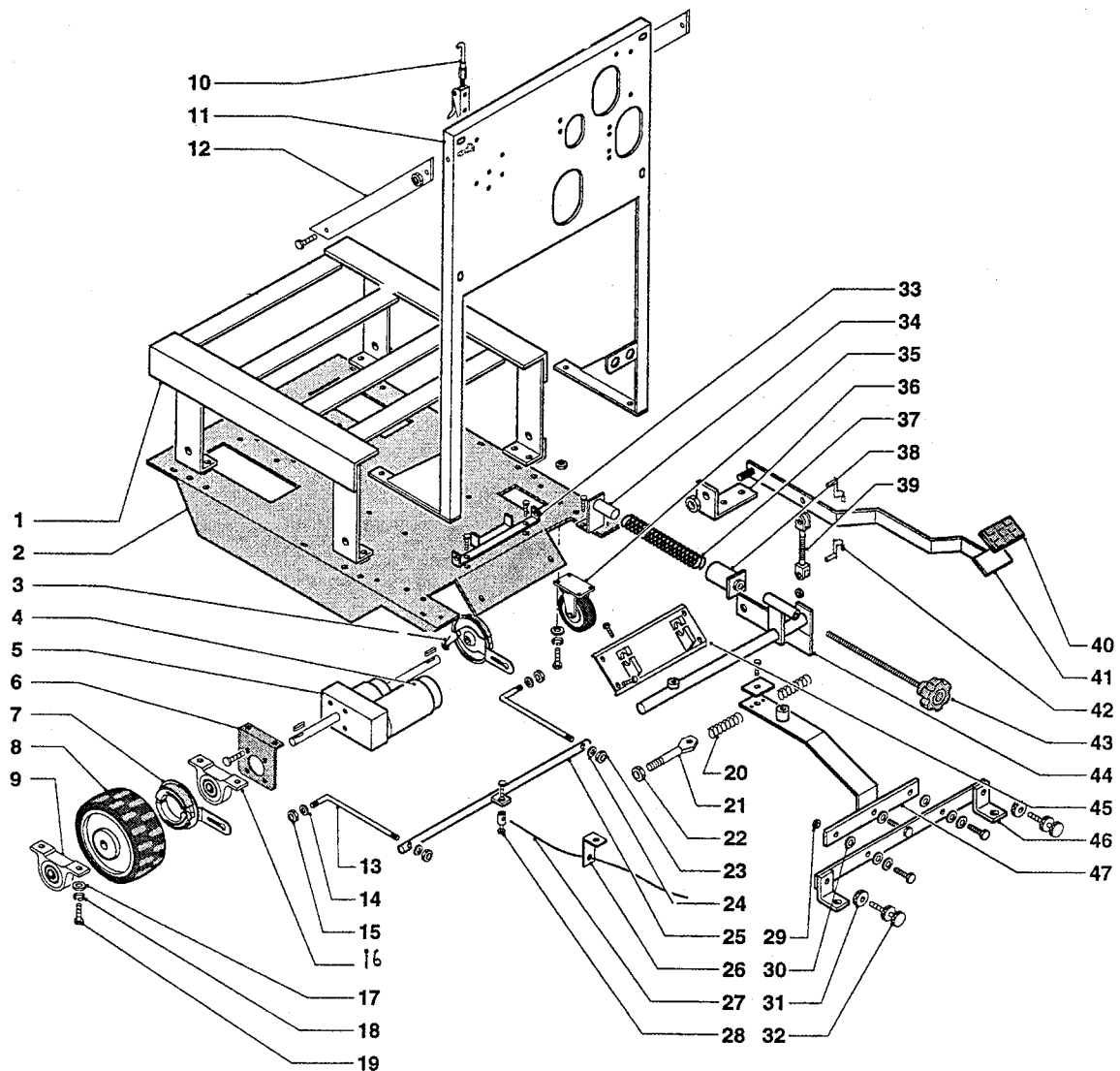

Pos	Part No.	Description	Pos	Part No.	Description
1	860.001	Support	24	860.024	Washer
2	860.002	Frame	25	860.025	Shaft
3	PAS900	Drum Brake	26	860.026	Yoke
4	PAS901	Motor, traction	27	PAS910	Cable, brake
5	PAS902	Differential gear	28	PAS173	Clamp
6	PAS903	Yoke	29	PAS911	Nut
7	PAS904	Drum Brake, left	30	PAS912	Washer, nylon
8	PAS905	Wheel, traction	31	PAS33	Ring Nut
9	PAS906	Bearing and housing	32	PAS34	Regulator
10	PAS132	Hook	33	860.033	Support
11	860.011	Back Frame	34	860.034	Support with Spring
12	860.003	Yoke	35	PAS913	Swivel Castor
13	860.013	Rod	36	700.030	Bracket
14	860.014	Washer	37	PAS914	Spring, squeegee
15	860.015	Nut	38	PAS915	Stop, spring
16	PAS61	Bearing and housing	39	PAS916	Tie Rod
17	PAS188	Washer	40	PAS917	Pedal Cover
18	PAS907	Lockwasher	41	860.041	Pedal
19	PAS190	Screw	42	PAS918	Pin
20	PAS908	Spring	43	860.043	Screw
21	PAS909	Tie Rod	44	860.044	Lever
22	PAS176	Nut	45	860.045	Support
23	860.023	Nut	46	860.046	Support
			47	860.047	Lever

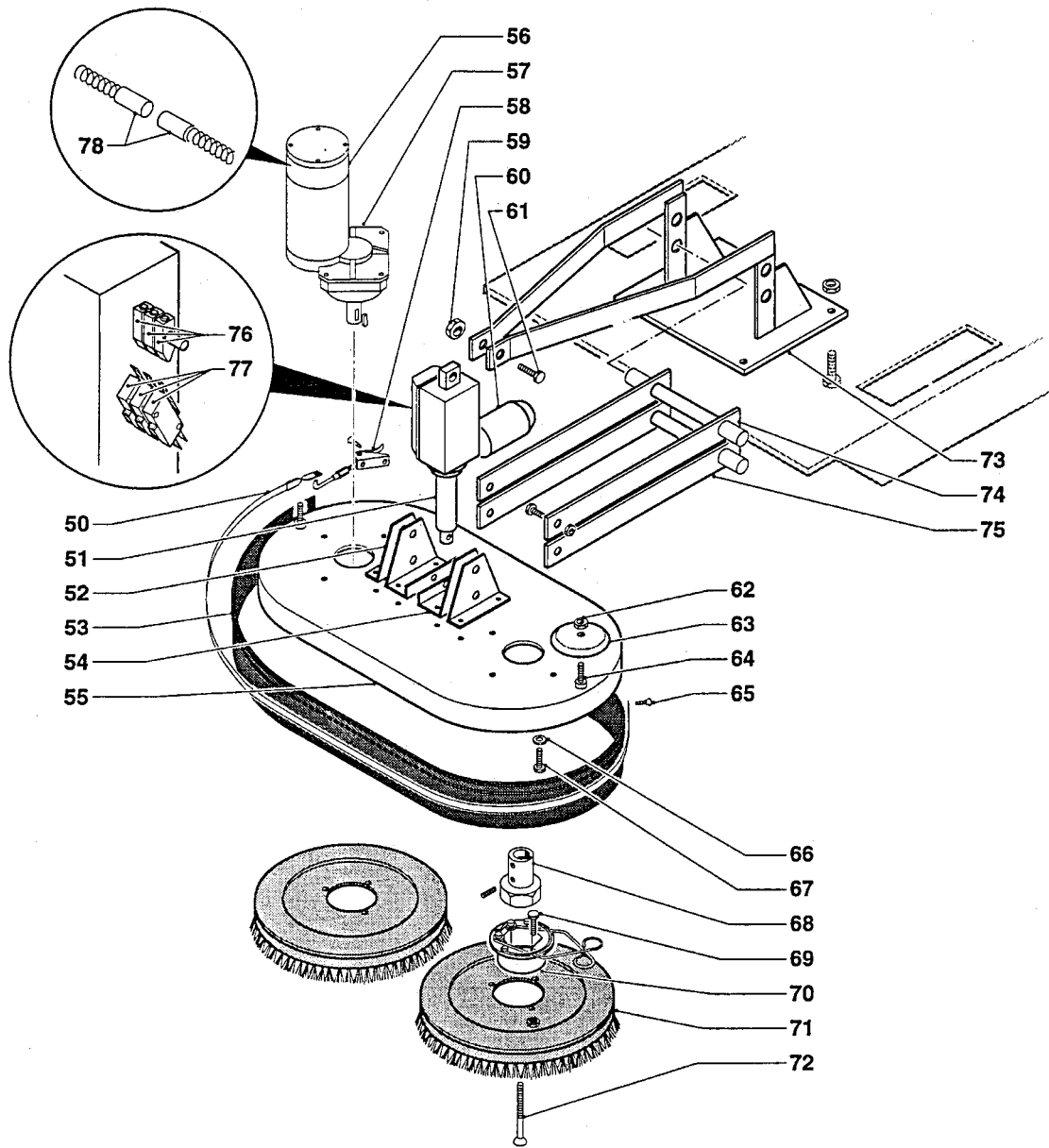

Pos	Part No.	Description
50	PAS919	Strap, bumper
51	PAS920	Pressure Drive
52	860.052	Bracket
53	PAS921	Splash Guard
54	860.054	Plate
55	860.055	Support
56	PAS922	Motor, brush drive
57	PAS956	Gear Unit
58	PAS122	Hook
59	PAS923	Nut, pressure drive
60	PAS957	Motor, pressure
61	PAS958	Screw
62	PAS924	Nut
63	PAS1	Buffer Wheel
64	PAS925	Screw
65	PAS926	Screw
66	PAS146	Washer

Pos	Part No.	Description
67	PAS927	Screw
68	PAS5	Coupling
69	PAS65	Screw
70	PAS6A	Support with Spring
71	PAS962	Poly-Scrub .028 Dia. Scrub Brush Nylon
	PAS963	Nylo-Grit .050 Dia. 80 Grit HD Clean and Strip
	PAS964	Strata-Grit .060 Dia. 46 Grit Concrete Cleaning
	PAS961	Drive Block
	PAS965	Powr-Scuff .018 Dia. 500 Grit Gen Scrub
	PAS966	Powr-Scrub II .022 Grit Deep Scrub
72	PAS111	Coupling Screw
73	860.073	Support
74	860.074	Superior Lever
75	860.075	Inferior Lever
76	860.076	Cam
77	PAS928	Micro Switch
78	PAS929	Carbon Brush

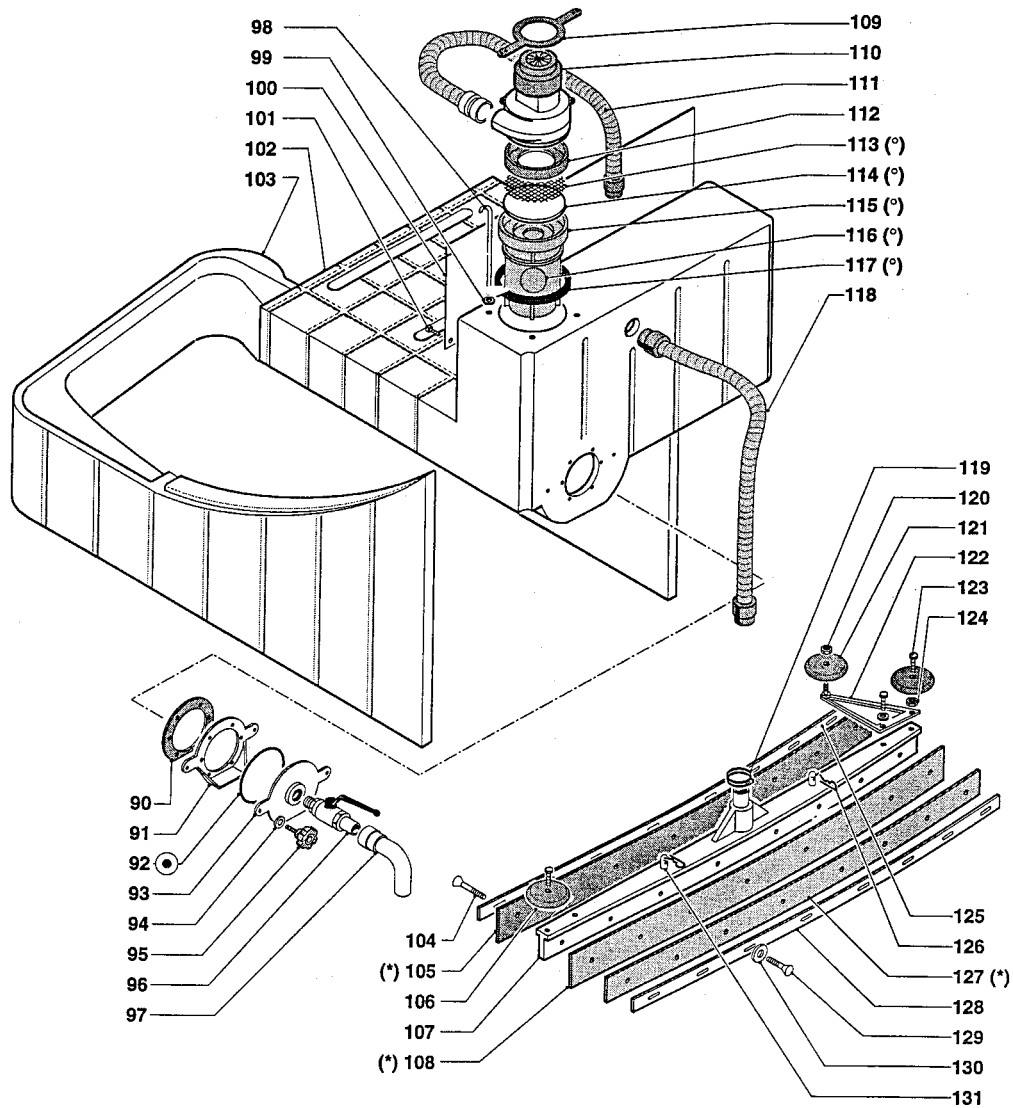

Pos	Part No.	Description	Pos	Part No.	Description
(°)	PAS17	Complete Float Level	109	PAS15	Lock Ring
(*)	PAS930	Kit, Squeegee 3 piece	110	1932A	Vac Motor, 2 stg, 36V
90	PAS70	Gasket	111	PAS37	Flex Hose
91	PAS71	Fixed Flange	112	PAS102	Motor Gasket
92	PAS72	Gasket	113	F909	Filter Screen (includes pos. 114)
93	PAS73	Movable Flange	115	PAS85	Support
94	PAS186	Washer	116	500.094	Float Level
95	PAS174	Knob	117	PAS103	Gasket
96	PAS75	Dump Valve	118	PAS80	Intake Hose
97	PAS187	Elbow, Drain	119	PAS191	Hose Collars
98	PAS150	Tie Rod	120	PAS935	Nut
99	PAS146	Washer	121	PAS1	Bumper Wheel
100	860.100	Screw	122	850.278	Right Vibration Damper
101	PAS147	Screw	123	PAS936	Screw
102	PAS204	Vacuum Tank	124	PAS937	Nut
103	860.103	Housing Collar	125	PAS938	Outer Bar, Squeegee
104	PAS223	Screw	126	PAS959	Spring Clip, Squeegee
105	PAS931	Black Rubber, Squeegee	127	PAS939	Squeegee Stiffener
106	PAS1	Bumper Wheel	128	PAS959	Outer Bar, Rear
107	PAS932	Squeegee Frame	129	PAS223	Screw
108	PAS933	Squeegee Main Blade	130	PAS941	Washer
			131	PAS942	Spring Clip, Squeegee

Pos	Part No.	Description	Pos	Part No.	Description
135	PAS943	Lid	150	500.051	Lever
136	PAS944	Solution Tank	151	430.078	Nut
137	PAS3	Filter	152	700.161	Rod
138	860.138	Hinge	153	PAS84	Support
139	860.138	Hose	154	700.154	Screw
140	PAS82	Hose Converter	155	700.155	Screw
141	PAS945	Hose, Solution	156	PAS948	Lid Hinge
142	PAS83	Quick Connection, Male	157	PAS11	Knob
143	PAS947	Quick Connection, Female	158	700.158	Support
144	PAS946	Hose, Solution	159	430.056	Screw
145	860.154	Hose	160	700.160	Hook, Cord
146	430.091	Hose Clamp	161	PAS155	Rod
147	400.161	Nut	162	PAS949	Control Panel
148	PAS12	Solution Valve	163	PAS153	Screw
149	PAS146	Nut	164	860.164	Housing, Rear