

Predator Automatic Scrubber 20

OPERATORS MANUAL AND PARTS LIST

Model PAS20



WARNING: OPERATOR MUST READ AND UNDERSTAND THIS MANUAL COMPLETELY BEFORE OPERATING THIS EQUIPMENT.

TECHNICAL CHARACTERISTICS
POWR-FLITE® PREDATOR™ 20 AUTO SCRUBBER MODEL PAS20

Technical Specifications	U.S. Standard	Metric
Area per hour	22,000 sq. feet.....	2043 sq. meters
Solution Tank	10 gallons.....	38 liters
Recovery Tank	10 gallons.....	38 liters
Cleaning Width (brush)	20 inches.....	500 mm
Squeegee Width	29½ inches.....	750 mm
Brush Pressure	90 lbs.	41 kg.
Brush Speed	225 RPM	
Brushes	(1) 20 inches	(1) 500 mm
Brush Motor (power rating)	24 volts/500 watts	
Brush Motor (power rating)	¾ HP	
Vacuum Motor (power rating)	24 volts/450 watts (Bypass)	
Driver Motor (power rating)	24 volts/150 watts (Electronically Controlled)	
Supply Voltage (battery)	24 volts	
Continuous Operating Run Time	3-4½ hrs. battery chg.	
Batteries	12 volt, 120 amp min.-190 amp max., 2 required (deep cycle group 27)	
Dimensions - Scrubber	44"L x 20"W x 38"H.....	1100mmL x 505mmW x 950mmH
Weight w/o batteries	220 lbs.	100 kg.
Battery storage area	13¾"L x 13¾"W x 9"H.....	344mmL x 344W x 225mmH

IMPORTANT SAFETY INSTRUCTIONS

All operators must read, understand and practice the following safety instructions. They will be repeated occasionally throughout this manual, and additional cautions may be added for specific cases.

- **CAUTION:** Operators must read and understand this manual completely before operating this equipment.
- **CAUTION:** Make sure key switch is in the “OFF” position before installing pad.
- **CAUTION:** Loose objects on the floor can become dangerous projectiles if struck by the high-speed pad. Remove them before operating this machine.
- **CAUTION:** Keep hands and feet away from revolving pad.
- **CAUTION:** Keep machine moving to prevent damage to finish or floor.
- **CAUTION:** Make sure key switch is turned “OFF” and battery connector is unplugged from machine before performing any maintenance procedures.
- **CAUTION:** Maintenance and repairs must be performed by authorized personnel.
- **CAUTION:** Battery acid can cause burns. When working on or around batteries, wear protective clothing and safety glasses. Remove metal jewelry. Do not lay tools or metal objects on top of batteries.
- **CAUTION:** Do not operate this equipment in bare feet or with open-toed shoes or sandals.
- **CAUTION:** Charging batteries generate explosive gases. ***NO SMOKING OR OPEN FLAMES OR SPARKS.*** Make sure the charger has turned off before disconnecting it from the batteries. Charge batteries in a well-ventilated area with the tanks in the raised and locked position.
- **CAUTION::** Store or park this machine on a level surface only. Remove key from switch if machine is left unattended.
- **CAUTION::** Do not operate machine or charger in areas where flammable liquids or gases are present. Do not use or pick up flammable chemicals or liquids with this machine.
- **CAUTION:** Make sure all caution, warning and instructional decals are in place and legible. Replace damaged or missing labels.
- **CAUTION:** These machines are designed for level floor operations only. ***DO NOT OPERATE*** on ramps or inclines unless adequate personnel are available for assistance.
- **CAUTION:** Do not expose electrical components to water or other liquids. To clean machine wipe down with a damp cloth.

POWR-FLITE PREDATOR AUTOMATIC SCRUBBER 20

This manual refers to a battery powered automatic floor scrubber. Designed to be simple, easy to operate and safe, with maneuverability and automatic variable electronic drive. Routine maintenance has been simplified and reduced to the minimum to keep equipment on the job.

THE BASIC DESCRIPTION OF THE MACHINE CAN BE SUMMED UP BY THE FOLLOWING FEATURES:

1. Sealed ball-bearing wheels - maintenance free with threaded rubber cast iron wheels.
2. Independent drive system, totally enclosed motor, poly V transmission belt, dual wheel drive for superior traction.
3. State of the art, soft start offers full range and variable drive system powered by fully lubricated sealed drive system.
4. Unprecedented quality & workmanship, simplified control panel.
5. From safety & theft-proof position, control panel equipped with key for "on/off" prevents unauthorized operation.
6. Hospital quiet, reduced noise level.
7. Bypass vacuum motor with tangential discharge.
8. High-speed brush drive with 90 lbs. of contouring pad pressure prevents streaking and produces high productivity.
9. Solution control conveniently located with ease of operation and dispensing control...user friendly...
10. Increased working capacity and productivity offered by higher brush drive speed, increased full contouring pad pressure and operation fatigue eliminating drive system.
11. 15% fewer working parts and components for trouble free operating and servicing machine.
12. 8 year warranty on housing and tanks
5 year warranty on frame
1 year warranty on motor
13. Rotationally molded design for housing, skirt and tank provide lighter weight, chemical resistance and styling features.
14. Design prevents solution contamination with serviceable access to the solution and recovery tanks, vacuum motor and drive motor
15. Nylon squeegee body with reversible rubber squeegees.
16. Easy "Safe" access to the drive brush for pad or brush removal without requiring tilting of the unit to rear.
17. Squeegee design provides smooth follow operation when cleaning along walls and making runs.
18. Formed one piece zinc-plated frame.
19. Aluminum brush housing with baked enamel finish.
20. Vinyl splash skirt will not corrode.
21. Handle mounted safety brake lever.

WARNING:

DO NOT OPERATE MACHINE OR CHARGER IN AREAS WHERE FLAMMABLE LIQUIDS OR GASES ARE PRESENT.

DO NOT USE OR PICK UP FLAMMABLE CHEMICALS OR LIQUIDS WITH THIS MACHINE.

The objective of this manual is to ensure that the machine is operated correctly and performs the service which we offer to our customers. Therefore, we advise **you to follow the instructions it contains scrupulously** since the manufacturer accepts no responsibility for damage to persons, or things, or damage to the machine if the machine is not operated the way described in this manual or if the maintenance and safety instructions are not fully complied with.

The indications provided in this manual do not replace the safety instructions and technical data for installation and operation directly applied on the product, nor do they replace the safety standards current in the country of installation and the rules dictated by normal common sense.

The operator or maintenance worker must advise a person in authority of any faults or deterioration which could affect the original safety of the machine.

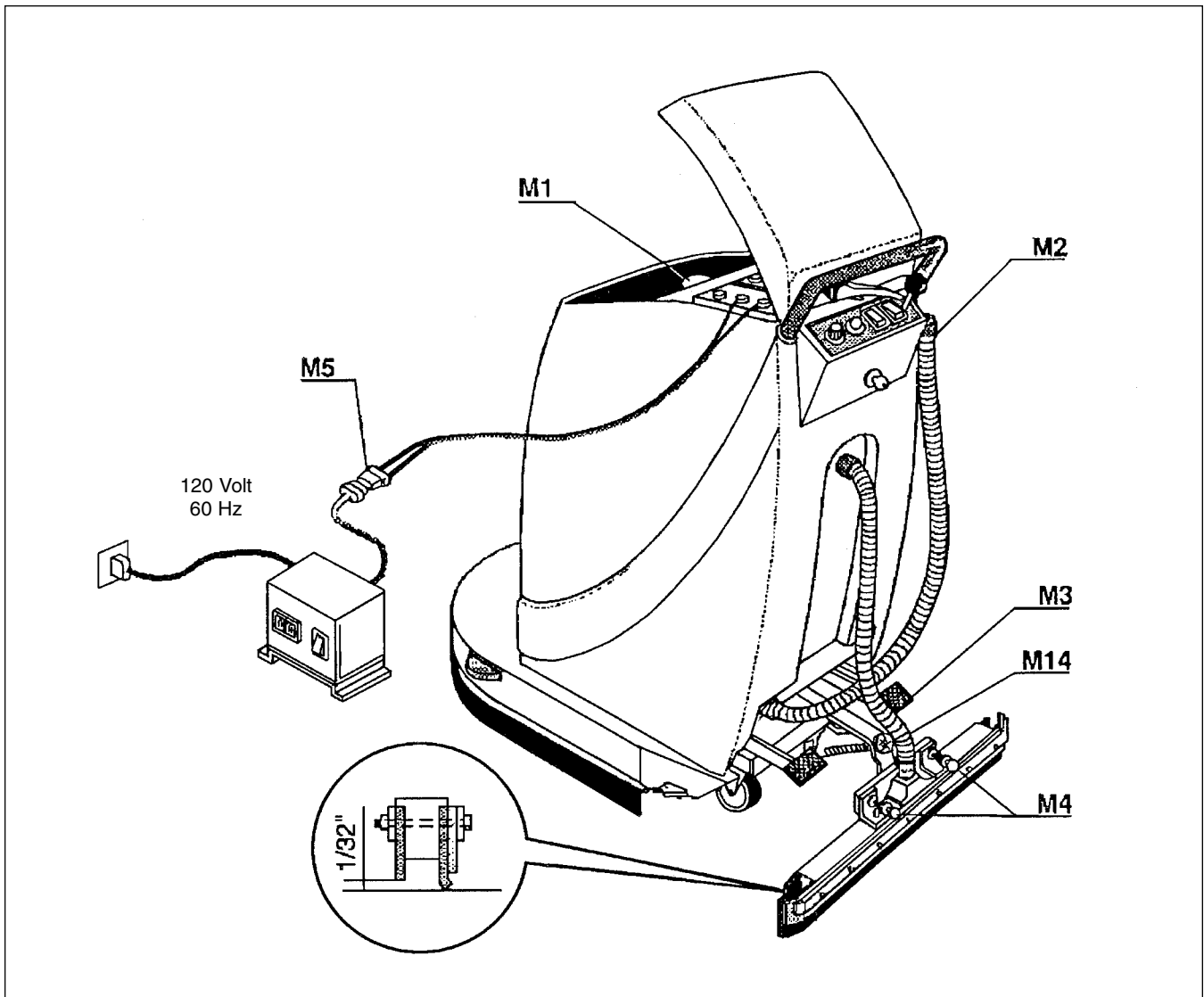

Solution Tank: The solution tank is located under the lid, at the front of the machine, with the filling-funnel **M1** in an accessible position for easy re-filling.

Note: Always empty the dirty water collection tank, as described in the next paragraph, before refilling the tank with the diluted detergent solution. The solution tank has a maximum capacity of 10 gallons (38 liters). Always use the products and the dilution quantities recommended by the seller. Never use foamy detergents. Use defoamer if excess foam develops.

Water collection tank: The dirty water collection tank should be emptied, preferably each time after use, so that the dirt does not settle there. To do this, remove the plug of the drain hose **M2**, which is kept in position by a simple spring clip, and empty dirty water into the proper drain conforming to local regulations.

Squeegee: The squeegee has the final task of completing the drying of the floor and it is very important for it to be in the correct position. Lower the squeegee to the working position by pressing pedal **M3**. Adjust the position of the squeegee by means of the knobs **M4** so that the black rubber bar is about $\frac{1}{32}$ " (the thickness of a business card) from the floor. The squeegee behind this is in para rubber and must press on the

floor with a certain amount of force. *After the first few hours the squeegee adjusts itself to the correct angle and drying becomes even better.* Squeegee pressure is adjusted by knob **M14**.

Battery installation and charging: The batteries are supplied separately and must be inserted in the special compartment provided under the lid. Apply a layer of vaseline to the terminals and connect in series as shown on page 11. Make sure that the terminals are correctly tightened. The battery charger must be installed in the place set aside for charging the machine. The charger is provided with a cable for connection to the mains, normally **120v/60HZ**. Check that the voltage corresponds to the voltage indicated on the battery charger. To charge the batteries, connect the connector of the machine batteries **M5** to the connector of the battery charger. The battery charger will automatically regulate the voltage to the batteries and will switch itself off when the batteries have been fully charged.

CAUTION: **A)** Make sure key switch is turned "OFF" and battery connector is unplugged from machine before performing any maintenance procedures. **B)** Battery acid can cause burns. When working on or around batteries, wear protective clothing and safety glasses. Remove metal jewelry. Do not lay tools or metal objects on top of batteries. **C)** Charging batteries generate explosive gases.

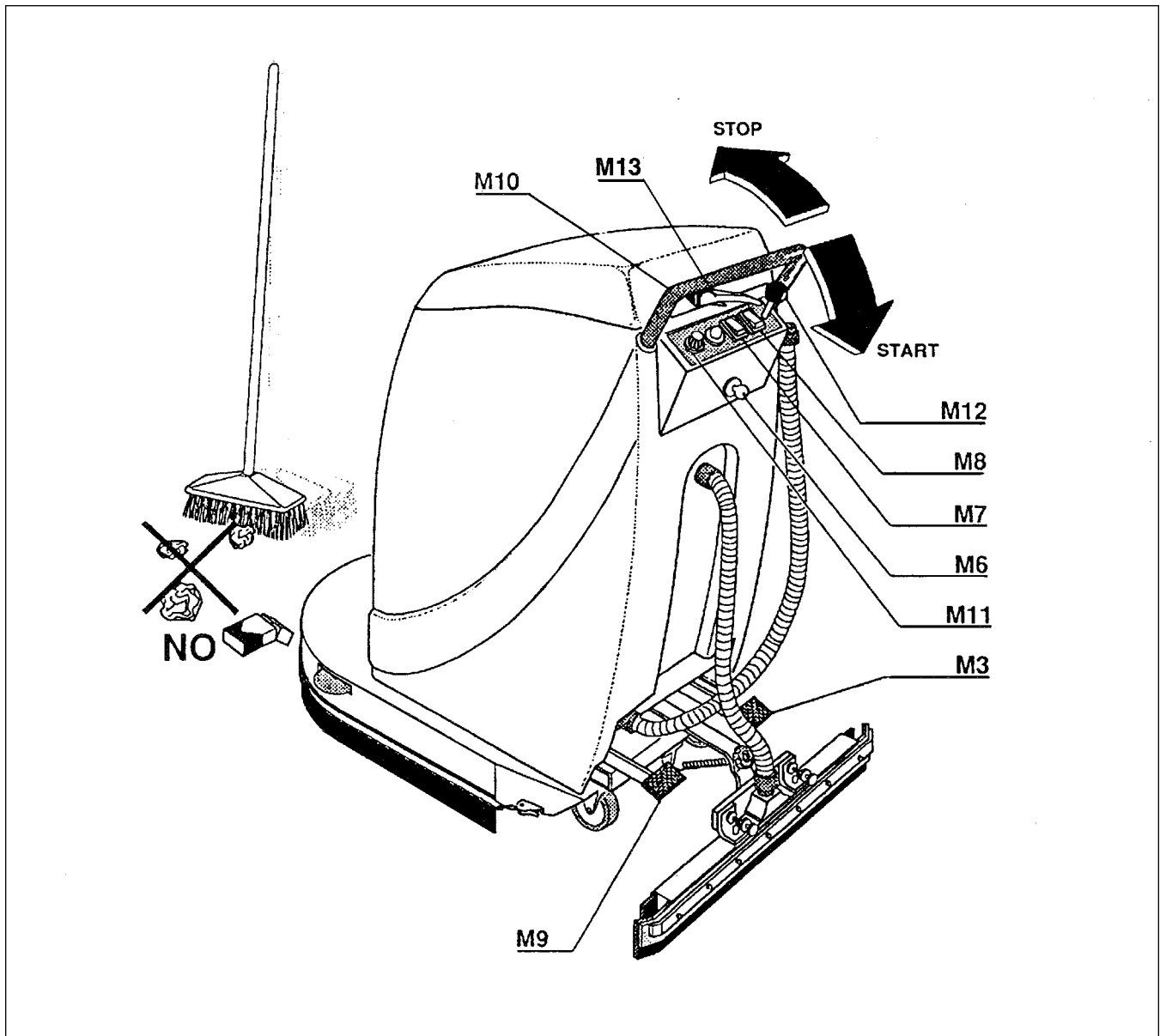

The area to be scrubbed: Debris and grit must be swept up before starting the scrubbing operation to avoid vacuum line blockage and to permit the detergent to perform efficiently.

Prior to startup and operation: *Caution:* A) Loose objects on the floor can become dangerous projectiles if struck by the high speed pad. Remove them before operating machine. B) Keep machine moving to prevent damage to finish or floor. C) These machines are designed for level floor operations only. **DO NOT OPERATE ON RAMPS OR INCLINES** unless adequate personnel are available for assistance.

Starting up and operation: Disconnect the batteries from the battery charger and connect to the machine.

Then:

- Turn master switch **M6** to position 1 and press switches **M7** and **M8**.
 - Lower the brush by pressing pedal **M9**.
 - Lower the squeegee by pressing pedal **M3**.
 - Set the detergent solution supply to minimum by adjusting knob **M12**.
 - Release brake by depressing small lever on **M13**.
 - Press down the handle **M10** to drive forward.
- When the handle is released the machine stops.

- Adjust the speed of advance by adjusting knob **M11**.
- Finally, adjust the correct supply of the detergent as a function of the amount of dirt and speed of advance by means of lever **M12**; this is a matter of experience. At this point the machine is ready to carry out the operations of scrubbing and drying at the same time.

Particularly dirty floors: Certain floors or areas may require special attention and, in some cases, cleaning twice. Go over the floor quickly the first time, with the squeegee raised and the brush in the working position. In this way, the detergent solution is left on the floor for a longer time and can dissolve the heavy dirt. The second time, go over the floor more slowly with both the brush and the squeegee lowered. Always apply and brush stripping solution without squeegee and vacuum then return to area after a minimum of 5 minutes and remove the suspended dirt, finish and solution. Stripping solutions are most effective when applied with a mop or specialized applicator and allowed to work on the finish for at least 5 minutes. This will also prevent contamination of the unit's solution tank, and eliminate rinsing & neutralizing the tank before rinsing floor.

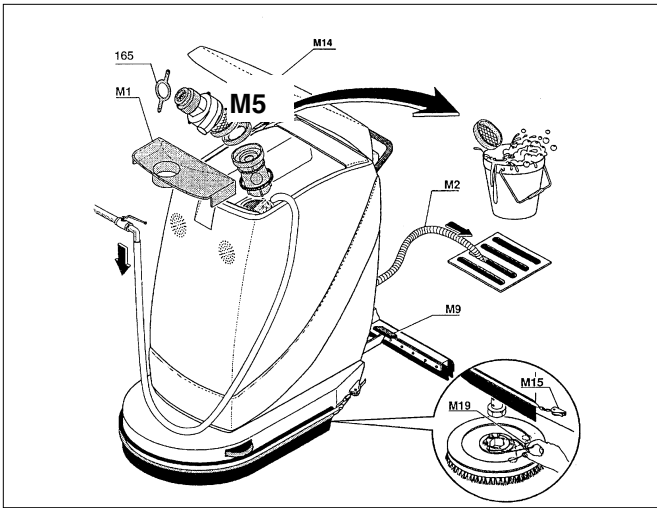

Squeegee: Every week, check the blades of the squeegee and wash them carefully. Then adjust them in the correct working position (*see above*). If drying is not perfect even after the unit has been cleaned, replace any blades which are excessively worn. Tighten fasteners from the center to the outside only. If the squeegee does not pick up enough water or streaks, lift and wipe off the blades.

The pad driver or brush must be in good working condition because it is the component which removes the dirt.

To remove the drive block, pad or brush:

- Fold the vinyl bumper over the left side of the brush housing.
- Depress the brush pedal (M9) with your right hand hold the brush position to allow free spinning by hand of the driver or brush until the scissors style spring lock can be squeezed with your left hand.
- Depress the brush pedal (M9) completely down clearing the brush or drive block and slide brush or driver out from under the housing.

To replace the drive block, pad or brush:

- Hold the brush pedal (M9) down while centering the brush or driver under coupling. While squeezing the spring lock together lower the coupling into the driver or brush center by allowing the brush pedal to raise. Release the scissors spring lock

The machine is supplied with a pad driver. Brushes in carbide grit, poly and steel are available on request, together with floor pads recommended for use with the pad driver. **Black** for stripping, **green** for deep scrub, **blue** for cleansing and red for light scrub.

Water collection tank: This tank should be cleaned every week. Lift the lid and remove the funnel M1 of the solution tank. Remove the strap M5 and lift the vacuum motor out of its seat. Remove filter M14 and float cage from motor and thoroughly clean with water and wash out the dirt deposited in the tank with a jet of water, allowing it to drain out through hose M2. If necessary, replace filter. Place float cage back with open side facing front of machine.

Batteries: Check the level of the electrolyte liquid by carefully removing plugs from top of battery and top off with distilled water, when the level drops below the plates of the battery. Keep the batteries clean and dry with antistatic cloths. When charging the batteries, remove the plugs of the batteries and lift the top flap of the machine to allow the gas which is generated to escape. **This gas can cause explosions in closed environments** and, therefore, it is advisable to carry out battery charging in well-ventilated environments.

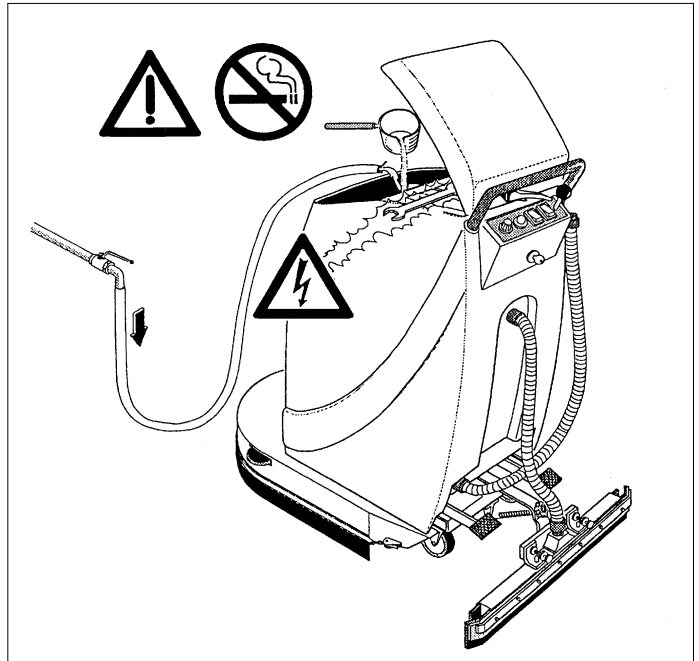

WARNING! Do not operate machine or charger in areas where flammable liquids or gases are present. Do not use or pick up flammable chemicals or liquids with this machine.

CAUTION! Make sure all caution, warning and instructional decals are in place and legible. Replace damaged or missing labels.

This auto scrubber has been designed to the strictest safety standards but the user must still use the machine with care and caution.

Here are a few rules which must be respected:

- Never leave the machine unattended, particularly when there are children around
- Always switch off the machine when filling the solution tank
- Never attempt to make emergency repairs or use non-original spare parts.
- Check the wear and deterioration of the materials at intervals and ask the sales representative for assistance.
- Do not smoke or expose open flames or sparks in the vicinity of the batteries (*portable grinders, welders, etc.*)
- Do not take current from the batteries using ad hoc clips or other forms of temporary connections.
- Do not rest metal tools or instruments on the batteries because the electrolyte liquid is corrosive.

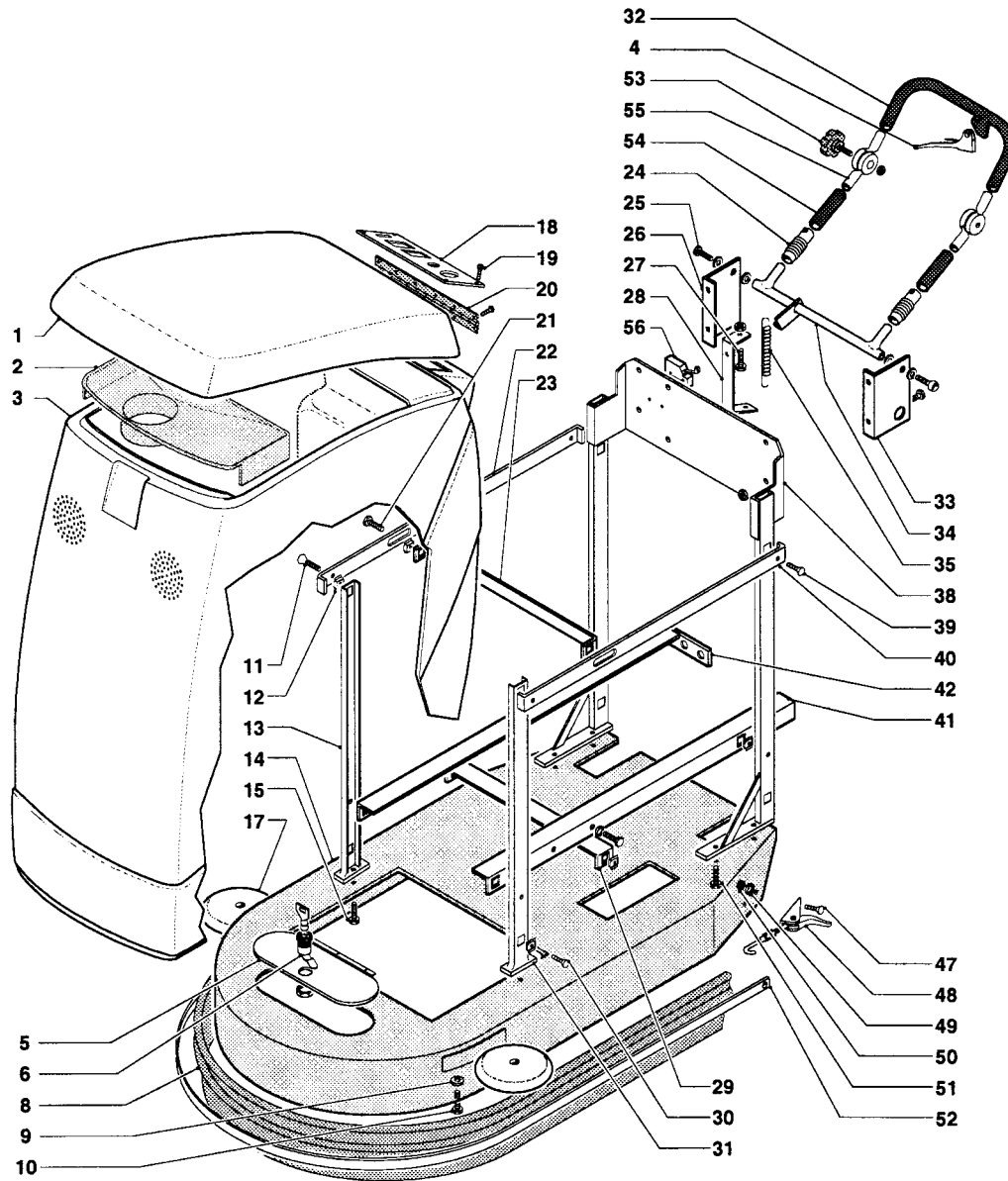

Pos	Part No.	Description	Pos	Part No.	Description	Pos	Part No.	Description
1	PAS275	Lid	17	PAS1	Wheel, Bumper	34	PAS158	Handle Lever
2	PAS104	Funnel	18	PAS152	Control Panel	35	PAS18	Spring
3	PAS 185	Housing	19	PAS153	Screw	36	PAS115	Screw
	*PAS 104B	Funnel (Serial #2674 & higher)	20	PAS109	Hinge	38	501.038	Panel
	*501.003.1	Housing (Serial #2674 & higher)	21	PAS147	Screw	39	PAS147	Screw
4	PAS166	Brake Lever	22	501.022	Crosspiece	40	501.022	Crosspiece
8	PAS2	Splash Guard	23	501.023	Bracket	41	501.041	Bracket
9	PAS 157	Washer	24	PAS335	Bellows	42	501.042	Bracket
10	430.016	Screw	25	PAS167	Screw	47	501.047	Screw
11	501.011	Screw	26	501.026	Bracket	48	PAS 122	Hook
12	430.063	Nut	27	PAS114	Screw	49	501.049	Washer
13	501.013	Bracket	28	PAS183	Support	50	501.050	Nut
14	PAS800	Housing, Brush	29	501.029	Bracket	51	PAS167	Screw
15	PAS167	Screw	30	PAS147	Screw	52	PAS100	Strap
17	PAS1	Wheel, Bumper	31	501.013	Bracket			
			32	PAS158	Upper Handle			
			33	501.033	Bracket			

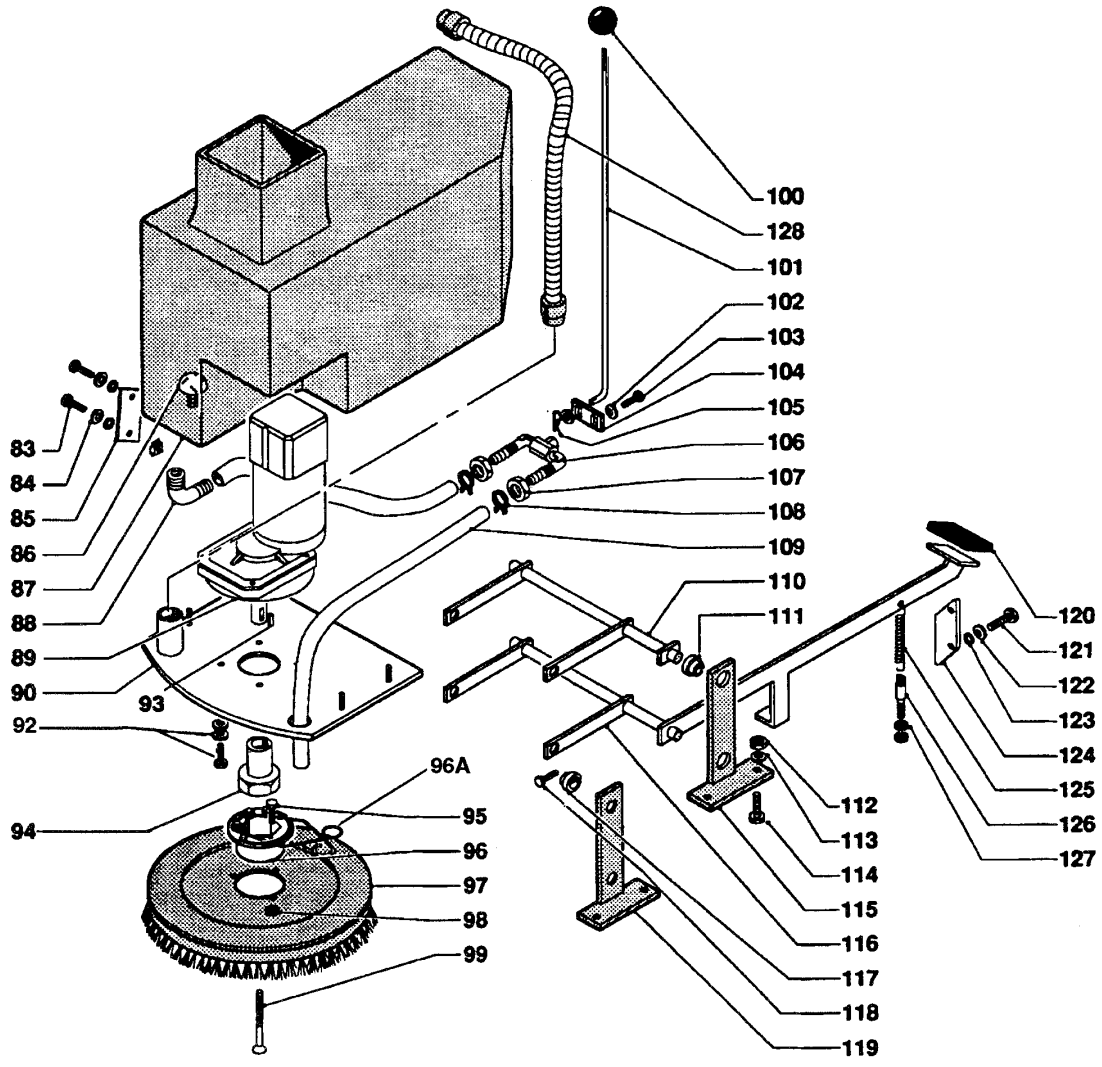

Pos	Part No.	Description	Pos	Part No.	Description	Pos	Part No.	Description
83	PAS147	Screw	97	PAS8	Brush, poly	112	430.117	Nut
84	PAS146	Washer	97	PAS132	Strata Grit brush	113	PAS188	Washer
85	501.086	Plate	97	PAS95	Scrub Grit II brush	114	PAS167	Screw
86	PAS 3	Screen	97	PAS10	Pad driver	115	430.119	Support
87	PAS401	Solution Tank	97	PAS135	Powr-Scuff brush	116	PAS203	Lever, lower
88	501.088	Elbow	98	430.078	Nut	117	500.155	Bushing
89	PAS 4	Geared motor	99	PAS111	Bolt	118	501.118	Screw
90	PAS241	Plate	99	PAS11	Knob	119	430.094	Support
92	PAS111	Screw & washer coupling	100	PAS11	Knob	120	PAS14	Cushion
93	PAS101	Dowel	101	PAS151	Rod	121	430.107	Screw
94	PAS5	Coupling half	102	PAS270	Nut	122	PAS146	Washer
95	PAS65	Screw	103	PAS271	Screw	123	PAS208	Washer
96	PAS6	Support w/long spring	104	PAS269	Valve Lever	124	PAS259	Plate
96A	PAS7	Long Spring for support	105	PAS268	Split Pin	125	PAS230	Spring
96B	PAS6	Support Only	106	PAS12	Solution valve	126	PAS63	Pin
			107	PAS262	Nut	127	PAS176	Nut
			108	PX42	Hose Clamp	128	PAS37	Dump hose
			109	PAS288	Hose			
			110	430.092	Lever, upper			
			111	500.155	Bushing			

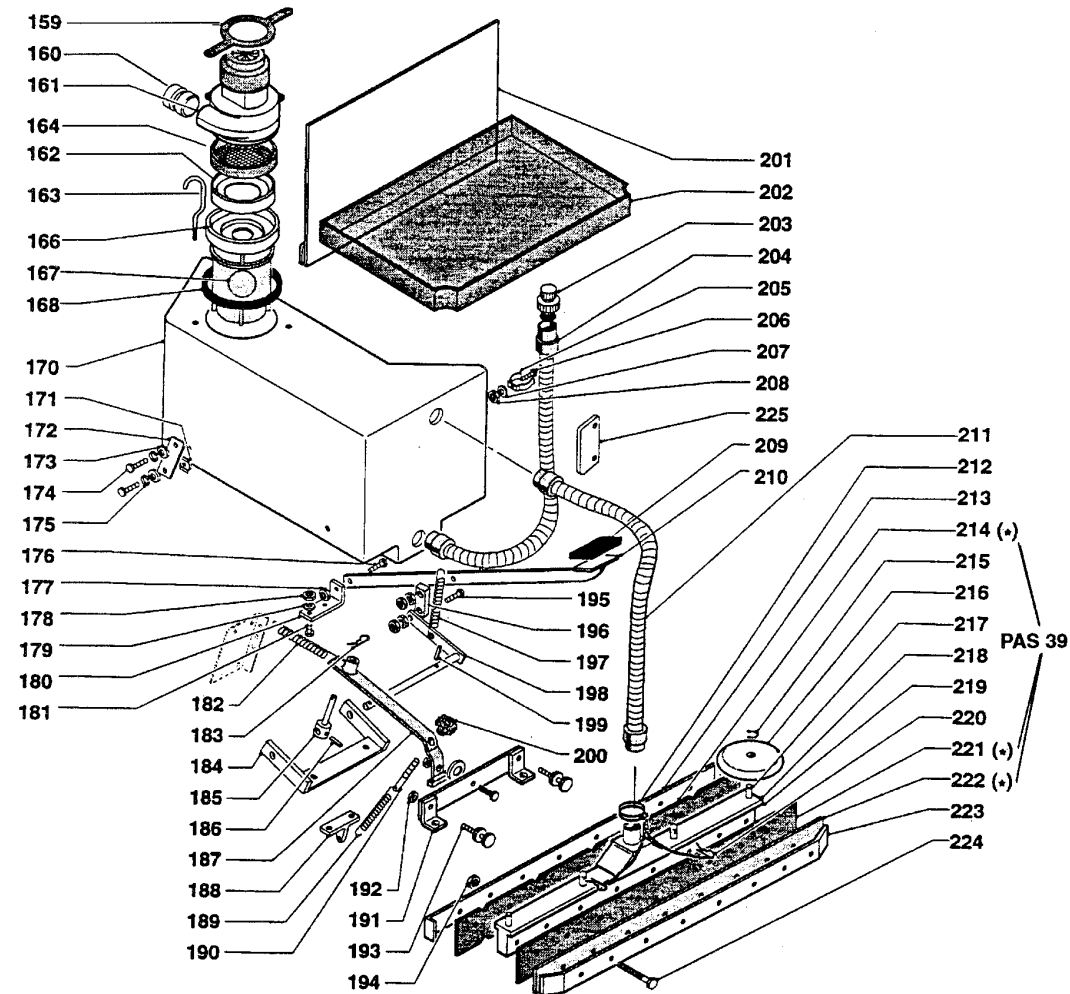

Pos	Part No.	Description	Pos	Part No.	Description	Pos	Part No.	Description
159	PAS15	Strap	182	PAS18	Spring	204	PAS37	Drain hose
160	PAS330	Sleeve	183	PAS266	Split pin	205	PAS38	Spring
161	1924	Vac motor	184	501.184	Bracket	206	430.194	Screw
162	PAS102	Gasket	185	PAS19	Pin	207	PAS146	Washer
163	PAS150	Tie rod	186	500.157	Washer	208	430.192	Nut
164	F909	Screen/Filter	187	PAS184	Lever	209	PAS14	Cushion
166	PAS17	Float support	188	PAS403	Bracket	210	501.210	Squeegee lever
167	PAS210	Float	189	PAS31	Spring	211	PAS37	Intake Hose
168	PAS103	Seal	190	PAS32	Pin	212	PAS191	Clamp, hose
169	PAS149	Nut	191	PAS404	Support	213	PAS192	Outer bar
170	PAS400	Collection tank	192	PAS33	Ring nut	214	PAS142	Black rubber
171	430.063	Nut	193	PAS34	Adj., screw	215	PAS81	Clip
172	501.086	Plate	194	PAS149	Nut	216	PAS33	Wheel, bumper
173	PAS146	Washer	195	PAS197	Screw	217	PAS193	Pin
174	PAS147	Screw	196	PAS265	Plate	218	PAS40	Squeegee band group
175	PAS208	Washer	197	PAS 230	Spring	219	PAS194	Squeegee body
176	501.176	Screw	198	501.198	Lever	220	PAS41	Split pin
177	501.177	Nut	199	PAS280	Roll Pin	221	PAS116	Squeegee blade
178	PAS189	Nut	200	PAS35	Knob	222	PAS112	Squeegee blade
179	PAS188	Washer	201	PAS105	Plate	223	PAS196	Outer, bar
180	501.180	Bracket	202	PAS381	Tray	224	PAS197	Screw
181	PAS167	Screw	203	PAS36	Expansion plug			

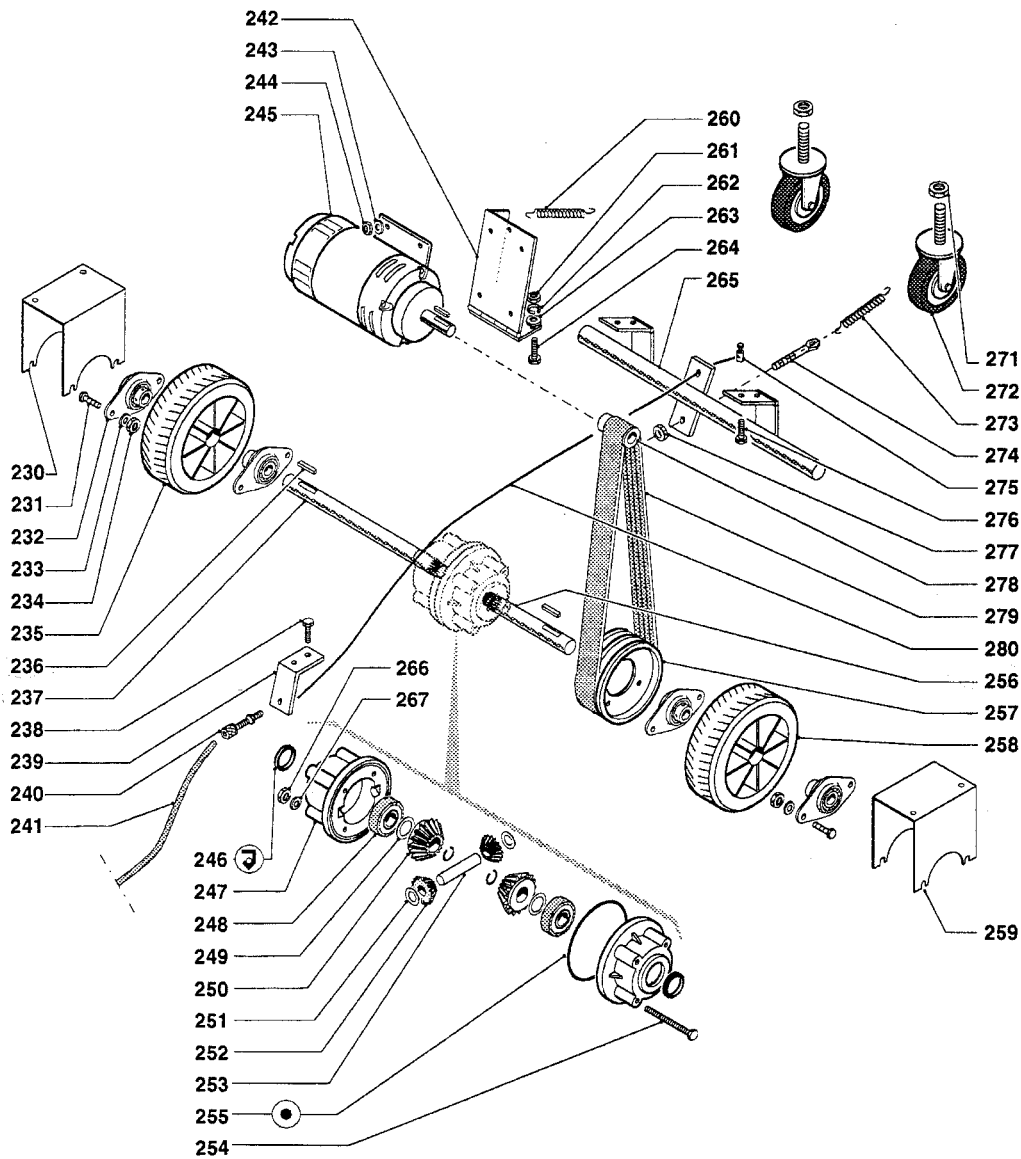

Pos	Part No.	Description	Pos	Part No.	Description	Pos	Part No.	Description
230	501.23	Support	249	PAS286	Ring	271	PAS207	Nut
231	PAS190	Screw	250	PAS287	Planet gear	272	PAS51A	Swivel castor
232	PAS42	Support	251	PAS289	Ring	273	PAS172	Spring
233	PAS188	Washer	252	501.252	Planetary	274	PAS63	Pin
234	430.231	Self locking nult	253	PAS291	Pin	275	PAS173	Clamp
235	PAS189	Wheel	254	PAS292	Screw	276	PAS167	Screw
236	501.236	Tang	255	501.255	Seal	277	PAS176	Nut
237	PAS293	Shaft	256	PAS282	Shaft	278	PAS907	Washer
238	PAS167	Screw	257	501.257	Pulley	279	PAS48	Belt
239	PAS169	Square	258	PAS44A	Wheel	280	PAS168	Cable
240	PAS170	Regulator	259	201.23	Support			
241	PAS171	Sheathing	260	PAS18	Spring			
242	PAS233	Plate	261	PAS176	Nut			
243	PAS146	Washer	262	PAS907	Lock washer			
244	PAS149	Nut	263	PAS188	Washer			
245	PAS47	Motor	264	PAS167	Screw			
246	PAS283	Seal ring	265	PAS180	Brake shaft			
247	PAS284	Bell	266	PAS149	Nut			
248	PAS285	Bearing	267	PAS146	Washer			

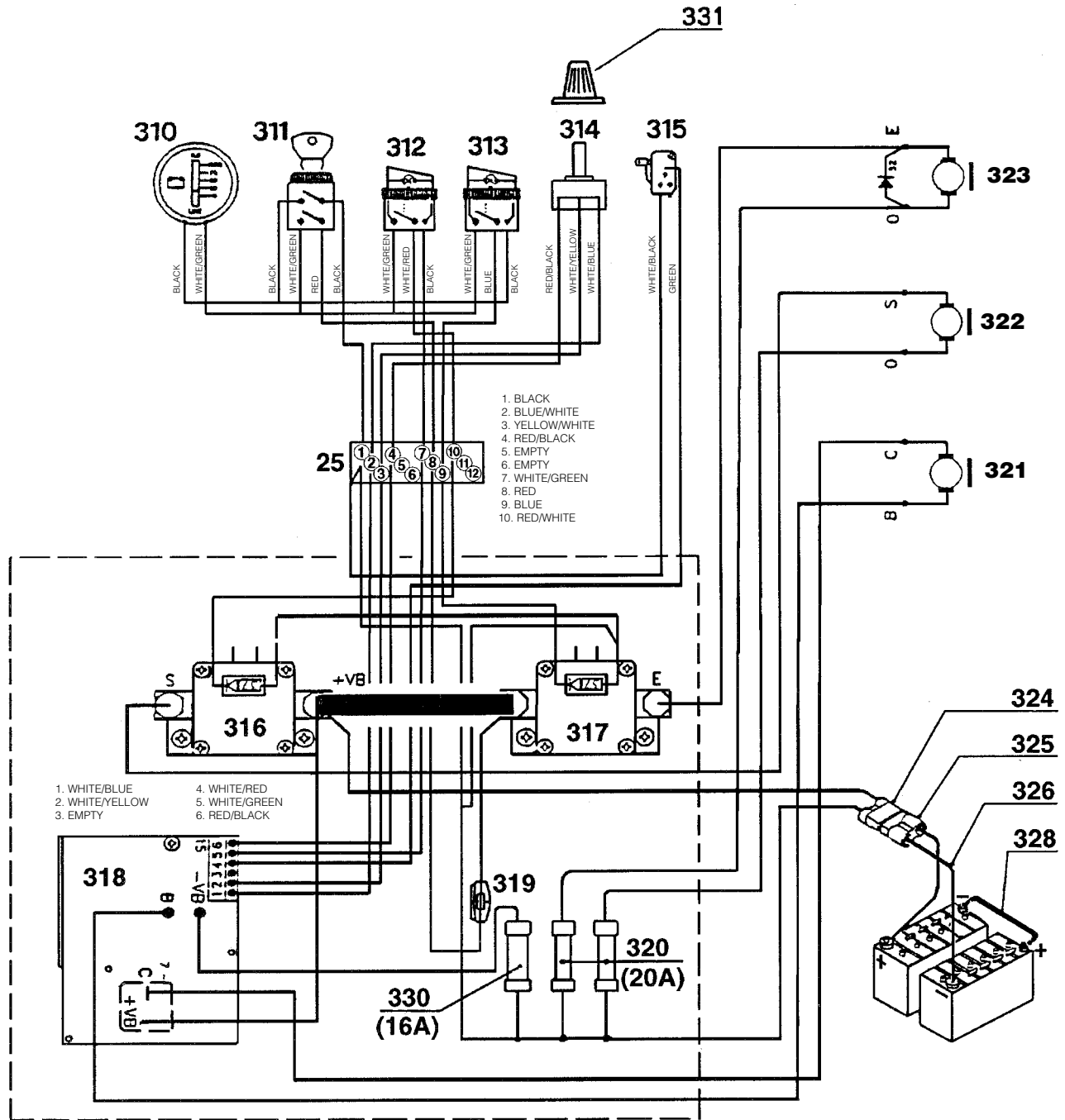

Pos	Part No.	Description	Pos	Part No.	Description
310	PAS 52	Battery gauge	320	PAS 118	20 amp fuse, main
311	PAS 53	Master switch	321	PAS 47	Drive motor
312	PAS 54	Brush switch	322	PAS 4	Brush motor
313	PAS 54	Vac Switch	323	1924	Suction motor
314	PAS 55	Speed potentiometer	324	PAS 59	Connector
315	PAS 56	Micro switch	325	PAS 59	Connector
316	PAS 57	Brush solenoid	326	PAS 140	Cable w/ connector
317	PAS 57	Vac solenoid	328	PAS 141	Jumper cable
318	PAS 58NS	Electronic plate	330	PAS 117	16 amp fuse
319	PAS 119	Auxiliary fuse	331	PAS 88	Knob

Alarms on Electronic Card

1. The motor is not in stand still position at starting.
2. Battery voltage is too low.
3. Battery voltage is too high.
4. The potentiometer is not in zero position at starting.
5. The potentiometer is interrupted.
6. Overheating
7. Braking has over come max allowed time.
8. Eprom wrong programming
9. Power error.

Power-Flite[®]
COMMERCIAL FLOOR CARE EQUIPMENT

A Tacony Company
3101 Wichita Court • Ft. Worth, TX 76140-1755
1-800-880-2913