

Powr-Flite
COMMERCIAL FLOOR CARE EQUIPMENT

BlackMax Floor Machine

Models: B171, B171HD, B172, B201, B201HD, B202



IMPORTANT SAFETY INSTRUCTIONS

WARNING: READ ALL SAFETY INSTRUCTIONS BEFORE USE!

GENERAL WARNINGS

To reduce risk of fire, electric shock, or injury:

This machinery should only be used by trained personnel.

Do not leave floor machine unattended when plugged in. Unplug the electrical cord when not in use and before servicing.

Do not allow to be used as a toy. Close attention is necessary when used by or near children.

Use only as described in this manual. The use of accessories which have not been approved or supplied by the manufacturer may be dangerous.

Do not use with damaged cord or plug. If floor machine is not working as it should, has been dropped, damaged, left outdoors, or dropped into water, return it to service center before using.

Do not pull or carry by cord, use cord as a handle, close a door on cord, or pull a cord around sharp edges or corners. Do not run floor machine over cord.

Keep cord away from heated surfaces.

Do not use extension cords or outlets with inadequate current carrying capacity.

Release handle before unplugging.

Do not handle plug or floor machine with wet hands.

Do not put any objects into openings.

Do not use with top of the unit covered. Keep free of dust, lint, hair, and anything that may reduce airflow around the top of the motor.

Keep loose clothing, hands feet and any other object away from the bottom of the machine during use.

Do not use this machine around flammable materials or liquids.

Maintenance and repair must be done by an authorized repair center.

Store your cleaner indoors in a cool dry area.

Do not unplug by pulling on cord. To unplug, grasp the plug, NOT THE CORD.

THIS MODEL IS GROUNDED, CONNECT TO A PROPERLY GROUNDED OUTLET ONLY.

GROUNING INSTRUCTIONS

This appliance must be grounded. If it should malfunction or break down, grounding provides a path of least resistance for electric current to reduce the risk of electric shock. This appliance is equipped with a cord having an equipment-grounding conductor and grounding plug. The plug must be plugged into an appropriate outlet that is properly installed and grounded in accordance with all local codes and ordinances.

WARNING - Improper connection of the equipment-grounding conductor can result in a risk of electric shock. Check with a qualified electrician or service person if you are in doubt as to whether the outlet is properly grounded. Do not modify the plug provided with the appliance – if it will not fit the outlet, have a proper outlet installed by a qualified electrician.

Note: In Canada, the use of a temporary adapter is not permitted by the Canadian Electrical Code.

UN-PACKAGING MACHINE

Your Powr-Flite® Floor Machine was protectively packed to prevent damage in shipment. We suggest that upon removing the unit from its carton, you carefully inspect it for any possible damage in transit. If damage is discovered, immediately notify the transportation company who delivered your machine. As a manufacturer, we are unable to act upon any claim for concealed damage; you must originate the claim.

IMPORTANT SAFEGUARDS

This machine is designed to be safe when used to perform the functions specified in this Operator's Manual. Should damage occur to electrical or mechanical parts, the machine should be repaired by the manufacturer or competent service station before using to avoid further damage to the machine or physical injury to user. Your floor machine is equipped with a safety switch lockout device designed for your safety. Do not attempt to bypass or defeat the safety lockout device. Never use any device to lock the power switch triggers in the ON position.

THIS MACHINE IS NOT A TOY. FAILURE TO FOLLOW SAFETY PROCEDURES AND INTENTIONAL MISUSE COULD RESULT IN DAMAGE TO THE MACHINE OR USERS. FOLLOW ALL SAFETY INSTRUCTIONS.

OPERATING INSTRUCTIONS

MACHINE COMPONENTS

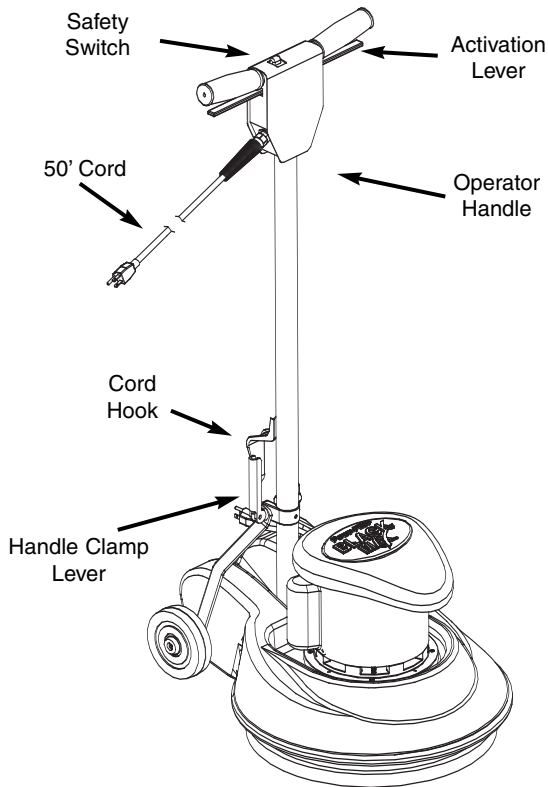

MACHINE OPERATION

1. Carefully unwrap power cord and check for tangles and knots and plug into a properly grounded outlet.
2. Pull up on the handle clamp lever to unlock handle, adjust handle to the lowest comfortable position.
3. Push down on the handle clamp lever to lock handle in place.
4. Place both hands on the operator handle, place the right thumb of the safety switch and press. Gently squeeze the activation lever.
5. Begin operation.

MAINTENANCE

After Use:

Clean all surfaces of the machine and carefully wrap cord under the cord hook and over the handle. Remove pad driver or brush.

Monthly:

Inspect cord for damage. Tighten strain relief.

Annually:

Replace cord and strain relief. Service carbon brushes at authorized service center.

INSTALLING PAD DRIVERS & BRUSHES

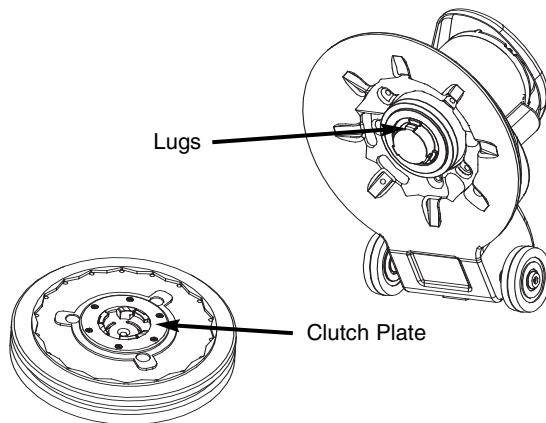

Align the notches in the clutch plate with the lugs. Insert lugs into clutch plate and turn counter clockwise until the clutch plate locks into place. To remove, give a quick, hard turn clockwise.

PAD DRIVERS & BRUSHES SIZING

The 17" and 20" floor machines will accept full 17" (17" machine) and 20" (20" machine) pad drivers and brushes without the use of a riser. However, certain specialty accessories may require use of a riser and/or a smaller block to avoid interference with the housing.

PARTS LIST

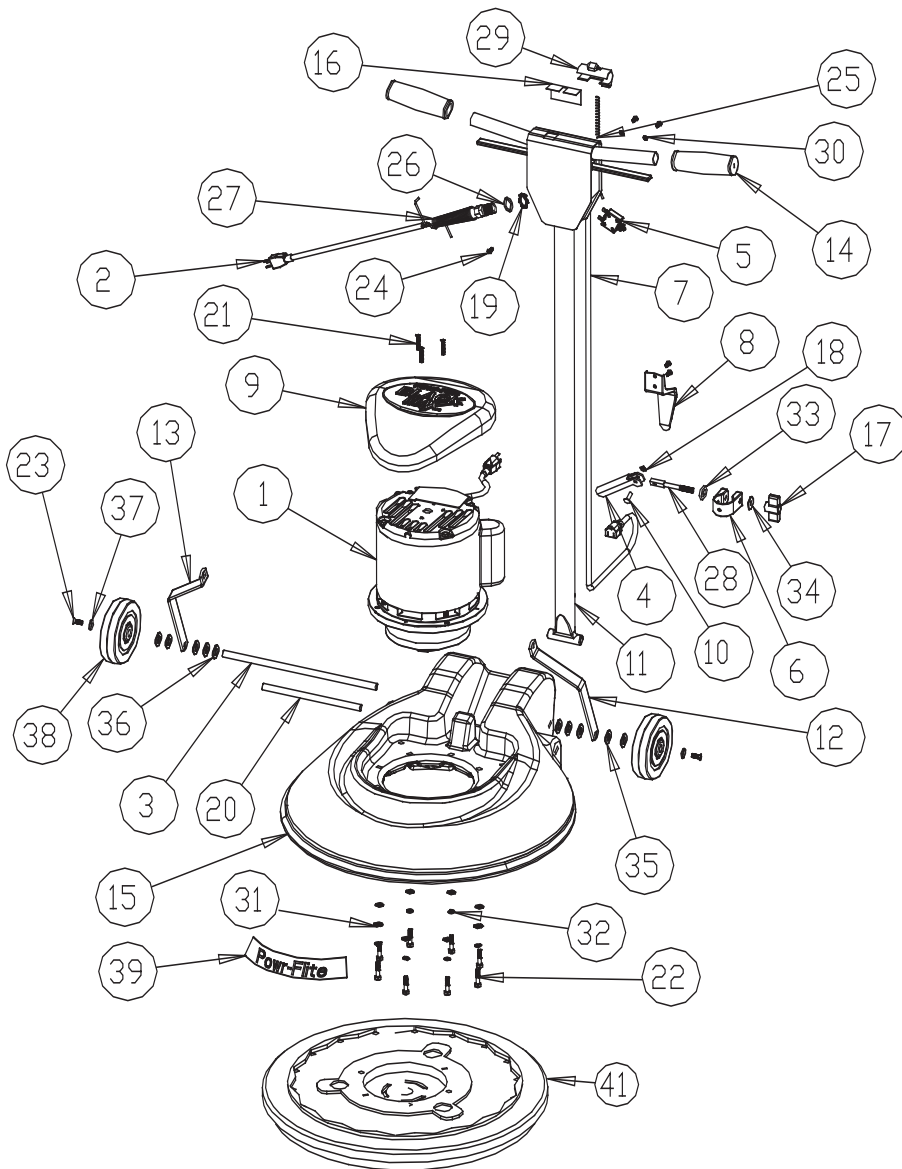

REF#	DESCRIPTION	ITEM #
1	175 rpm, 1 hp motor	X8981
	175 rpm, 1.5 hp motor	X8980
	175/320 rpm, 1.5 hp motor	X8071P
2	50' 14/3 STWA cord	M1369G
3	axle	X8936
4	cam lever handle	X8014
5	15a circuit breaker	X8023
6	handle clamp collar	X8012
7	4' 14/3 STWA cord, black	X8989
8	cord hook	X8013
9	motor cover	X9420
10	dowel pin	X8031
11	handle assembly	X8911
12	left handle brace	X8807L
13	right handle brace	X8807R
14	handle grip	X8941
15	17" housing	X9418
	20" housing	X9419
16	insulation sheet	X8923
17	handle clamp knob	X8016
18	1/4" lock nut	X8032
19	1/2" lock nut	X8008N
20	pivot pin	X8977
21	10 - 32 X 1 1/4" screw	X9422
22	1/4 - 20 X 1 1/4" screw	X8226
23	1/4 - 20 X 3/4" screw	X8265
24	10 - 24 X 1/2" screw	X8207
25	safety trigger spring	X8915
26	strain relief washer	SR36
27	strain relief	SR37
28	cam lever stud	X8015
29	safety trigger switch	X8914
30	#10 tooth washer	7CY001
31	1/4 flat washer	X8235
32	1/4 split lock washer	X8212
33	slotted cam washer	X8028
34	5/6" X1" washer	X9374
35	nylon washer	X8108
37	countersunk axel washer	X8020
38	5" wheel	X8024
39	label	X8400C
40	17" pad driver	TPD17
	20" pad driver	TPD20

Limited Warranty

The manufacturer warrants to the original purchases that products manufactured are free from defects, provided such goods are installed, operated and maintained in accordance with written manuals or other instructions, for a period of lifetime on the housing, 5 years on the motor, 3 years on the transmission, 1 year on all other parts and workmanship, from date of original purchase.