

PROPANE BURNISHER/STRIPPER

OPERATOR'S MANUAL

**Models: P2113, P2114-ON
P2117, P2717, P2720-ON
P3013, P3014-ON, P3017**



WARNING:

OPERATOR MUST READ AND UNDERSTAND THIS MANUAL COMPLETELY BEFORE OPERATING THIS EQUIPMENT.

Congratulations on your purchase of a Powr-Flite propane burnisher/stripper. Read this entire manual before operating or servicing the machine

Unpacking Your New Propane Machine (Shipping and Damage)

Your Propane burnisher/stripper was thoroughly inspected, tested, and packaged to deliver the equipment in good operating condition. The freight carrier received and signed for the equipment in good condition. Damage can occur during shipping and to protect your interest, all cartons must be inspected for damage (including any concealed damage) that might have occurred during shipment. Any damage is the responsibility of the freight carrier and should be reported immediately to the carrier. It is your responsibility to issue a claim and to receive compensation from the freight carrier for any damage done in transit. Shipping damage is not warranted.

MACHINE DATA

Please fill out at time of purchase for future reference.

Model No.- _____

Purchase Date- _____

Serial No.- _____

GENERAL INSTRUCTIONS

Propane gas is a convenient and versatile fuel that has been safely used in a number of applications for residential, commercial and industrial applications. Propane gas is non-toxic, so it's not harmful to soil and water and is not regulated by the Environmental Protection Agency. Propane is however a flammable gas and must be handled with caution.

Propane provides a more efficient fuel for burnishing than electric burnishers/strippers. Propane gas also runs cleaner than regular automotive gas and can be safely stored for extended periods of time in UL approved storage tanks. Propane tanks should be properly inspected on a regular basis, checking for leaks and any damage that may affect the use of the tank. There are numerous filling and inspection centers available to provide for your LP gas needs.

Being aware of and following safety precautions can reduce the risk of using propane to an almost negligible amount. Propane has a very good safety record due in part to the stringent codes and regulations developed by the propane industry in conjunction with the National Fire Protection Association (NFPA). Every aspect of propane handling is covered by NFPA to

assure worry-free operation. The propane gas used in the Powr-Flite burnisher/stripper is no different than the propane gas used for many years in various industries. Some of the well known uses include fork lifts, campers, gas grills, etc. Caution and care in the operation of any equipment prevents unnecessary risks and accidents.

Propane Defined

Propane is liquefied petroleum gas (LP Gas), a fuel used in combustion engines. LP Gas is heavier than air and will concentrate in the lowest available areas. LP Gas also vaporizes at temperatures above its boiling point of 44°F. LP gas vapors look like steam, but can freeze the skin due to the extreme coldness of the vapors. Avoid contact with skin by wearing gloves and other protective clothing when using propane gas.

The Nature of Propane

Propane can be either a liquid or a gas. At normal atmospheric pressure and temperature, it is a non-toxic, colorless and odorless gas. Just like natural gas, an identifying odor is added so it can be readily detected. Under moderate pressure, propane becomes a liquid that vaporizes into a clean-burning gas when released from its storage container.

Propane Carburetion System

Propane buffers are powered by a propane vapor withdrawal carburetion system in which the gas vapor is forced from the top of the tank into the fuel line by natural pressure. The vapor then passes into a fuel lock off device, which stops fuel flow when the engine is not running. From the lock off device the gas flows through the two-stage gas regulator, which reduces the pressure to approximately 5 p.s.i. in the first stage it is then further reduced to almost atmospheric pressure in the second stage. From the regulator, the fuel flows into the engine through the carburetor spud-in where air is mixed with the fuel in proper ratios for complete combustion.

SAFE USE AND HANDLING OF PROPANE BURNISHER/STRIPPER

When using the propane burnisher/stripper, basic safety precautions should always be followed. The following recommendations are designed to protect the safety of the operator, other people in proximity to the machine and the equipment itself. These safety guidelines must be followed at all times to avoid potential serious personal injury and damage to the unit.

The use of propane gas requires that specific safety precautions be understood and followed for safe operation. The safety instructions in this manual provide the basic guidelines for handling propane. It is, however, recommended that employees handling propane be trained in all aspects of the safe usage of propane.

Purpose of Safety Training

- ▲ To inform and educate end users on the safe handling and operating procedures for propane powered floor care equipment.
- ▲ To clarify common misconceptions about the safe use of propane.
- ▲ To make all users of propane equipment aware of the NFPA's recommended standards.

Certification

Based on recommendations by the National Fire Protection Association (NFPA) guidelines have been established for the use of propane gas. NFPA 58, Standard for Storage and Handling of Liquefied Petroleum Gases, Chapter 1, Section 6 states that: "In the interest of safety, all persons employed in handling LP-Gases shall be trained in proper handling and oper-

ating procedures, which the employer shall document. Effective Jan. 1, 1993, all employees shall carry written certification of their job qualification issued by the training agent or a written document issued by the authority having jurisdiction identifying the functions each person is authorized to perform."

Local regulating authorities define the specific requirements for certification in each area. To become certified, you must complete the safety course recommended by the NFPA, read the safety handbook, view the safety video and successfully completed the safety exam. Check with local regulating authorities to determine certification requirements.

Safety Precautions

The propane burnisher/stripper is intended for use only as described in this manual. Using the propane burnisher/stripper in any manner not described in this manual can void the warranty. Use only manufacturer's recommended accessories.

1. Exercise care in all aspects of the use and handling of the propane burnisher/stripper. Propane gas is extremely flammable and is explosive under certain conditions.
2. All operators must participate in a safe handling and operation course authorized by the manufacturer of the unit.
3. The propane burnisher/stripper must be maintained in accordance with the manufacturer's recommended maintenance procedures, in a safe operating condition, and the owner must maintain a record of the maintenance for a period of two years.
4. The exhaust from the propane engine contains toxic carbon monoxide gas. Avoid inhalation of exhaust gasses. Never run the engine in a closed garage or confined area without proper ventilation. Severe respiratory damage or asphyxiation can result. Consult with your regulatory authorities for the exposure limits. Keeping the engine properly tuned will lower exhaust emissions.
5. Do not connect and/or disconnect propane cylinders unless the machine is in a well ventilated area with no source of ignition within 10 ft. (3m) from the point of connection.

6. A propane machine can only be used in buildings:
 - I. Provided with continuous mechanical ventilation that removes the products of combustion to the outdoors of not less than 300 CFM for each 10,000 Btu input or fraction thereof;
 - II. Provided with natural ventilation of not less than 300 CFM for each 10,000 Btu input or fraction thereof, based on a maximum of one quarter air change per hour for the net building volume.
7. Check the fuel supply system and propane tank connections of the propane machine for leakage immediately after a propane tank is connected.
8. The propane machine moves when the motor is running. Always stop the motor before leaving the machine.
9. Do not store the propane machine outdoors. Avoid getting the machine wet.
10. When a propane machine is not in use and/or stored indoors, the propane tank must be removed and stored according to the instructions to Handling and Storing Propane.
11. The propane tank must be securely fastened with the system valve closed before the machine is transported.
12. The propane machine with tank installed must always be located in a well ventilated space.

CAUTION

Read All Instructions, Warning and Cautions Before Using

These guidelines are provided for your protection and convenience. Please read them carefully. If you have any questions regarding the use of your equipment call 1.800.880.2913. Failure to adhere to provided instructions can potentially void any warranties. Precautions and safety warnings are provided for your protection. Failure to observe these warnings could result in personal injury and damage to the equipment. When using an electrical appliance, basic safety precautions should always be followed.

WARNING

TO AVOID FIRE, DO NOT USE WITH A FLAMMABLE OR COMBUSTIBLE LIQUID TO CLEAN FLOOR

PROPANE TANK STORAGE, HANDLING AND USE

The propane tanks or cylinders used with propane burnishers/strippers are designed with the components necessary for UL approval. The machine should not be operated with tanks that are not UL approved for machine use. Do not substitute tanks with those designed for gas grills or other uses. They are not designed for the propane machine and can create dangerous operating conditions.

Storing Propane Tanks

Propane tanks should always be stored in a well-ventilated area. Never store propane gas tanks in concealed locations such as closets, supply rooms, etc. Storing the propane gas tank with the machine in an enclosed area is prohibited by the NFPA due to the potential for a fire. Propane gas can start a B.L.E.V.E. (Boiling Liquid Expanding Vapor Explosion) in elevated temperatures. Exposure of the tank to heat can also cause the relief valve to open, that would release flammable vapors causing fire to intensify when ignited.

ATTENTION: Tanks (20 lb.) should not be stored in buildings used by the public or frequented by anyone passing through or working in the building. Safety codes allow inside storage of propane tanks in buildings designated as shop or machinery facilities that meet specific requirements.

Section 5-2.1.1 of the NFPA 58 states: "Containers in storage shall be so located as to minimize exposure to excessive temperatures rise, physical damage or tampering." An ideal storage facility is an outdoor "open" enclosure that is secure, tamper proof and provides safety from accident or vandalism. All storage facilities must be properly labeled. Outdoor facilities must be no closer than 5 feet to the nearest building opening. If the storage facility is enclosed, it must allow for venting at both the floor level and higher to allow gas vapors to disperse. At normal atmospheric pressure and temperature, propane gas is non-toxic, colorless and odorless. An identifying odor is added so it can be readily detected even in at very low concentrations.

Propane tanks must always be stored in an upright position. Under moderate pressure, propane becomes

a liquid that vaporizes into gas when released for the tank. The upright position assures that any discharge is largely vapor rather than liquid. The escape of vapor presents less of a hazard than liquid. The vapor will be dissipated rather than settling into pockets (in properly vented storage facilities) with the possibility of an explosion and/or fire. The upright position also provides relief to the pressure relief device.

A sign indicating "NO SMOKING" shall be permanently displayed at the storage area. The sign shall be in accordance with the sign required in Clause 10.12.3 of CAN/CGA-B149.2-M91, Propane Installation Code. (Does not apply in industrial buildings).

NOTE: Local jurisdiction will transcend general regulations on storage of propane tanks. Contact your local authorities to ensure compliance to all code requirements.

Indoor Storage

If storage is in a shop or machine storage area that is connected or a part of an office complex, it should be separated by a firewall along with proper venting to the outside. If tanks are stored inside a building, the building must be vented at floor level and at higher levels, so that the gas will be dispersed rather than settling to the lower levels and posing a risk of explosion.

There are significant regulations for inside storage of propane tanks. Local codes will dictate what guidelines must be followed. Contact your local authorities to ensure compliance to all code requirements.

The manufacturer recommends removing the tank after using the machine and storing it in an approved tank storage facility. The machine can then be stored in a secured inside storage area.

Refueling Propane Gas Tanks

The propane gas tank supplied with the machine has a 20 lb. (9.3kg), 5 gallon (18.9L) capacity. The manufacturer exclusively uses steel cylinders which meet the Department of Transportation guidelines contained in the D.O.T. # 4ET240 and are U.L. Listed. Use only D.O.T. and U.L. Listed propane tanks. Refuel only at qualified propane dealers. **DO NOT OVERFILL.** Overfilling the tanks could cause injury to the operator and damage to the equipment.

For supporting information, see NFPA 58 (Chapter 4) on the refueling of propane tanks. A major concern of refilling is overfilling the tank. Propane tanks have a safety relief valve to release pressure by venting vapor from the top of the tank. If the tank is filled completely to the top, this safety measure is compromised. Propane gas expands in changing temperatures. Overfilling the tank does not allow for the expansion of the gas. An increase in air temperature will drive up the cylinder pressure which will place stress on the tank. Before reaching a critical pressure point, the relief valve should open, relieving the pressure. If the tank is overfilled, liquid can be released when the relief valve opens. Liquid propane flowing from the hose and down into the regulator can result in damage to the machine. Overfilling the tank can also freeze the regulator causing it to function incorrectly.

Frost on the regulator is an indication that the tank has been overfilled. Take the tank to a safe outside location and vent the excess propane. This is accomplished by:

1. Remove the propane tank from the machine.
2. Take the tank outside of the building to a safe area.
3. Open the small relief valve located on the top of the machine.
4. Keep the tank upright.
5. Allow to vent until fuel vapor is not visible.

SAFETY: Propane gas vapors can freeze your skin. Avoid contact with skin by wearing gloves and other protective clothing.

Always make sure an authorized person fills the tanks to the proper amount. Propane tanks can be filled by volume using a gauge, but the gauge on the tank is only an indicator and may not accurately reflect the amount of gas in the tank. The most accurate way to fill the tank is by weight. Tanks should be filled to only 80% of capacity. Having additional tanks will allow the machine operator to simply exchange tanks when necessary and refueling can be accomplished away from your site.

Empty tanks should be handled with as much caution as full tanks, because a tank is never completely empty. There will always be residual gas vapors in the

tank, which may pose a hazard if not properly handled. Treat all tanks as filled tanks.

Propane Machine Operation

All machine operators should be properly trained in the handling and use of propane, as well as the safety precautions to be followed, as covered in this handbook. All operators should also read the engine's owner's manuals before attempting to operate the equipment.

Machine Setup

1. Checking oil levels and filters **ALWAYS \ CHECK OIL DAILY BEFORE USING MACHINE.**
2. Check oil level prior to starting machine. When checking oil, machine should be turned OFF and on level surface. Remove the dipstick and wipe clean. Replace the dipstick but do not screw in. Fill cap should be fully screwed out and free. Do not check oil by screwing cap in and then out again. This will give a false reading.
3. After checking oil level and determining that the oil level is low, add oil using the proper amount and specified oil to prevent engine damage. The manufacturer recommends the use of 10W30 oil. When filling or changing oil, add no more than one quart (946.3ml) – then check dip stick in cap. Add additional oil if necessary, but do not overfill.
4. Be sure air filter is free of dust/debris and other obstructions.
5. Check and clean recoil and carburetor filters if necessary. (See Engine Owner's Manual).

Adjusting Handle Height

1. Use a 9/16" wrench to adjust the handle at the pivot points until the desired operating position is reached.
2. Tighten the bolts at the desired position.

Installing or Changing Propane Fuel Tank

1. Push machine to a designated safe area.
2. Close LPG tank valve on installed tank.
3. Put gloves on and remove service couple by turning

counter-clockwise.

5. Unlatch and remove empty propane tank from machine and store in a designated, safe area.
6. Carefully put full propane tank on machine and position valve nozzle towards engine. Make sure the propane tank matches the type of fuel system (liquid tank with liquid system).

SAFETY: Never release or bleed tank inside building or in enclosed areas.

SAFETY: When servicing machine, keep flames and sparks away from fuel service area.

SAFETY: Always service the machine in a well ventilated area.

Installing or Removing Pad Driver and Pads

Pad Driver Installation:

1. Lean machine on right side (dip stick tube down).
2. Place pad driver on drive shaft and spin pad driver clockwise to install.

Pad Installation:

1. Tilt machine back onto rear caster (Park Position).
2. Remove plastic center lock ring from pad driver.
3. Center pad on pad driver and secure with center lock ring.

Pad Driver Removal:

1. With knee, apply downward pressure on bell of machine deck.
2. Place 3/4" (19mm) open end wrench on to top of drive shaft.
3. With rubber mallet, strike wrench to break loose shaft from pad driver (counterclockwise).
4. Lean machine on right side (dip stick tube down).
5. Remove pad driver by spinning off counterclockwise.

MACHINE OPERATION

SAFETY: Do not operate machine unless Operation Manual is read and understood.

Starting Procedures

1. With machine on level surface check oil. Oil must be in machine before starting.
2. Be sure air filter is free of dust/debris and other obstructions.
3. Tilt machine back onto rear caster (Park Position).
4. Center and secure buffing pad on drive pad.
5. Remove any packing materials and obstructions from drive system.
6. Turn propane fuel ON at the tank. Check propane gas level meter.
Note: Opening service valve quickly may cause service check valve to stop flow of propane fuel. If check Valve stops fuel flow, close service valve, wait a few seconds and open valve slowly.
7. Push throttle to the choke position. The engine starts in IDLE position. For Electric start model: Plug in the electric starter (follow safety recautions for electrical use)
8. Push START button or turn key (if equipped) to engage starter. Do not engage starter button for more than 20 seconds at a time. If the starter verheats, it trips an internal overload switch and will not crank over. Wait at least 20 to 30 seconds between tries.
9. When engine starts, ease throttle back to running position. Do not hold starter button in a continuous ON position. Doing so will burn out the starter.

Stopping Procedures

1. Turn propane gas OFF at the tank. This serves to purge or bleed the fuel hoses and carburetion system of fuel, so that there is no danger of gas escaping from the lines when the tank is removed for outside storage.
2. Tilt machine back on rear caster.
3. Engine will stop running when fuel lines bleed clear.
4. Pull throttle to STOP position after engine has stopped.

Emergency Stopping Procedures

1. Pull throttle back to STOP.
2. Turn propane gas OFF at the tank. NOTE: Engine may backfire when stopped in this manner.

MAINTENANCE

Preventative maintenance is key to the continued safe and reliable operation of your propane machine. These guidelines will keep your machine in optimum operating condition

1. Before attempting any maintenance procedures on machine, stop on level surface, shut off machine and turn off propane valve at tank.
2. Repairs and adjustments must be performed by authorized and trained personnel.
3. Always record maintenance and service.
4. Always keep machine free from dust and lint; the engine is air cooled and for proper air flow to cool the engine, the recoil filter must remain clean.

Daily Maintenance (Every 4 Hours of Operation)

1. Check oil level (Use 10W30 oil only)
2. Clean recoil filter.
3. Check belt tension by pinching belt together. Belt should only depress 1/2" (13mm).
4. Clean all air filters by blowing out dust and dirt and/or washing the foam filters (recoil and carburetor pre-filter) with warm, sudsy water and rinsing clean. (Be careful not to wet the paper carburetor filters.) Be sure filters are clean and dry before use. Do not oil foam or filter.
5. Make sure all components are secure and tight.
6. Check pad daily (clean or replace).
7. Clean machine.

Weekly Maintenance (Every 20 Hours of Operation)

1. Check oil level. Change oil and filters at 50 hrs of operation. Use 10W30 Motor Oil or other no ash motor oils designed for use in engines. Use of non-recommended oil may void the engine warranty.
2. Inspect carburetor air filter by removing wing nut and cover on top of carburetor. Replace if dirty or deposits are present.

3. Check belt for tension. Tighten if loose. If worn, replace with proper belt. (See "Adjusting Belt Tension") Refer to parts schematic for size of belt required.
4. Inspect and tighten nuts and bolts on engine and frame.
5. Examine all propane hoses and connections for leaks or wear. Replace if necessary.
6. Grease wheels. Use white lithium grease only and use no more than 1 pump of grease. More grease than recommended will push seal and dust cover out, allowing dust and other foreign materials into the bearings, shortening the life of the wheel significantly.

Quarterly Maintenance (Every 250 Hours of Operation)

1. Perform all of the above maintenance procedures and have engine checked by an Authorized Service Center.
2. Check air gap in electronic ignition coil.
3. Check valves with engine cold.

NOTE: Consult Engine Manual for complete servicing and adjustments information.

Life of the Machine

1. Change oil regularly.
2. Clean recoil filter regularly.
3. Clean carburetor filter regularly.
4. Keep machine clean from dust and debris.

Fuel System

Adjustments for the air/fuel mixture must be made by an Authorized Service Center. Improper adjustments can cause high levels of carbon monoxide emissions which may cause carbon monoxide poisoning or it can lead to engine damage.

Changing the Oil

1. The manufacturer recommends 10W30 oil.
2. Run engine for five minutes to warm oil.
3. Make sure machine is on level surface. Locate oil drain plug on rear of engine beside oil cap and remove by turning counter-clockwise with wrench.

4. Allow oil to run into pan under machine. Allow to completely drain.
5. Install drain plug and tighten drain plug by turning clockwise with wrench.
6. Slowly add one quart (946.3 ml) of 10W30 Motor Oil. Then check oil level with dip stick in oil fill cap. Add additional oil if necessary.
7. Replace oil-fill cap assembly. Hand tighten only.

ATTENTION: Do not overfill and never run engine low on oil.

ATTENTION: When checking oil, be sure cap is fully screwed out and free. Do not check oil by screwing cap in and then out again, this will give you a false reading.

Adjusting the Belt Tension

1. Loosen the Mounting Bolt of the top side of the machine while applying counter-pressure to the Adjusting Nut on the underside of the deck.
NOTE: The Mounting bolt must be loosened first.
2. Rotate the Adjusting Nut counterclockwise with a socket to apply tension to the belt.
3. While holding the tension on the Adjusting Nut, tighten the Mounting Bolt.
4. Check the belt tension by pinching the belt together. The belt should only depress 1/2" (12mm).

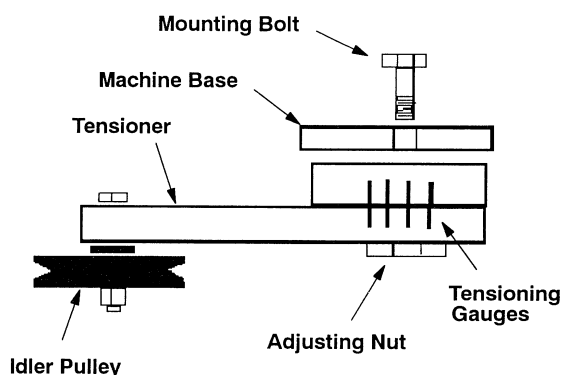

Storing Machine

1. Remove LPG tank from machine when not in use.
(Note: See “Installing or Changing Propane Fuel Tank” for specific instructions on tank removal.)

SAFETY: Never release or bleed tank inside building or in enclosed areas.

2. Perform all Daily Maintenance procedures.
3. Change engine oil.
4. Store machine in cool, dry area, away from fuel tanks. Tilt machine back onto rear caster (Park Position).
5. Store tanks in an approved area. Note: See “Storing Propane Gas Tanks” for specific instructions on tank storage.

Transporting Machine

For ease of transportation, the machines handle can be folded over the engine. The tank can be transported on machine provided that tank hold-down clamp is securely fastened around tank and tank valve is turned completely OFF.

SAFETY: Never transport a machine in an enclosed area that has not had sufficient time to cool down.

Trouble Shooting Guide

| PROBLEM | CAUSE | SOLUTION |
|-------------------------|--|---|
| Will not start. | No fuel or dirt in fuel line. | See Engine Owners Manual for servicing. |
| | Blown head gasket. | |
| | Engine overload. | |
| | Dirty air cleaner. | |
| | Faulty spark plug | |
| | Fuel system out of adjustment. | |
| | Defective ignition coil. | |
| Hard to start. | Improper fuel, no fuel or dirt in fuel line. | See Engine Owners Manual for servicing. |
| | Engine overload | |
| | Dirty air cleaner. | |
| | Faulty spark plug. | |
| | Spark plug or head bolts loose. | |
| | Blown head gasket. | |
| | Timing, coil or valve need adjusting. | |
| | Carburetor needs adjusting. | |
| | Regulator needs adjusting. | |
| | Insufficient vacuum. | |
| Lacks power. | Improper valve clearance. | See Engine Owners Manual for servicing. |
| | Improper fuel or dirt in fuel line. | |
| | Faulty spark plug. | |
| | Improper oil level. | |
| | Valve seats need adjusting. | |
| | Leaking head gasket. | |
| | Governor needs adjusting. | |
| | Worn rings. | |
| Smell of burned rubber. | Belt out of adjustment. | See "ADJUSTING BELT TENSION" |
| Engine overheats. | Dirt in fuel line. | See Engine Owners Manual for servicing. |
| | Incorrect oil level. | |
| | Engine overload. | |
| High fuel consumption. | Dirty air filters. | See Engine Owners Manual for servicing. |
| | Dirty air cleaners. | |
| Machine stops suddenly. | Faulty spark plug. | See Engine Owners Manual for servicing. |
| | Pad not centered on pad driver. | |
| | Incorrect pad size for pad driver. | |
| | Oil shut down sensor activated. | Add recommended oil. |
| Excess vibration. | Bolts loose on engine or deck of unit. | See Engine Owners Manual for servicing. |
| | No fuel or dirt in fuel line. | |
| | Incorrect oil level. | |
| | Engine overload. | |
| | Dirty air filters. | |
| | Faulty spark plug. | |

Illustrated Parts List for P2717 and P2720 Models

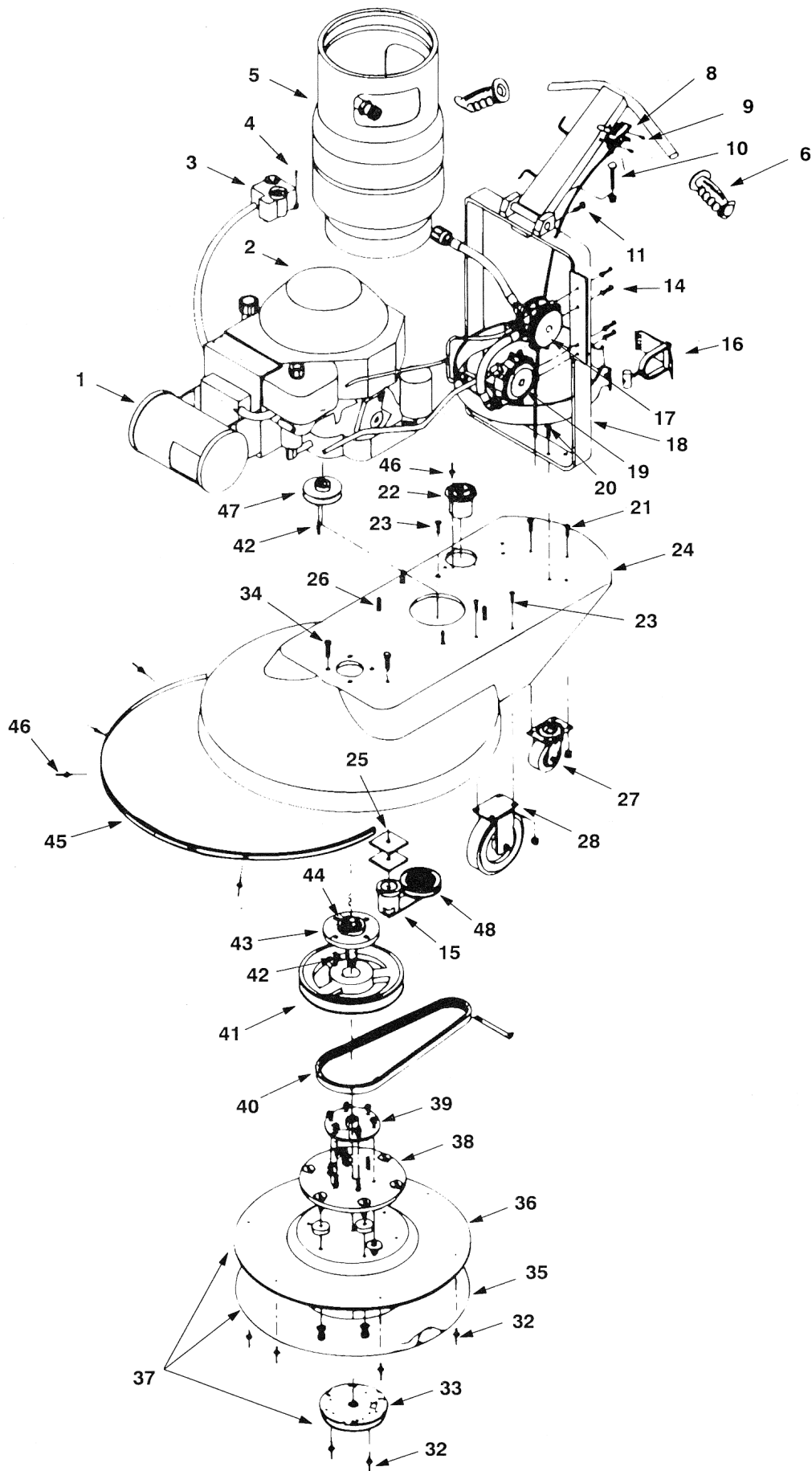

Illustrated Parts List for P2113, P2114 AND P2117 Models

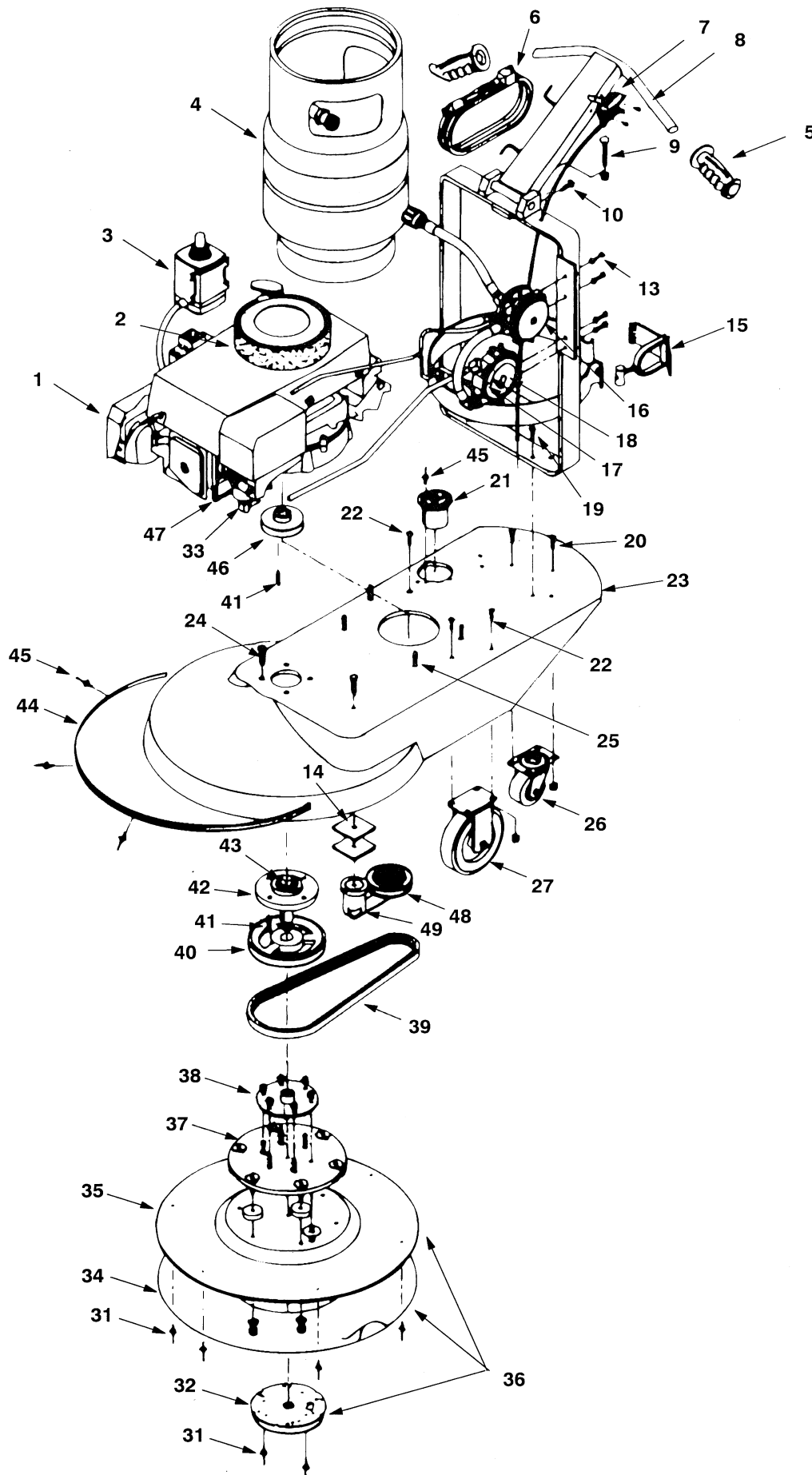

Illustrated Parts List for P2113, P2114 AND P2117 Models

| Ref. | Part No. | Description |
|------|----------|------------------------------|
| 1 | * | HONDA GXV 340 ENGINE 13 HP |
| | * | KAWASAKI 494 CC ENGINE 17 HP |
| | * | ONAN 390 CC ENGINE 14 HP |
| 2 | P1011 | AIR FILTER (HONDA) |
| | P1012 | AIR FILTER (KAWASAKI) |
| | P1013 | AIR FILTER (ONAN) |
| 3 | P1550 | STARTER, 110V (HONDA) |
| | * | STARTER, 12V (KAWASAKI) |
| | P1125 | STARTER, 12V (ONAN) |
| 4 | P1705 | TANK, STEEL 20 LB. LP |
| 5 | P1010 | GRIPS, HANDLE 2 |
| 6 | P1555 | CORD, EXTENSION |
| 7 | P1015 | CONTROL, THROTTLE 48" |
| 8 | * | SCREW, #8X112 |
| 9 | * | BOLT, 318X2 14 |
| 10 | * | BOLT, 318XI |
| 12 | * | SCREW, 10-32XI |
| 13 | * | WASHER, LOCK |
| 14 | * | SPACER, TENSIONER ARM |
| 15 | P1003 | TOGGLE |
| 16 | * | LOCKOFF |
| 17 | * | HANDLE |
| 18 | P1156 | REGULATOR |
| 19 | * | NUT, NYLOCK5/16X1 114 |
| 20 | * | NUT, NYLOCK 114X314 |
| 21 | P1240 | METER, HOUR |
| 22 | * | BOLT, 5116XI |
| 23 | * | DECK, ALUMINUM 21" |
| 24 | * | SCREW, 7116-20XI |
| 25 | * | BOLT, 5116-24XI (HONDA) |
| 25 | * | BOLT, 13MMX30MM (KOHLER) |
| 26 | P1210 | CASTER, REAR SWIVEL |
| 27 | P1200A | WHEEL, 6" WIBRACKET |

| Ref. | Part No. | Description |
|------|----------|--|
| 32 | P1410 | CENTER LOCK |
| 33 | P1127 | ADAPTER, SPUD-IN (HONDA) |
| 36 | P1126 | DRIVER, PAD W/FACE 8. CENTER LOCK 21" |
| 39 | PBX38 | BELT, B X 33 |
| 40 | P1310 | PULLEY, 6.2" |
| 41 | P9075 | KEY, STOCK 114 2 |
| 42 | P1372 | BEARING FRONT HOUSING |
| | P1380 | BEARING, FRONT ONLY |
| 43 | P1352 | SHAFT, DRIVE |
| 44 | P1621A | MOLDING, BUMPER |
| 45 | * | RIVET, POP SMALL |
| 46 | P1235 | PULLEY, ENGINE 3 5' |
| 47 | * | TUBE, VACUUM (HONDA) |
| 48 | P1235 | PULLEY, IDLER |
| 49 | P1230 | ARM1 TENSIONER LOVEJOY |

NOT ILLUSTRATED

| | |
|-------|---------------------|
| P1121 | SPARK PLUG HONDA |
| P1122 | SPARK PLUG ONAN |
| P1123 | SPARK PLUG KAWASAKI |
| P1114 | DIP STICK HONDA |
| P1115 | DIP STICK ONAN |
| P1116 | DIP STICK KAWASAKI |
| P1117 | OIL FILTER HONDA |
| P1118 | OIL FILTER ONAN |
| P1119 | OIL FILTER KAWASAKI |

PREVENTATIVE MAINTANCE KITS

| | |
|-----|----------------|
| PM1 | ONAN 20 HP |
| PM2 | ONAN E124 |
| PM3 | HONDA GXV390 |
| PM4 | KAWASAKI 17 HP |

*Call for part number and pricing.

Illustrated Parts List for P3013, P3017-ON and P3017

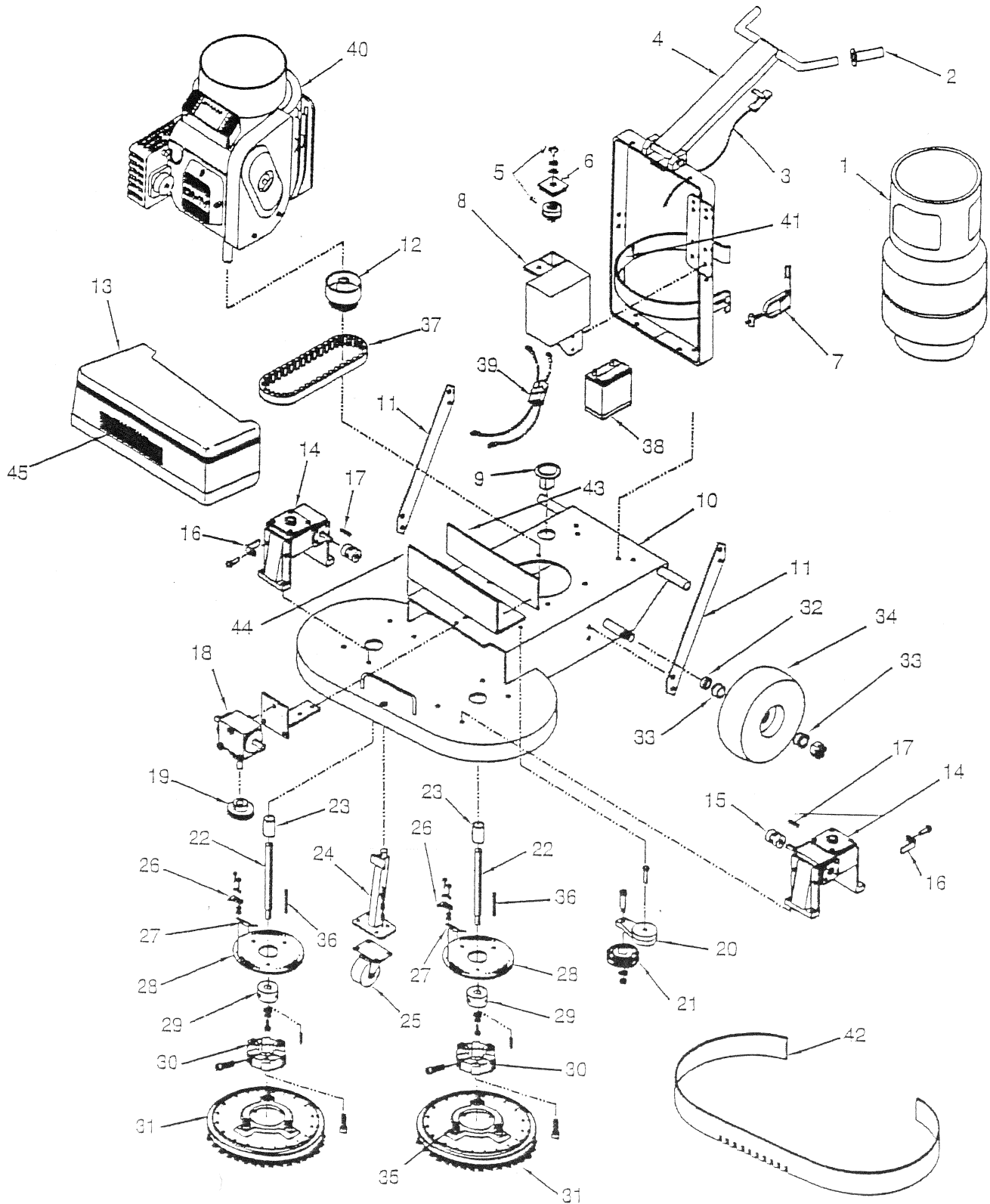

Illustrated Parts List for P3013, P3017-ON and P3017 Models

| Ref. | Part No. | Description | Ref. | Part No. | Description |
|------|----------|-----------------------------|------|----------|---------------------------------|
| 1 | P1705 | LP Tank | 24 | * | Transport Wheel |
| 2 | P1010 | Hand Grips | 25 | * | Swivel Caster |
| 3 | P1015 | Throttle Cables | 26 | * | Brush Plate Clamp |
| 4 | * | Handle | 27 | * | Sprins Clip |
| 5 | * | Switch, Key | 28 | * | Mounting Plate Twin Head |
| 6 | * | Key Switch Housing | 29 | * | Aluminum Hub |
| 7 | * | Toggle | 30 | * | Centra Flex |
| 8 | * | Battery Box with Key Switch | 31 | * | Strip Brush (1 set) |
| 9 | P1240 | Hour Meter | 32 | * | Wheel Spacer 1/2" |
| 10 | * | Twin Head Strip Frame | 33 | * | Delrin Bearing 1" |
| 11 | * | Handle Gussett | 34 | * | Wheel 10" Air Filled |
| 12 | * | Centrifugal Clutch 1 | 35 | * | Lugs L-800 |
| 13 | * | Hood Assy. Twin (Aluminum) | 36 | * | Key Stock 1/4 x 1/4 x 1 1/4 |
| 14 | * | Gear Box Twin Head | 37 | * | Belt BX49 |
| 15 | * | Coupler Shaft | 38 | * | Battery, 12 Volt |
| 16 | * | Bracket, Hood Assy | 39 | * | Battery Connector E124 |
| 17 | * | Key Stock 3116 | 40 | * | Onan E124 Fuel Injection Engine |
| 18 | * | M-2 Center Gear Box | 41 | * | Velcro Tape |
| 19 | * | 7.0 x 5/8 Pulley | 42 | * | Splash Guard TrackKer |
| 20 | * | Tensioner Arm | 43 | * | Heat Shield Foil Material |
| 21 | * | Idler Pulley | 44 | * | Heat Shield Support Plate |
| 22 | * | Drive Shaft | 45 | * | Expanded Metal Plate 4 1/2x 14 |
| 23 | * | Spacer, Orive Shaft | | | |

Warranty Policy

The manufacturer warrants to the original purchaser that products manufactured are free from defects of workmanship and material under normal use and service for a period of two years from date of purchase provided such goods are installed, operated and maintained in accordance with written manuals or other instructions. Specified items subject to normal wear are warranted for a period of 90 days. These items include bearings, belts, handgrips, starters, and throttle cable. Parts replaced under the warranty period are fully warranted for the remainder of the original warranty period.

This warranty is null and void on any part(s), which has been subject to alteration, accident, abuse or misuse. The warranty is valid only to the original using purchaser. Contact your Powr-Flite representative for any issues regarding warranty coverage.

This warranty does not include engines which are warranted by the engine manufacturer as follows: Honda – two years, Onan – three years, Kawasaki – three years.



A Tacony Company
3101 Wichita Court • Ft. Worth, TX 76140-1710