

# Predator Automatic Scrubber

## OPERATORS MANUAL AND PARTS LIST

### Model PAS28R



**WARNING: OPERATOR MUST READ AND UNDERSTAND THIS MANUAL COMPLETELY BEFORE OPERATING THIS EQUIPMENT.**

# IMPORTANT SAFETY INSTRUCTIONS

All operators must read, understand and practice the following safety instructions. They will be repeated occasionally throughout this manual, and additional cautions may be added for specific causes.

## INTRODUCTION

These Operating Instructions pertain to the operation of the PAS28R Ride-On Automatic Scrubber.

If you have any questions about the operation, maintenance or use of the PAS28R please contact the technical service department.

The Operating Instructions must be read and observed by anyone using or operating the PAS28R.

All Operating Instructions must be followed to maintain the machine according to warranty guidelines. Adhere to all safety instructions carefully.

## SAFETY INFORMATION

The PAS28R is designed and built in accordance with standard safety regulations. However, physical danger to the operator or third parties or the impairment of the machine, or other objects

may arise during operation.

Always use the PAS28R in a perfect operating condition and in accordance with general rules of operational and personal safety, and always observe these Operating Instructions!

Eliminate malfunctions that may impair operational safety immediately!

Ensure that the Operating Instructions manual is always available and is legible. Replace any torn or missing pages.

In addition to the Operating Instructions, observe the generally applicable legal or other binding guidelines for accident prevention and environmental protection!

Do not leave any objects of any kind on the floor as they may be thrown at high speed by the brushes.

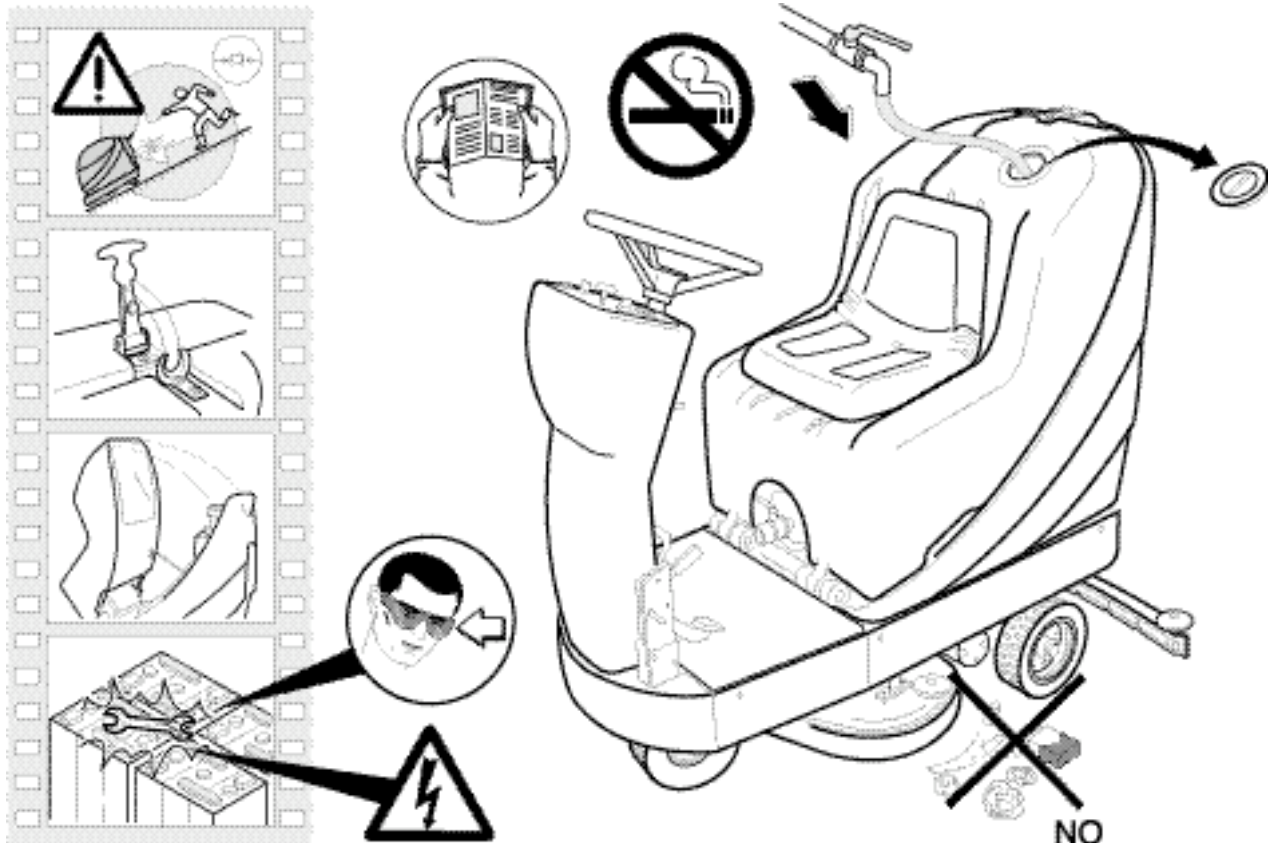

Keep feet and hands clear of the moving brushes.

Ensure that the main power key switch is in the OFF position and that the batteries are disconnected before carrying out any maintenance and/or filling the tanks with detergent and/or changing the brushes.

Do not modify or reconstruct the PAS28R in any way.

If the cleaner is left unattended, remove the key from the main power switch.

Do not leave the cleaner unattended particularly if children or unauthorized personnel are present.

Do not use or install the cleaner in places where inflammable gasses or liquids are present.

Do not use inflammable liquids or chemicals with this cleaner.

This machine must only be used on flat and level surfaces.

Take great care not to drag or overturn objects or shelves with the protruding parts of the machine, in particular the floor squeegee.

Always use manufacturer's original replacement parts.

Perform all prescribed maintenance as stated in the Operating Instructions.

Be sure to dispose of materials as well as replacement parts in a safe and environmentally acceptable way.

Prevent use by unauthorized persons by removing the ignition key after use.

When working near the batteries, use protective glasses and clothing. Remove any metal objects.

Do not rest metal tools or equipment of any type on batteries.

Recharging the batteries produces exposure gas. DO NOT smoke, light flames or make sparks.

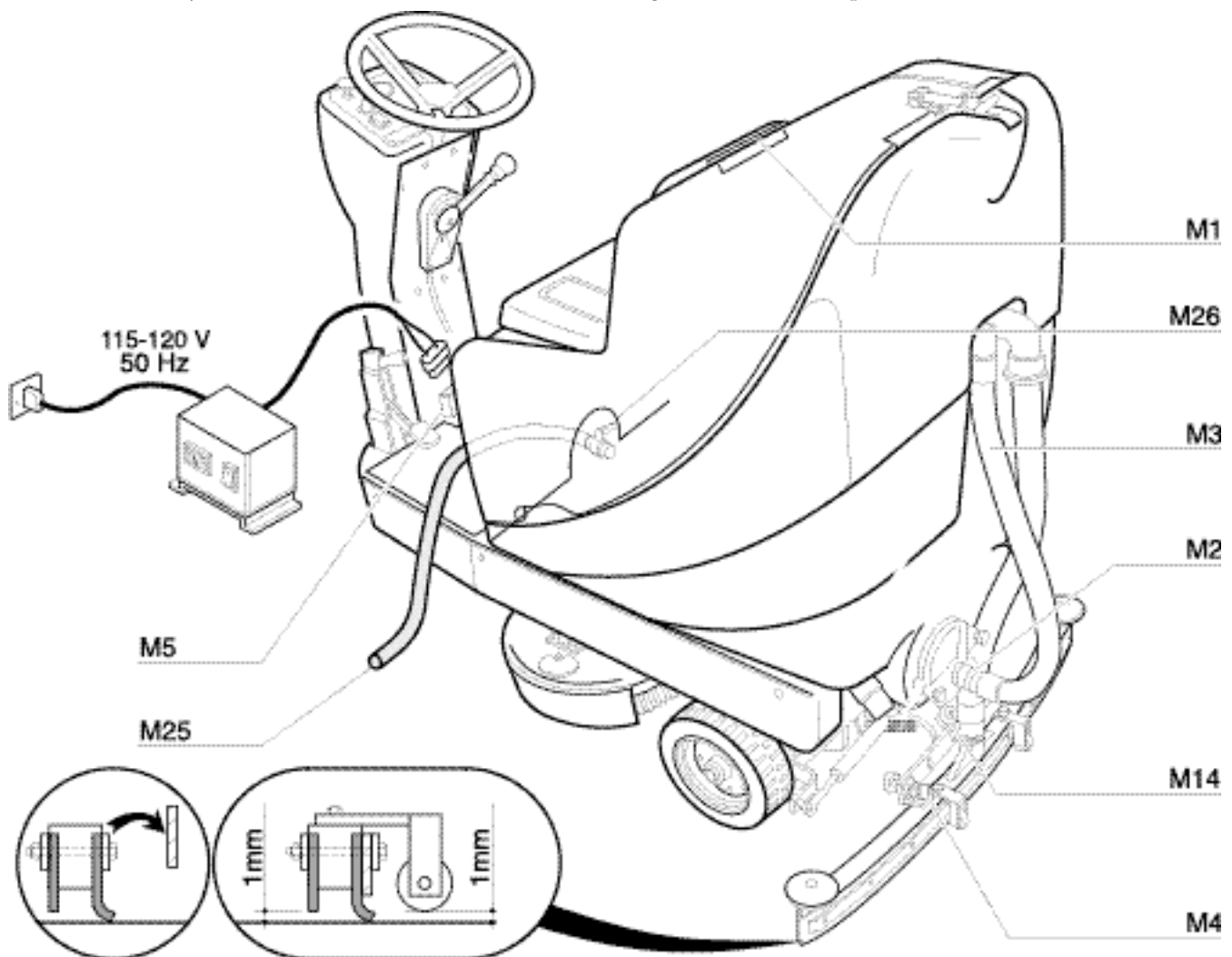

Ensure that the charger is switched off before disconnecting it from the batteries.

Recharge the batteries in a well ventilated area and with the cover fixed in the open position.

Do not draw current from the batteries with make-shift connectors, clips or contacts.

Park the cleaner on a flat and level floor and engage the parking brake.

The PAS28R will not function without an operator sitting on the seat.

Do not wet electrical components with water or any other liquid.

The PAS28R generates a sound pressure level in a warehouse environment of less than 80 dB. However, in other surroundings, this level may be exceeded. The customer must provide appropriate protection as well as notices to promote their use and periodic hearing examinations.

The operator must not wear clothing with sleeves, laces or belts; he must not approach the machine with bare or wet feet.

Do not operate the machine in bare feet, with sandals or any kind of open footwear,

### **CORRECT APPLICATION**

The PAS28R is designed exclusively for commercial applications of scrubbing, cleaning and washing level floors.

Any other use or application of this equipment is incorrect. The manufacturer does not accept responsibility for any damage caused to persons or to property, or the machine itself, if it is not used in the way described here or if the safety and maintenance instructions are not followed.

All operators must read and adhere to operating instructions and safety issues in this manual. All operators must have specific professional training or experience in using machines of this type.

## **SET-UP**

Before attempting to adjust or prepare the machine or to fill the tanks, make sure that the power supply is disconnected.

### **DETERGENT TANK**

The detergent tank is easily accessible from both sides of the machine. It can be filled from either side through the plug M1. In order to completely drain the detergent tanks, connect the hose M23 to the drainage tap M24.

Before filling the tank with the correct amount of diluted detergent, empty the waste collection tank as described under the heading Waste Tank.

The capacity of the detergent tank is 20 gallons. Only use the quantities and dilution ratios recommended by the detergent supplier and use only non-foaming detergents.

### **Operators should become familiar with all components of the PAS28R.**

M1	Detergent intake plug
M2	Dirty water rapid drainage
M3	Dirty water rapid pipe
M4	Floor wiper adjustment knobs
M5	Battery charger connector
M6	EMERGENCY button
M7	Start-up key switch
M8	Speed regulator, from 1 to 10
M9	Battery charge gauge
M10	Brush START regulator, from 1 to 10
M11	Aspirator start switch
M12	FORWARD/REVERSE control switch
M13	Horn
M14	Seat position adjustment lever
M15	Floor-wiper level
M16	Steering wheel
M17	Detergent supply tap
M18	Brake and parking brake
M19	Parking brake locking lever
M20	Accelerator
M21	Brush engagement spring
M22	Floor-wiper pressor knob
M23	Detergent rapid drainage pipe
M24	Detergent rapid drainage pipe
M25	Motor stop ring
M26	Exhaust gasket
M27	Detergent filter
M28	Brushes pilot light

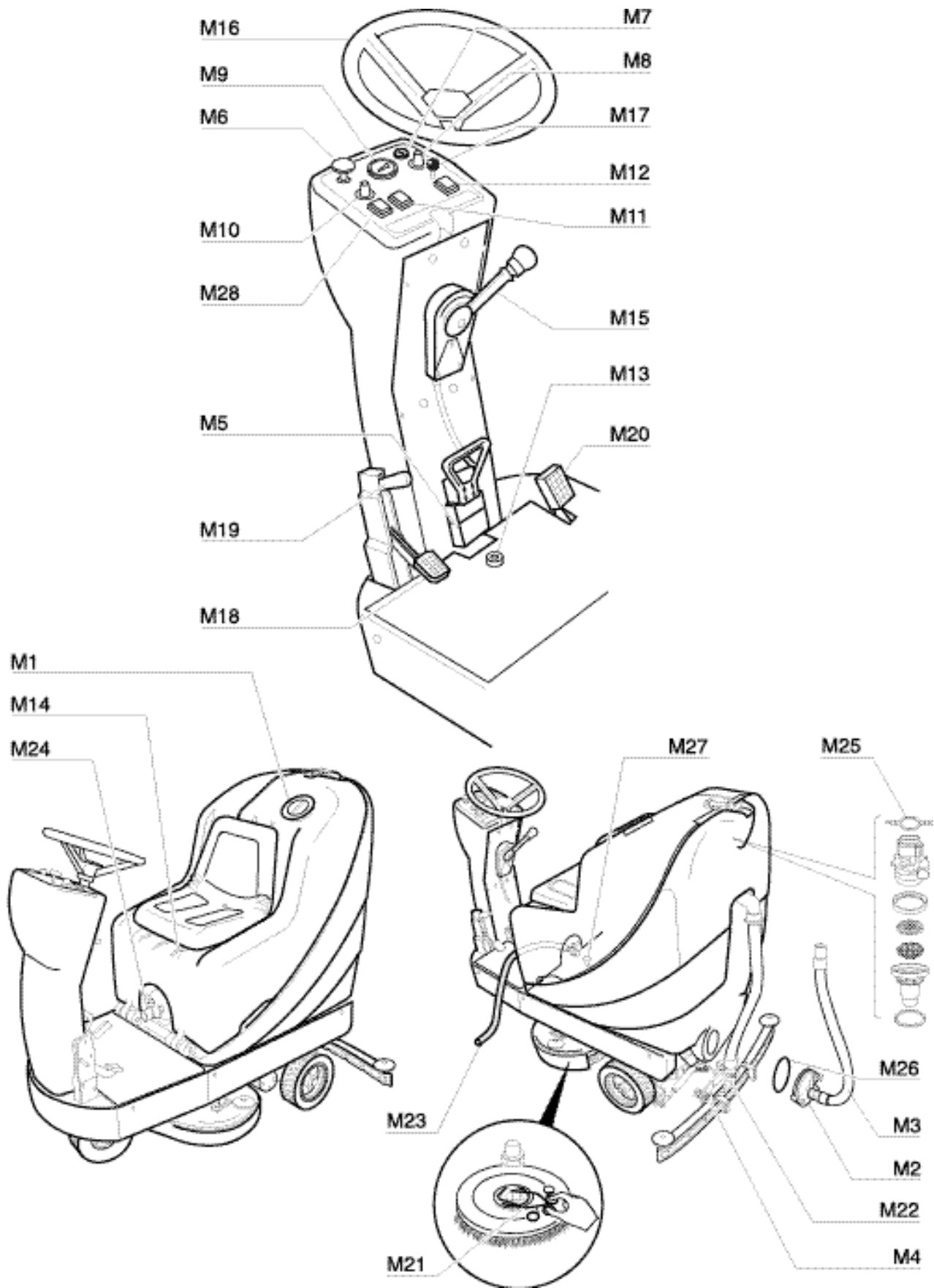

## WASTE TANK

The waste tank should be emptied after each use to prevent the dirt to settle.

1. Detach the hose M3 at the top
2. Open the rapid drainage plug and collect the dirty water and chemical residue in a container conforming to the environmental protection rules prescribed by the country of use.

## WIPER BLADE

The wiper blade finishes the drying operation. It is very important that it be in the correct position. When cleaning shiny or smooth floors and when there are joins between tiles it is recommended to not use the rear (lowest) rubber wiper.

1. Level the wiper using the knob M4 so that the black rubber strip approximately 1mm from the floor.

## Installing and Recharging the Batteries:

**WARNING:** The battery acid may give off harmful fumes.

When working near the batteries use protective glasses and clothes.

**WARNING:** DO NOT place any metal tools of any kind on the batteries.

**WARNING:** Make sure the battery charger is turned off before disconnecting. Recharge the batteries in a well ventilated area and keep the cover open.

The batteries are located in the battery compartment under the cover.

1. Apply a coating of grease (Vaseline) to the battery terminals.
2. Connect the batteries as shown on page 13.
3. Make sure the terminals are securely tightened.
4. Use the cable supplied to connect to the mains supply.
5. Make sure the supply voltage is the same as indicated on the battery charger itself.
6. To charge the batteries connect the connector M5, which comes directly from the battery compartment, to the battery charger connector.
7. The charger will automatically regulate the charging current and will turn itself off when the batteries are recharged.

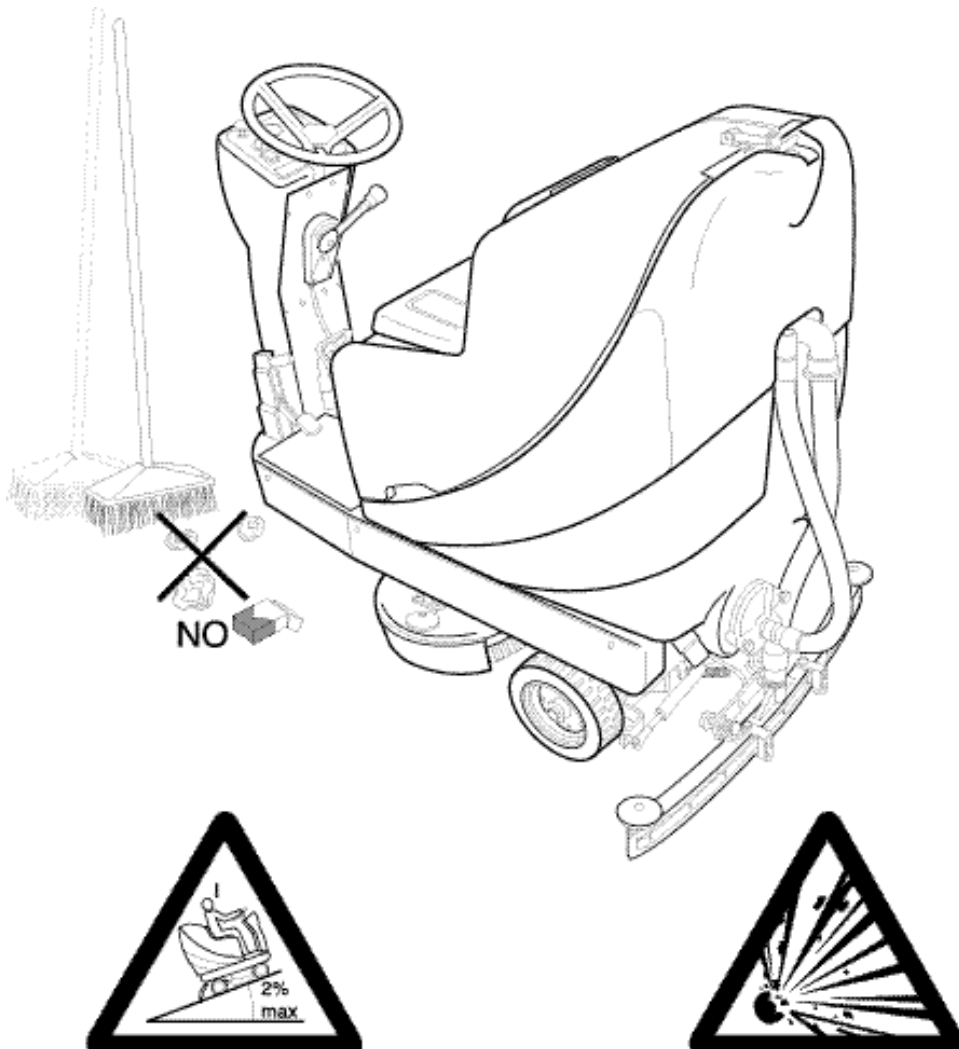

## USING THE PAS28R

Loose debris and substantial dirt should be cleared from the area to be scrubbed with a sweeper or broom prior to using the auto scrubber. This will prevent the scrubber intake circuit from immediately choking and allow the detergent to work effectively.

Certain floors or environments require particular attention or even a second pass with the cleaner. In this case, you should make a pass with the wiper raised and the brush in the working position. The detergent will have additional dwell time and provide additional cleaning power. The second pass should be made with the brush and wiper lowered and at a slower speed.

1. Switch off the battery charger and disconnect it from the machine.
2. Adjust the seat position to suit individual requirements. The machine will not turn on until an operator is seated.
3. Select the direction with the switch M12 and grip the steering wheel M16.
4. Insert the key switch M7 to enable the electrical circuits.
5. Lower squeegee blades M15

6. Engage brush rotation with the regulator M10 and the aspirators with the switch M11.
7. Gradually open the detergent supply tap M17 according to the operation speed.
8. Engage FORWARD or REVERSE gear with the lever M12 and gradually depress the accelerator pedal M20. When REVERSE gear is engaged a BEEP signal is emitted.
9. With the accelerator pedal fully pressed the regular M8 can be adjusted so as to achieve a constant speed, avoiding the formation of rings on the floor.
10. Adjust the brush pressure with the regulator M10.
11. The instrument M9 allows the battery charge level to be read.
12. When necessary or to warn of danger use the horn M13.
13. To stop the machine gradually press the brake pedal M18.
14. Always engage the parking brake by pressing the pedal M18 and actuating the lever M19.
15. Remove the key M7.

**WARNING:** In the case of problems or short-circuits press the EMERGENCY button M6 and contact the service center.

**WARNING:** When the machine is abandoned it switches off automatically.

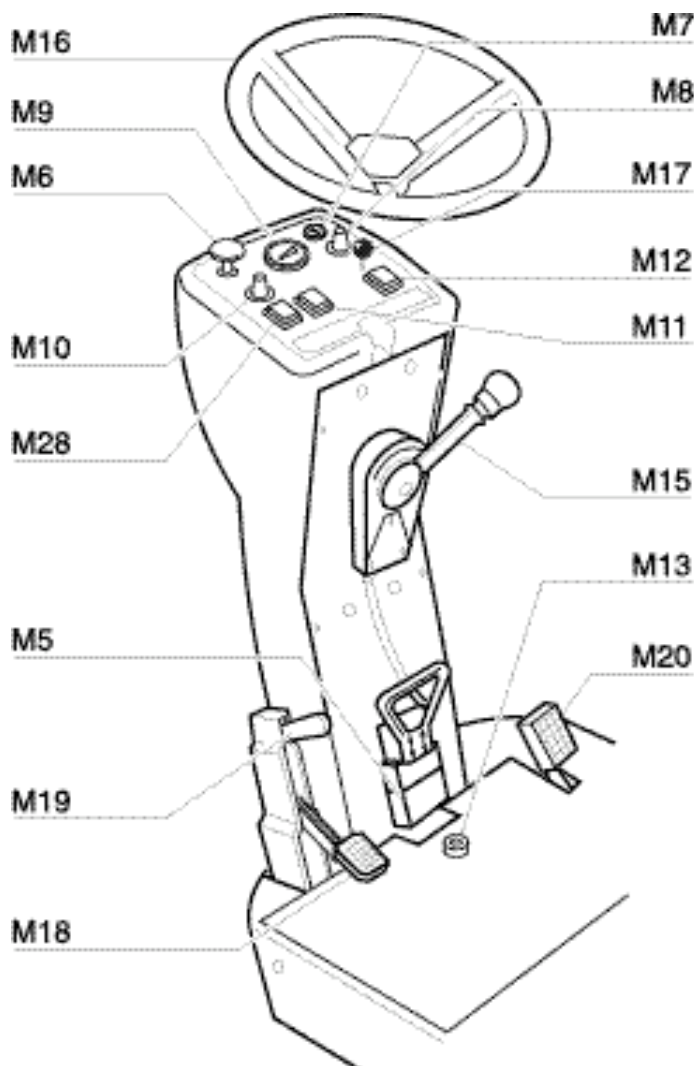

## MAINTENANCE

### DETERGENT TANK:

Drain the tank after each use.

1. Fit the tube M23 into the rapid drainage tap M24.
2. Open the tap.
3. Remove the flange M2 and clean the internal filter M27.
4. Rinse and clean the tank.

### BATTERIES.

Keep the batteries clean and dry with antistatic cloths.

**WARNING:** The battery acid may give off harmful fumes. When working near the batteries use protective glasses and clothes.

**WARNING:** DO NOT place any metal tools of any kind on the batteries.

**WARNING:** Make sure the battery charger is turned off before disconnecting. Recharge the batteries with the cell plugs removed in a well ventilated area and keep the cover open.

### FLOOR WIPER

1. Inspect and clean the floor wiper after each use and make sure to restore it to its working condition.
2. If the drying action is not perfect after cleaning the wiper assembly, remove and replace any worn rubber blades.

### BRUSH

Inspect brush to ensure it is in working order.

1. To remove a worn brush:
2. Lift brushes with the regulator M10 and switch off the machine.
3. Remove the key M7 from the control panel.
4. Turn the brush, to be removed, by hand until the coils of spring M21 are accessible.
5. By closing together the coils of spring M21 with your fingers (as if you were closing a pair of scissors) the brush will free itself.

### WASTE TANK

Clean the waste tank after each use.

1. Shut off the machine.
2. Remove the M25 motor lock ring and lift off the suction motor from its seat.
3. Carefully clean the filter, net and sponge, and remove the direct accumulated in the tank by water jetting.
4. To ease the operations, detach the discharge assembly M2 by unscrewing the lateral knobs.
5. Carefully clean the housing of the bi-angular bearing M26.
6. Reassemble.

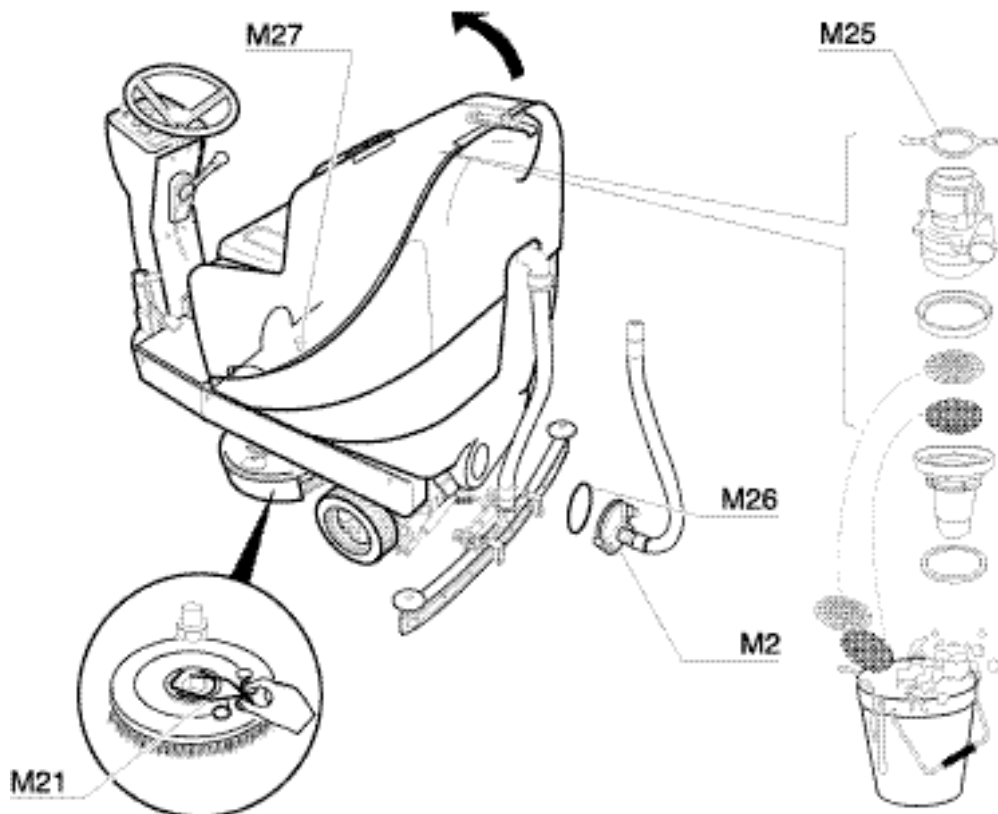

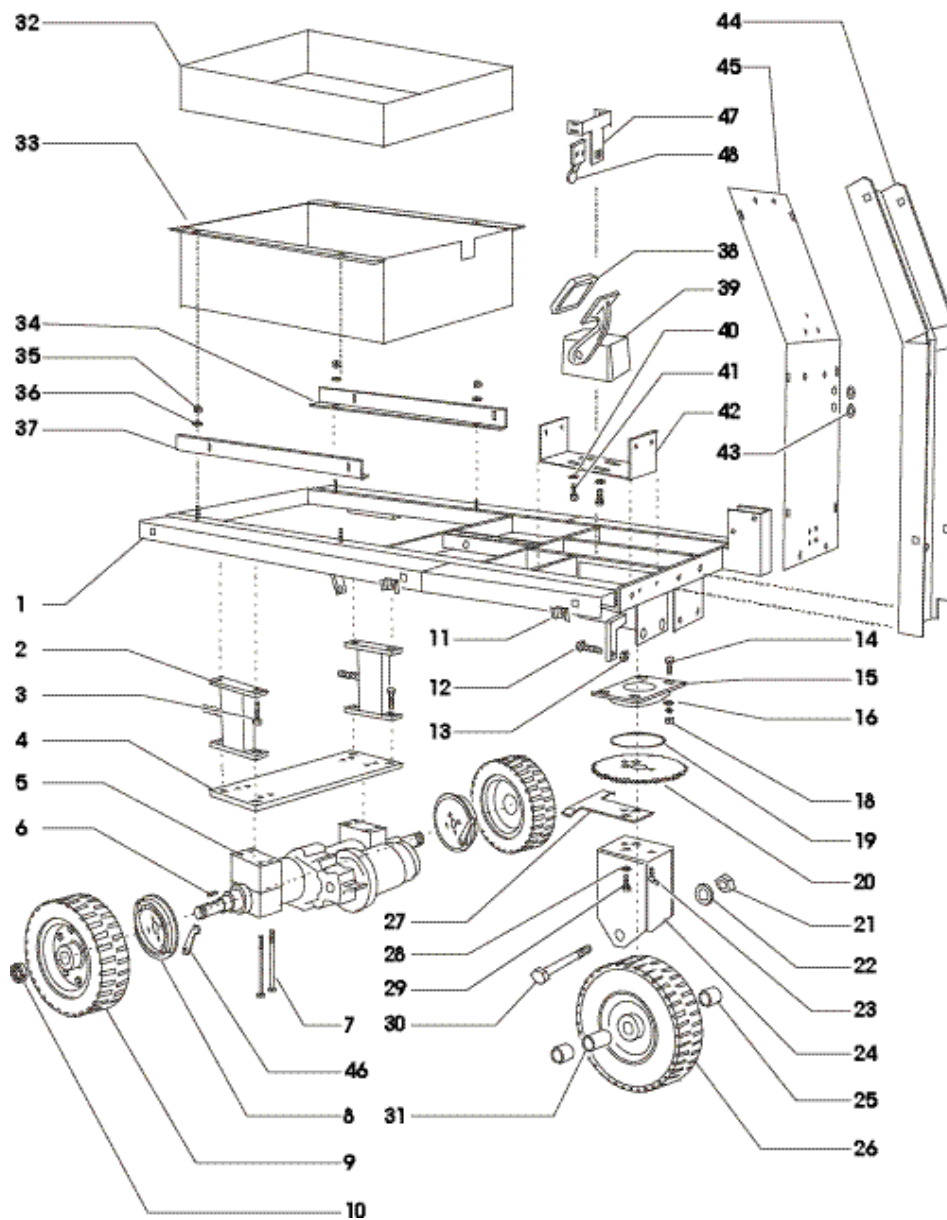

<b>ref#</b>	<b>order</b>	<b>description</b>
1	<b>710.001</b>	Frame
2	<b>710.002</b>	Support
3	<b>PAS190</b>	Screw
4	<b>710.004</b>	Plate
5	<b>710.005</b>	Reducer motor
6	<b>710.006</b>	Tang
7	<b>710.007</b>	Screw
8	<b>1000.027</b>	Brake
9	<b>710.009</b>	Wheel
10	<b>710.010</b>	Ring nut
11	<b>430.063</b>	Cage nut
12	<b>PAS223</b>	Screw
13	<b>PAS937</b>	Nut
14	<b>PAS190</b>	Screw
15	<b>710.015</b>	Nut
16	<b>PAS137</b>	Washer
18	<b>PAS937</b>	Nut
19	<b>710.019</b>	Seal
20	<b>710.020</b>	Crown wheel
21	<b>710.021</b>	Nut

<b>ref#</b>	<b>order</b>	<b>description</b>
22	<b>710.022</b>	Washer
23	<b>710.023</b>	Greaser
24	<b>710.024</b>	Support
25	<b>710.025</b>	Spacer
26	<b>710.026</b>	Wheel
27	<b>710.027</b>	Plate
28	<b>710.028</b>	Washer
29	<b>710.029</b>	Screw
30	<b>710.030</b>	Screw
31	<b>710.031</b>	Spacer
32	<b>710.032</b>	Vat pe
33	<b>710.033</b>	Vat
34	<b>710.034</b>	Stop strip
35	<b>PAS176</b>	Nut
36	<b>PAS188</b>	Washer
38	<b>PAS14</b>	Rubber
39	<b>PAS451</b>	Accelerator
40	<b>710.040</b>	Washer
41	<b>710.041</b>	Screw
42	<b>1000.063</b>	Support

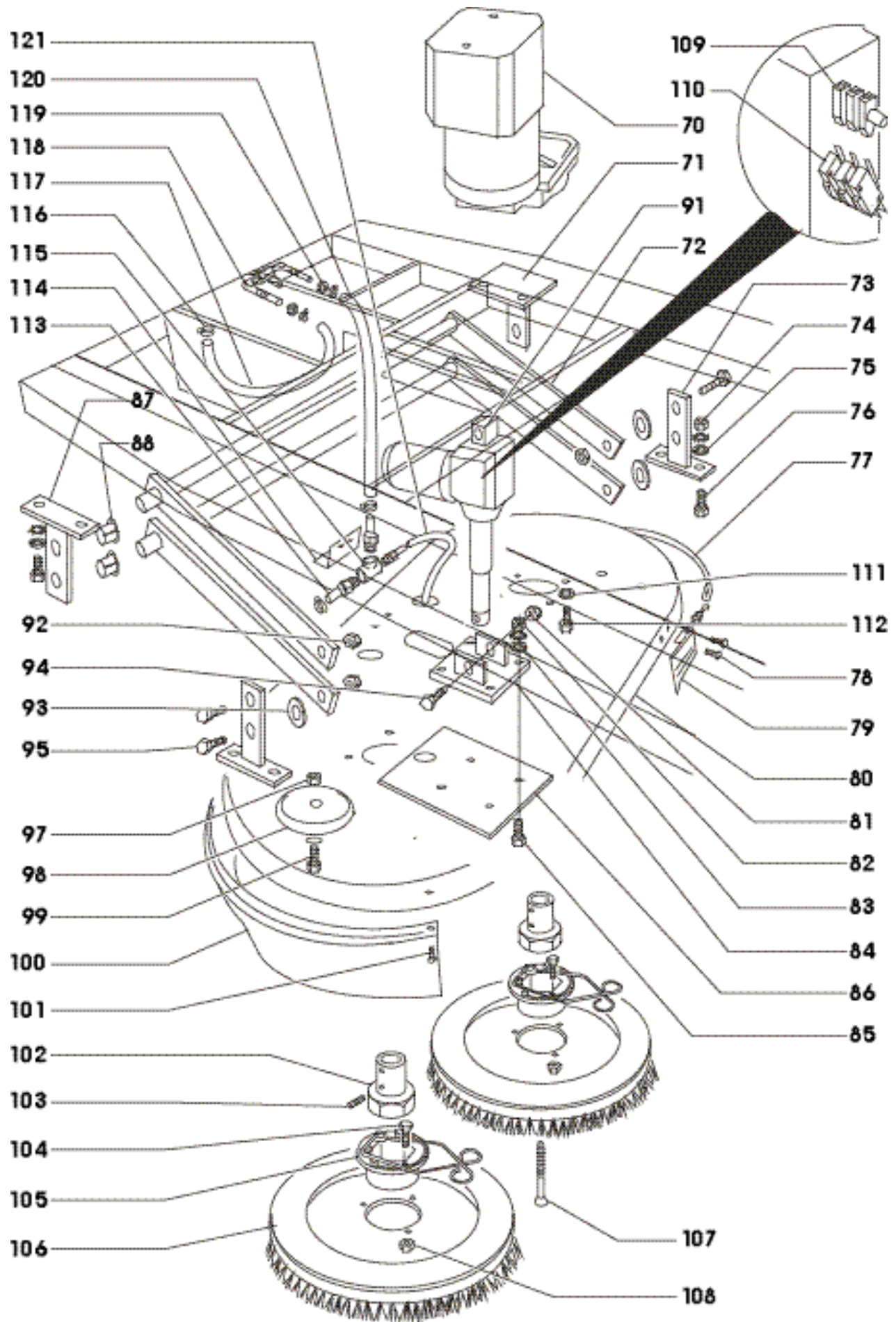

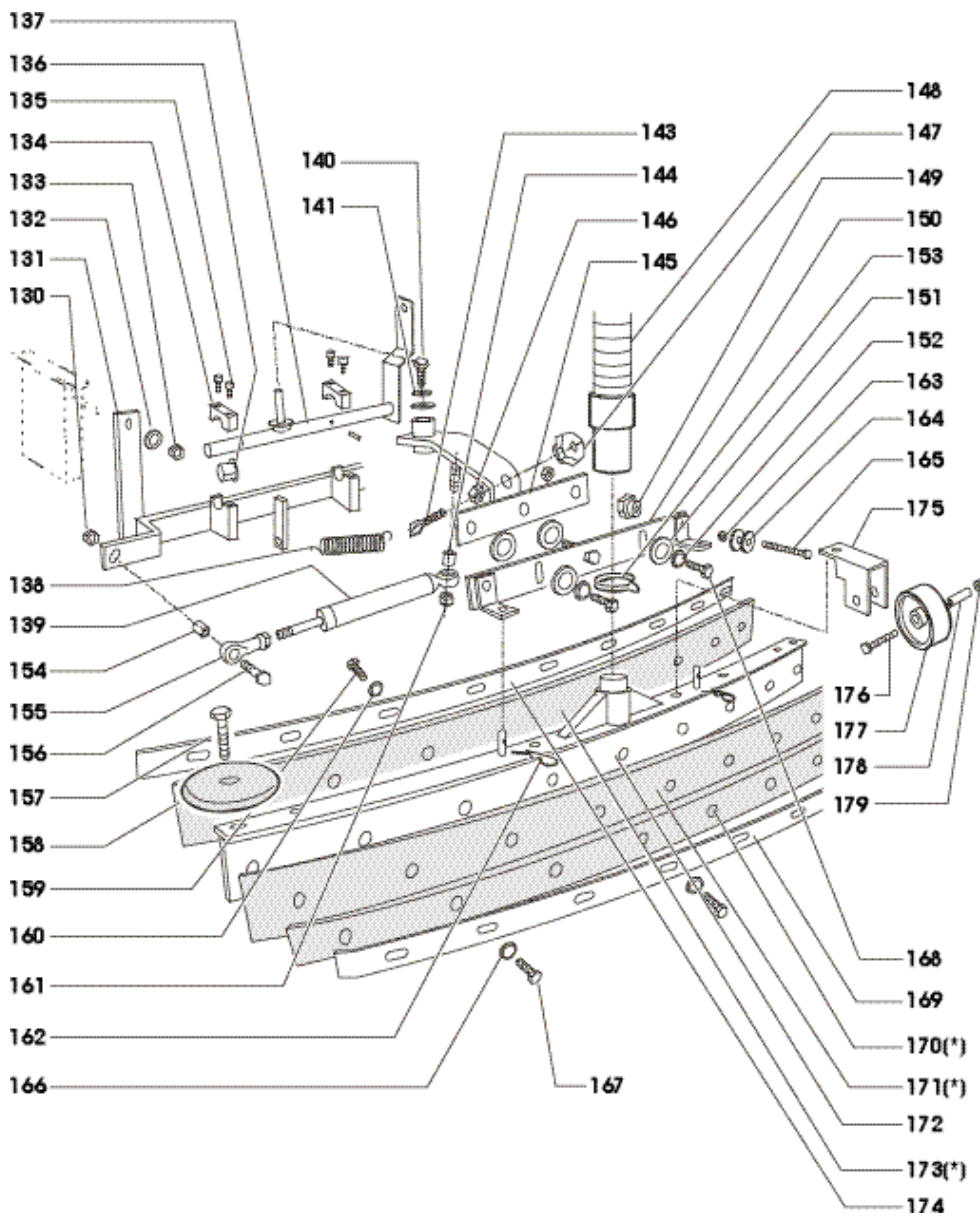

<i>ref#</i>	<i>order</i>	<i>description</i>
43	<b>710.043</b>	Rubber
44	<b>710.044</b>	Support
45	<b>710.045</b>	Plate
46	<b>1000.020</b>	Lever
47	<b>710.047</b>	Support
48	<b>PAS416</b>	Limit switch
70	<b>PAS4</b>	Geared motor
71	<b>710.071</b>	Support
72	<b>710.072</b>	Lever
73	<b>710.073</b>	Support
74	<b>500.200</b>	Nut
75	<b>PAS137</b>	Washer
76	<b>PAS190</b>	Screw
77	<b>PAS108</b>	Splash guard strip
78	<b>501.047</b>	Screw
79	<b>PAS122</b>	Hook
80	<b>710.080</b>	Plate
81	<b>1000.131</b>	Nut
82	<b>PAS176</b>	Nut
83	<b>PAS188</b>	Washer
84	<b>710.084</b>	Plate

<i>ref#</i>	<i>order</i>	<i>description</i>
85	<b>PAS936</b>	Screw
86	<b>710.086</b>	Plate
87	<b>710.087</b>	Support
88	<b>710.088</b>	Bushing
91	<b>710.091</b>	Actuator
92	<b>500.200</b>	Nut
93	<b>710.093</b>	Nylon washer
94	<b>1000.129</b>	Screw
95	<b>PAS190</b>	Screw
97	<b>PAS924</b>	Nut
98	<b>PAS1</b>	Buffer wheel
99	<b>PAS223</b>	Screw
100	<b>430.018</b>	Splash guard
101	<b>PAS926</b>	Screw
102	<b>PAS5</b>	Coupling
103	<b>430.073</b>	Dowel
104	<b>PAS123</b>	Screw
105	<b>PAS6A</b>	Support with spring
106	<b>PAS67</b>	Poly Scrub brush (2)
106	<b>PAS68</b>	Nylo Grit II brush (2)
106	<b>PAS130</b>	Strata Grit II brush (2)

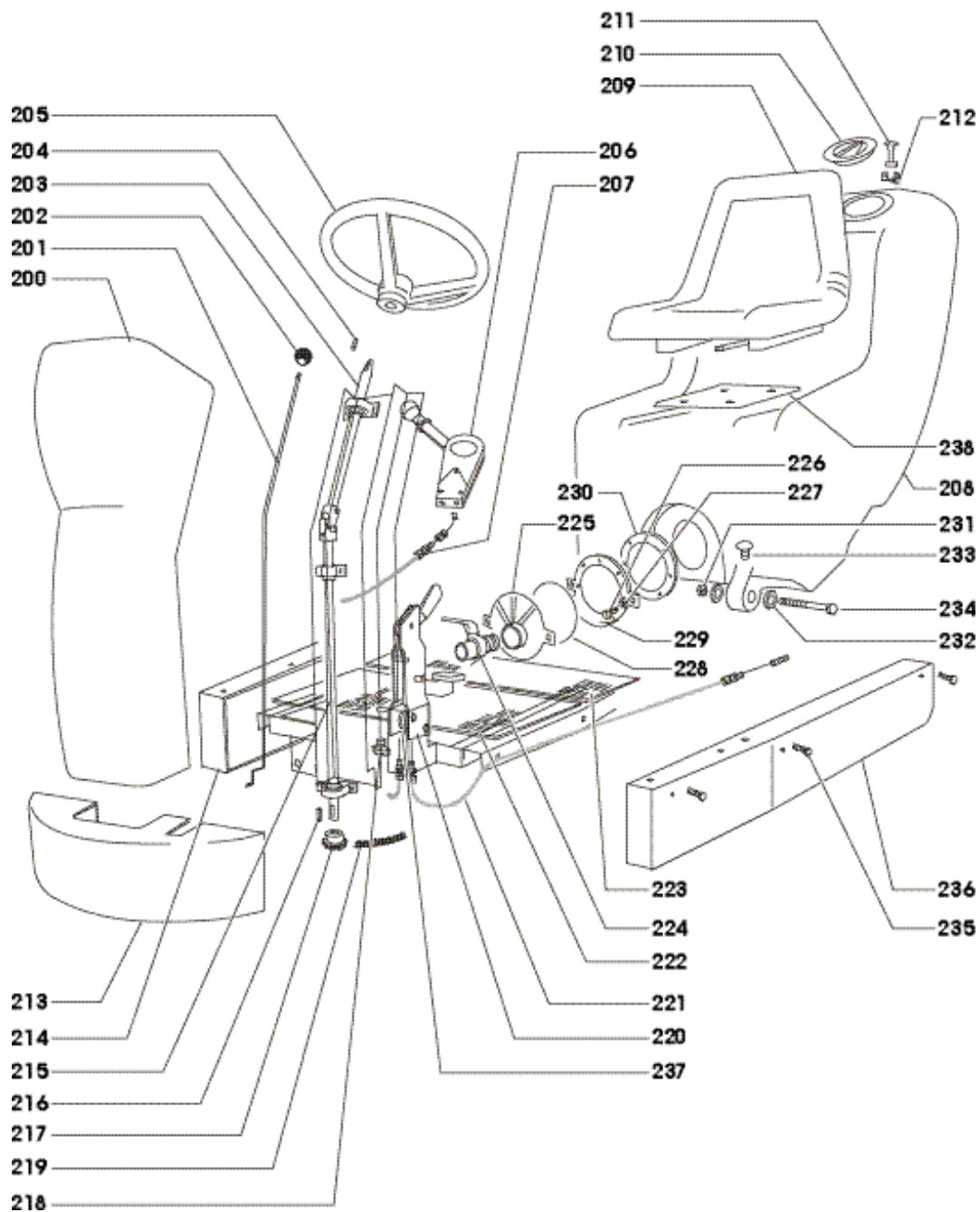

<i>ref#</i>	<i>order</i>	<i>description</i>
106	<b>PAS94</b>	Scrub Grit II brush (2)
106	<b>PAS69</b>	Pad driver (2)
106	<b>PAS133</b>	Powr Scuff brush (2)
107	<b>PAS111</b>	Screw
108	<b>PAS149</b>	Nut
109	<b>PAS426</b>	Cam
110	<b>PAS427</b>	Micro
111	<b>PAS146</b>	Washer
112	<b>430.072</b>	Screw
113	<b>710.113</b>	Hose fitting
114	<b>710.114</b>	Support
115	<b>400.160.1</b>	Water tap
116	<b>1000.187</b>	Hose collors
117	<b>710.117</b>	Rubber tube
118	<b>PAS12</b>	Water tap
119	<b>PAS262</b>	Nut

<i>ref#</i>	<i>order</i>	<i>description</i>
120	<b>710.120</b>	Rubber tube
121	<b>710.121</b>	Rubber tube
130	<b>PAS937</b>	Nut
131	<b>710.131</b>	Support
132	<b>710.028</b>	Washer
133	<b>850.058</b>	Nut
134	<b>710.134</b>	Support
135	<b>710.135</b>	Screw
136	<b>710.088</b>	Bushing
137	<b>710.137</b>	Lever
138	<b>PAS31</b>	Spring
139	<b>PAS421</b>	Piston
140	<b>710.041</b>	Screw
141	<b>PAS188</b>	Washer
143	<b>PAS63</b>	Pin
144	<b>710.144</b>	Spacer

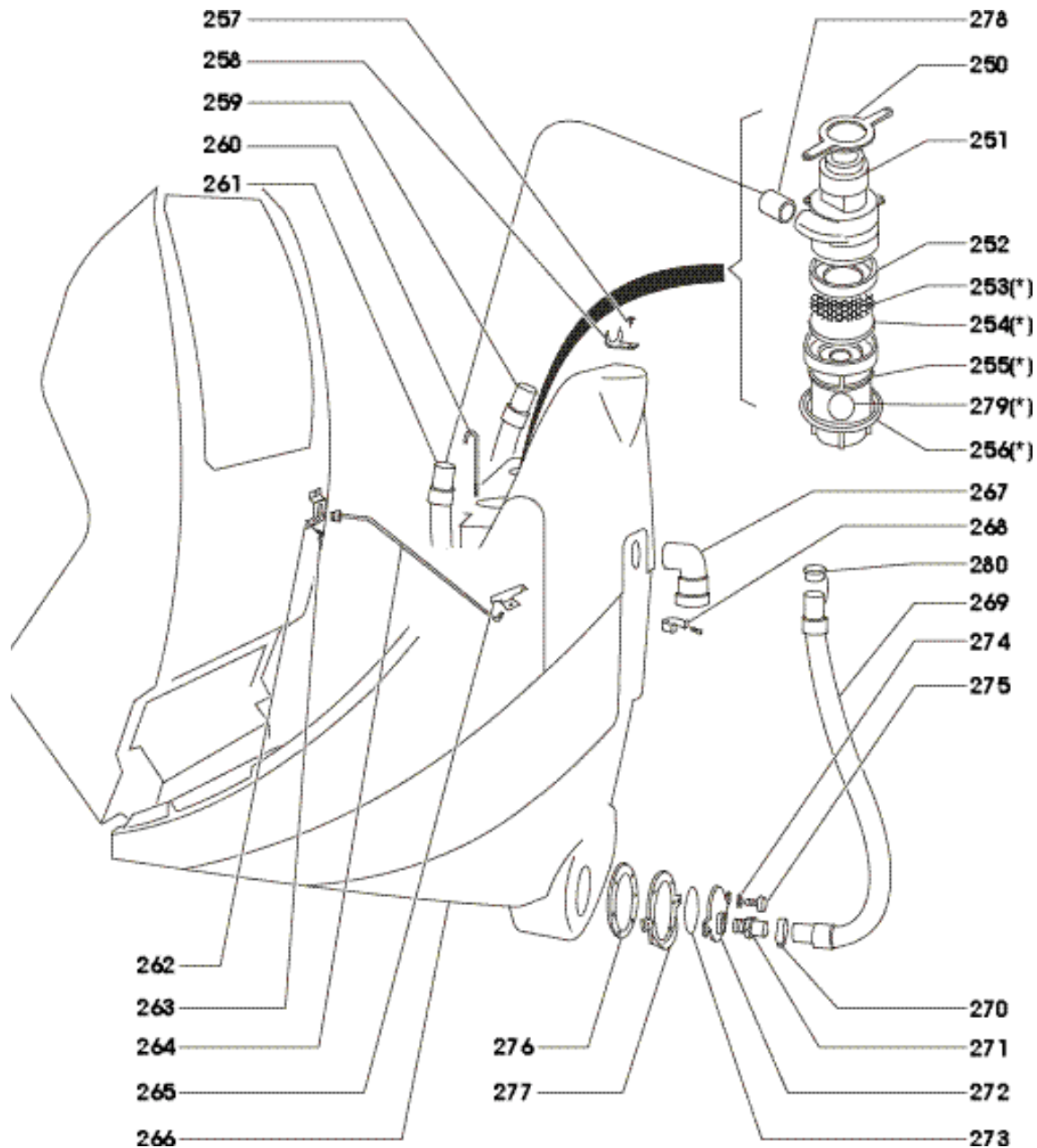

<i>ref#</i>	<i>order</i>	<i>description</i>
145	<b>710.145</b>	Lever
146	<b>PAS176</b>	Nut
147	<b>PAS64</b>	Knob
148	<b>710.148</b>	Pipe
149	<b>500.223.1</b>	Knob
150	<b>PAS214</b>	Support
151	<b>PAS212</b>	Nylon washer
152	<b>710.040</b>	Washer
153	<b>PAS191</b>	Hose collors
154	<b>710.154</b>	Spacer
155	<b>PAS422</b>	Stop
156	<b>PAS223</b>	Screw
157	<b>860.061</b>	Screw
158	<b>PAS1</b>	Buffer wheel
159	<b>PAS223</b>	Screw
160	<b>710.160</b>	Washer

<i>ref#</i>	<i>order</i>	<i>description</i>
161	<b>PAS924</b>	Nut
162	<b>PAS959</b>	Split pin
163	<b>PAS176</b>	Nut
164	<b>500.222.1</b>	Regulator
165	<b>710.165</b>	Screw
166	<b>710.166</b>	Washer
167	<b>PAS223</b>	Screw
168	<b>710.168</b>	Screw
169	<b>PAS261</b>	Back strip
170	<b>PAS144</b>	Crepe rubber
171	<b>PAS143</b>	Crepe rubber
172	<b>PAS77</b>	Floor washing body
173	<b>PAS145</b>	Black rubber
174	<b>650.178</b>	Front streep
175	<b>710.175</b>	Support
176	<b>710.176</b>	Screw

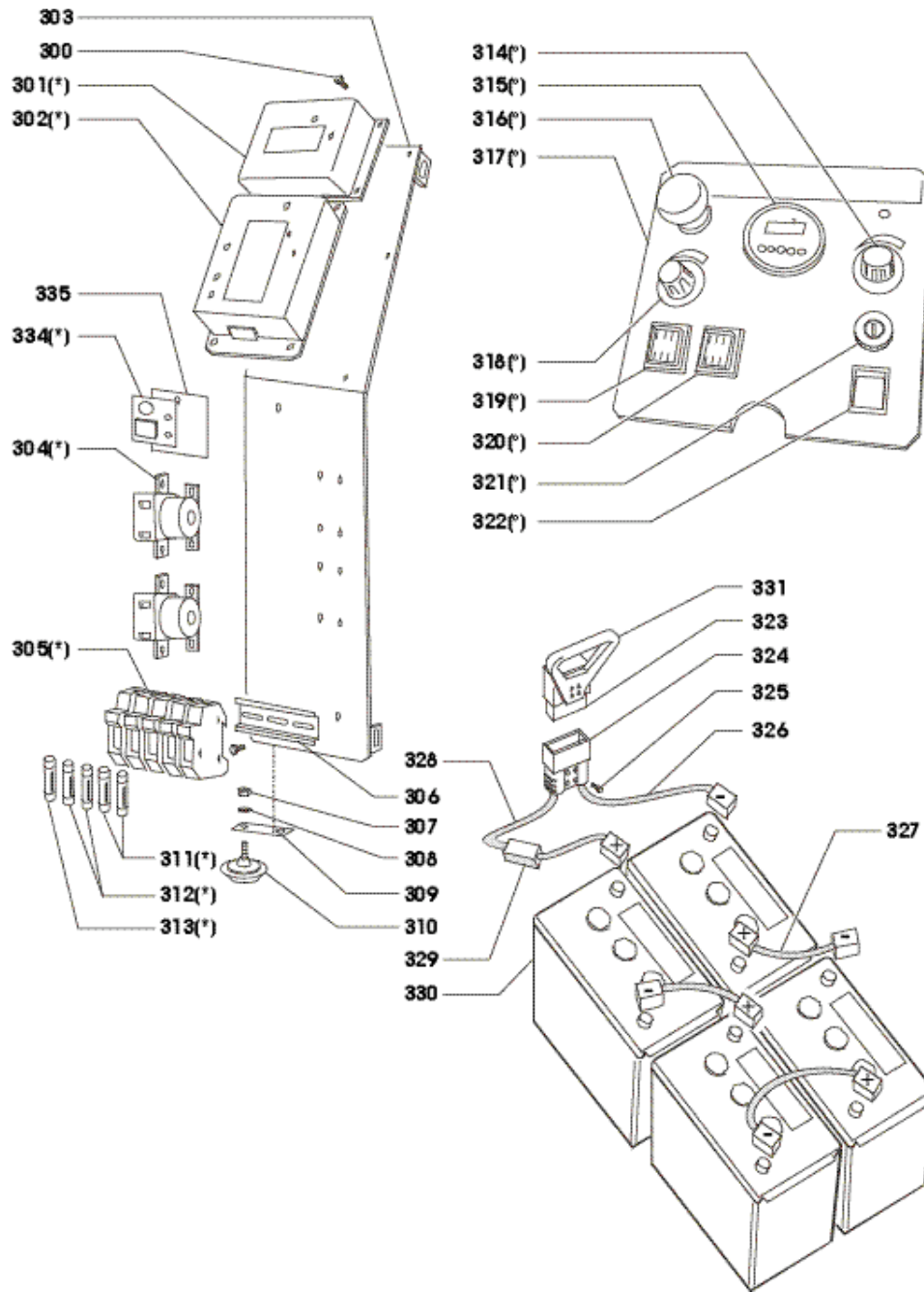

<i>ref#</i>	<i>order</i>	<i>description</i>
177	<b>710.177</b>	Wheel
178	<b>710.178</b>	Spacer
179	<b>430.311</b>	N/A
(*)	<b>PAS76</b>	Rubber kit
200	<b>710.200</b>	Chest
201	<b>710.201</b>	Rod
202	<b>PAS11</b>	Knob
203	<b>1000.072</b>	Shaft
204	<b>1000.069</b>	Tang
205	<b>1000.068</b>	Steering wheel
206	<b>710.206</b>	Lever
207	<b>710.207</b>	Complete cable
208	<b>710.208</b>	Tank
209	<b>1000.196</b>	Seat
210	<b>1000.194</b>	Plug

<i>ref#</i>	<i>order</i>	<i>description</i>
211	<b>710.211</b>	Hook
212	<b>710.212</b>	Support
213	<b>710.213</b>	Shield
214	<b>710.214</b>	Casing
215	<b>710.215</b>	Shaft
216	<b>1000.110</b>	Tang
217	<b>710.217</b>	Pinion
218	<b>710.218</b>	Horn
219	<b>710.219</b>	Chain
220	<b>PAS410</b>	Support
221	<b>710.221</b>	Complete cable
222	<b>710.222</b>	Floor plate 1
223	<b>710.223</b>	Floor plate 1
224	<b>PAS75</b>	Solution valve
225	<b>500.089.1</b>	Movable flange

<i>ref#</i>	<i>order</i>	<i>description</i>
226	<b>PAS74</b>	Knob
227	<b>PAS186</b>	Washer
228	<b>PAS441</b>	Seal
229	<b>PAS440</b>	Fixed flange
230	<b>PAS70</b>	Seal
231	<b>1000.184</b>	Nut
232	<b>1000.183</b>	Washer
233	<b>PAS3</b>	Filter
234	<b>710.234</b>	Screw
235	<b>710.235</b>	Screw
236	<b>710.236</b>	Casing
237	<b>710.237</b>	Sheave
238	<b>1000.196.2</b>	Plate
250	<b>PAS15</b>	Lock ring
251	<b>1924</b>	Suction motor
252	<b>PAS103</b>	Seal
253	<b>PAS79</b>	Net
254	<b>PAS107</b>	Sponge
255	<b>PAS85</b>	Support
256	<b>PAS103</b>	Seal
257	<b>PAS243</b>	Screw
258	<b>710.258</b>	Support
259	<b>710.259</b>	Pipe
260	<b>401.105</b>	Tie rod
261	<b>710.261</b>	Pipe
262	<b>510.118</b>	Plate
263	<b>710.263</b>	Screw
264	<b>510.264</b>	Rod
265	<b>510.116</b>	Plate
266	<b>710.266</b>	Tank
267	<b>1000.279</b>	Curve
268	<b>PAS38</b>	Pipe strap
269	<b>710.269</b>	Pipe
270	<b>710.270</b>	Hose collors
271	<b>500.089.1</b>	Hose fitting
272	<b>PAS442</b>	Movable flange
273	<b>PAS441</b>	Seal
274	<b>PAS186</b>	Washer
275	<b>PAS74</b>	Knob
276	<b>PAS70</b>	Seal
277	<b>PAS440</b>	Fixed flange

<i>ref#</i>	<i>order</i>	<i>description</i>
278	<b>PAS330</b>	Sleeve
279	<b>PAS210</b>	Float level
280	<b>PAS36</b>	Plug
(*)	<b>PAS17</b>	Complete float level
300	<b>1000.293</b>	Screw
301	<b>710.301</b>	Jack card
302	<b>710.302</b>	Traction card
303	<b>710.303</b>	Plate
304	<b>PAS57</b>	Remote control
305	<b>860.230</b>	Fuse holder
306	<b>1000.288</b>	Slide
307	<b>1000.301</b>	Nut
308	<b>1000.302</b>	Washer
309	<b>710.309</b>	Square
310	<b>1000.304</b>	Horn
311	<b>PAS118</b>	Fuse
312	<b>PAS118</b>	Fuse
313	<b>1000.344</b>	Fuse
314	<b>PAS450</b>	Potentiometer
315	<b>710.315</b>	Battry charge level
316	<b>710.316</b>	Pushbutton
317	<b>710.317</b>	Electric panel
318	<b>PAS55</b>	Potentiometer
319	<b>PAS454</b>	Pilot light
320	<b>PAS54</b>	Switch
321	<b>PAS53NS</b>	Key switch
322	<b>710.322</b>	Switch
323	<b>710.323</b>	Fastener
324	<b>710.324</b>	Pin
325	<b>1000.300</b>	Screw
326	<b>710.326</b>	Cable
327	<b>1000.338</b>	Cable
328	<b>710.328</b>	Cable
329	<b>710.329</b>	Fuse
330	<b>710.330</b>	Hose battery425 ah
331	<b>PAS446</b>	Handle
334	<b>710.334</b>	Diode card
335	<b>710.333</b>	Plate
(*)	<b>710.332</b>	Electric plant
(°)	<b>710.333</b>	Panel plant



A Tacony Company  
3101 Wichita Court • Ft. Worth, TX 76140-1710