



Predator Automatic Scrubber 28

OPERATORS MANUAL AND PARTS LIST

Model PAS28



Contains drawings for all PAS28 models to date

WARNING: OPERATOR MUST READ AND UNDERSTAND THIS MANUAL COMPLETELY BEFORE OPERATING THIS EQUIPMENT.

TECHNICAL CHARACTERISTICS

POWR-FLITE® PREDATOR™ 28 AUTO SCRUBBER MODEL PAS28

Technical Specifications	U.S. Standard	Metric
Area per hour	44,000 sq. feet	4088 sq. meters
Solution Tank	20 gallons	73 liters
Recovery Tank	20 gallons	73 liters
Cleaning Width (brush)	28 inches	700 mm
Squeegee Width	40½ inches	1030 mm
Brush Pressure	150 lbs.	68 kg.
Brush Speed	225 RPM	
Brushes	(2) 14 inches	(2) 356 mm
Brush Motor (power rating)	24 volts/400 watts	
Brush Motor (power rating)	2 1/2 HP motors	
Vacuum Motor (power rating)	24 volts/450 watts (Bypass)	
Driver Motor (power rating)	24 volts/200 watts (Electronically Controlled)	
Supply Voltage (battery)	24 volts	
Continuous Operating Run Time	.8 hrs.	
Operating Time	.8-10 hrs.	
Batteries	.6 volt, 244 amp max., 4 required	
Dimensions - Scrubber	60"L x 40"W x 40"H	1527mmL x 764mmW x 1016mmH
Weight w/o batteries	330 lbs.	150 kg.
Battery storage area	20¾"L x 16¼"W x 16¼"H	518mmL x 406mmW x 406mm H

IMPORTANT SAFETY INSTRUCTIONS

All operators must read, understand and practice the following safety instructions.

They will be repeated occasionally throughout this manual, and additional cautions may be added for specific causes.

- **CAUTION:** Operators must read and understand this manual completely before operating this equipment.
- **CAUTION:** Make sure key switch is in the "OFF" position before installing pad.
- **CAUTION:** Loose objects on the floor can become dangerous projectiles if struck by the high-speed pad. Remove them before operating this machine.
- **CAUTION:** Keep hands and feet away from revolving pad.
- **CAUTION:** Keep machine moving to prevent damage to finish or floor.
- **CAUTION:** Make sure key switch is turned "OFF" and battery connector is unplugged from machine before performing any maintenance procedures.
- **CAUTION:** Maintenance and repairs must be performed by authorized personnel.
- **CAUTION:** Battery acid can cause burns. When working on or around batteries, wear protective clothing and safety glasses. Remove metal jewelry. Do not lay tools or metal objects on top of batteries.
- **CAUTION:** Do not operate this equipment in bare feet or with open-toed shoes or sandals.
- **CAUTION:** Charging batteries generate explosive gases. ***NO SMOKING OR OPEN FLAMES OR SPARKS.*** Make sure the charger has turned off before disconnecting it from the batteries. Charge batteries in a well-ventilated area with the tanks in the raised and locked position.
- **CAUTION:** Store or park this machine on a level surface only. Remove key from switch if machine is left unattended.
- **CAUTION:** Do not operate machine or charger in areas where flammable liquids or gases are present. Do not use or pick up flammable chemicals or liquids with this machine.
- **CAUTION:** Make sure all caution, warning and instructional decals are in place and legible. Replace damaged or missing labels.
- **CAUTION:** These machines are designed for level floor operations only. ***DO NOT OPERATE ON RAMPS OR INCLINES*** unless adequate personnel are available for assistance.
- **CAUTION:** Do not expose electrical components to water or other liquids. To clean machine wipe down with a damp cloth.

POWR-FLITE PREDATOR 28 AUTOMATIC SCRUBBER

This manual refers to a battery powered automatic floor scrubber. Designed to be simple, easy to operate and safe, with maneuverability and automatic variable electronic drive. Routine maintenance has been simplified and reduced to the minimum to keep equipment on the job.

THE BASIC DESCRIPTION OF THE MACHINE CAN BE SUMMED UP BY THE FOLLOWING FEATURES:

1. Sealed ball-bearing wheels - maintenance free with polyurethane covered cast iron wheels.
2. Independent drive system, totally enclosed motor, direct drive, dual wheel drive for superior traction.
3. State of the art, soft start offers full range and variable drive powered by fully lubricated sealed forward and reverse drive motor.
4. Unprecedented quality & workmanship, simplified control panel.
5. From safety & theft-proof position, control panel equipped with key for "on/off" prevents unauthorized operation.
6. Hospital quiet, reduced noise level.
7. Bypass vacuum motor with tangential discharge.
8. High-speed brush drive with 150 lbs. of contouring pad pressure prevents streaking and produces high productivity with 2 independently operating geared motors.
9. Solution control conveniently located with ease of operation and dispensing control...user friendly...
10. Increased working capacity and productivity offered by higher brush drive speed, increased full contouring pad pressure and operation fatigue eliminating drive system.
11. 15% fewer working parts and components for trouble free operating and servicing machine.
12. 8 year warranty on housing and tanks
5 year warranty on frame
1 year warranty on motor
13. Rotationally molded design for housing, skirt and tank provide lighter weight, chemical resistance and styling features.
14. Design prevents solution contamination with serviceable access to the solution & recovery tanks.
15. Curved aluminum squeegee body with reversible rubber squeegees.
16. Easy "Safe" access to drive brushes for pad or brush removal without requiring tilting of the unit to rear.
17. Squeegee design provides smooth follow operation when cleaning along walls and making runs. The concave squeegee allows maximum pick-up without streaking.
18. Safety automatic "reverse to forward" switch system to prevent injury.
19. Formed one piece zinc-plated frame.
20. Aluminum brush housing with baked enamel finish.
21. Vinyl splash skirt will not corrode.

WARNING:

DO NOT OPERATE MACHINE OR CHARGER IN AREAS WHERE FLAMMABLE LIQUIDS OR GASES ARE PRESENT.

DO NOT USE OR PICK UP FLAMMABLE CHEMICALS OR LIQUIDS WITH THIS MACHINE.

The objective of this manual is to ensure that the machine is operated correctly and performs the service which we offer to our customers. Therefore, we advise **you to follow the instructions it contains scrupulously** since the manufacturer accepts no responsibility for damage to persons, or things, or damage to the machine if the machine is not operated the way described in this manual or if the maintenance and safety instructions are not fully complied with.

The instructions provided in this manual do not replace the safety instructions and technical data for installation and operation directly applied on the product, nor do they replace the safety standards current in the country of installation and the rules dictated by normal common sense.

The operator or maintenance worker must advise a person in authority of any faults or deterioration which could affect the original safety of the machine.

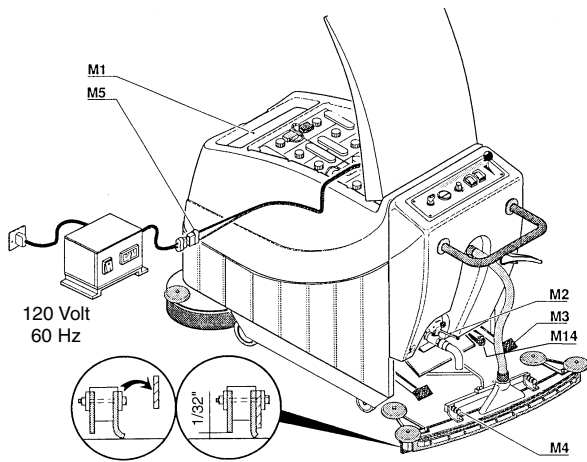

Solution Tank: The solution tank is located under the lid, at the front of the machine, with the filling-funnel **M1** in an accessible position for easy re-filling.

Note: Always empty the dirty water collection tank, as described in the next paragraph, before refilling the tank with the diluted detergent solution. The solution tank has a maximum capacity of 20 gallons (73 liters). Always use the products and the dilution quantities recommended by the seller. Never use foamy detergents. Use defoamer if excess foam develops.

Water collection tank: The dirty water collection tank should be emptied, preferably each time after use, so that the dirt does not settle there. To do this, open the ball valve **M2**, emptying dirty water into the proper drain conforming to local regulations. For sludge clean-out, open the port by loosening both knobs.

Squeegee: The squeegee has the final task of completing the drying of the floor and it is very important for it to be in the correct position. Lower the squeegee to the working position by pressing pedal **M3**. Adjust the position of the squeegee by means of the knobs **M4** so that the black rubber bar is about $\frac{1}{2}$ " (the thickness of a business card) from the floor. The squeegee behind this is in para rubber and must press on the floor with a certain amount of force. *After the first few hours the squeegee adjusts itself to the correct angle and drying becomes even better.* Squeegee pressure is adjusted by knob **M14**.

An additional squeegee blade may be added for use on very rough concrete to improve drying and eliminate squeegee vibration.

Battery installation and charging: The batteries are supplied separately and must be inserted in the special compartment provided under the lid. Apply a layer of vaseline to the terminals and connect in series as shown on page 12. Make sure that the terminals are correctly tightened. The battery charger must be installed in the place set aside for charging the machine. The charger is provided with a cable for connection to the mains, normally 120v/60HZ. Check that the voltage corresponds to the voltage indicated on the battery charger.

To charge the batteries, connect the connector of the machine to the batteries **M5** to the connector of the battery charger. The battery charger will automatically regulate the voltage to the batteries and will switch itself off when the batteries have been fully charged.

CAUTION: A) Make sure key switch is turned "OFF" and battery connector is unplugged from machine before performing any maintenance procedures. **B)** Battery acid can cause burns. When working on or around batteries, wear protective clothing and safety glasses. Remove metal jewelry. Do not lay tools or metal objects on top of batteries. **C)** Charging batteries generate explosive gases.

NO SMOKING OR OPEN FLAMES OR SPARKS. Make sure the charger has turned off before disconnecting it from the batteries. Charge batteries in a well-ventilated area with the tanks in the raised and locked position.

The area to be scrubbed: Debris and grit must be swept up before starting the scrubbing operation to avoid vacuum line blockage and to permit the detergent to perform efficiently.

Starting up and operation: Disconnect the batteries from the battery charger and connect to the machine. Then:

- Turn master switch **M6** to position 1 and press switches **M7** and **M8**.
- Lower the brush by pressing pedal **M9**.
- Lower the squeegee by pressing pedal **M3**.
- Set the detergent solution supply to minimum by adjusting knob **M12**.
- Press down the handle **M10** to drive forward. When the handle is released the machine stops.
- Adjust the speed of advance by adjusting knob **M11**.
- Finally, adjust the correct supply of the detergent as a function of the amount of dirt and speed of advance by means of lever **M12**; this is a matter of experience.

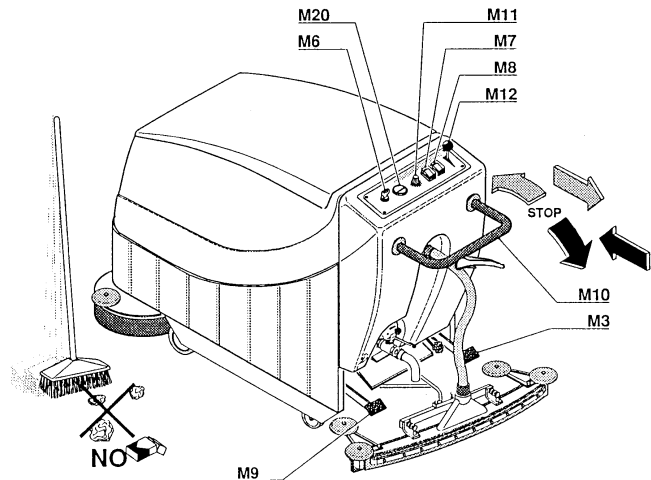

At this point the machine is ready to carry out the operations of scrubbing and drying at the same time

CAUTION: Make sure key switch is in the "OFF" position before installing pad.

Particularly dirty floors: Certain floors or areas may require special attention and, in some cases, cleaning twice. Go over the floor quickly the first time, with the squeegee raised and the brush in the working position. In this way, the detergent solution is left on the floor for a longer time and can dissolve the heavy dirt. The second time, go over the floor more slowly with both the brush and the squeegee lowered.

CAUTION: A) Loose objects on the floor can become dangerous projectiles if struck by the high-speed pad. Remove them before operating this machine. **B)** Keep machine moving to prevent damage to finish or floor. **C)** These machines are designed for level floor operations only. **DO NOT OPERATE ON RAMPS OR INCLINES** unless adequate personnel are available for assistance.

Squeegee: Every week, check the blades of the squeegee and wash them carefully. Then replace them in the correct working position (see above). If drying is not perfect even after the unit has been cleaned, replace any blades which are excessively worn. If the squeegee does not pick up enough water or streaks, lift and wipe off the blades.

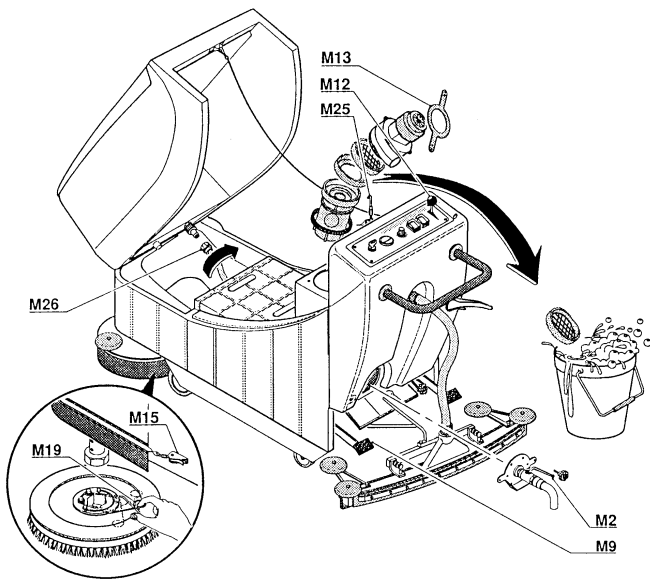

The pad driver or brush must be in good working condition because it is the component which removes the dirt.

To replace the block, pad or brush:

- Switch the machine off and disconnect the power supply.
- Lift brush up by depressing M9.
- Open the spring lever M15 or fold up the vinyl skirt. Access from your right side, facing the front of the scrubber.
- Rotate the brush by hand until the M19 spring rings are reached. Closing the M19 spring rings together by fingers (like scissors) drops the brush.
- Rotate driver/brush 180° and firmly pull it out from the scrubber.

The machine is supplied with a pad driver. Brushes in tynex, poly and steel are available on request, together with floor pads recommended for use with the pad driver. **Black** for stripping, **Green** for deep scrub, **Blue** for cleansing and **Red** for light scrub.

Water collection tank: This tank should be cleaned every week. Lift the lid and remove the panel or funnel M2 of the solution tank. Remove the strap M13 and lift the vacuum motor out of its seat. Thoroughly clean the filter and wash out the dirt deposited in the tank with a jet of water, allowing it to drain out through valve or port M2. If necessary, replace filter.

Batteries: Check the level of the electrolyte liquid by carefully removing plugs from top of battery and topping off with distilled water, when the level drops below the plates of the battery. Keep the batteries clean and dry with antistatic cloths. When charging the batteries lift the top lid of the machine to allow the gas which is generated to escape. **This gas can cause explosions in closed environments** and, therefore, it is advisable to carry out battery charging in well-ventilated environments.

WARNING! Do not operate machine or charger in areas where flammable liquids or gases are present. Do not use or pick up flammable chemicals or liquids with this machine.

CAUTION: Make sure all caution, warning and instructional decals are in place and legible. Replace damaged or missing labels.



This scrubber-drier has been designed to the strictest safety standards but the user must still use the machine with care and caution.

Here are a few rules which must be respected:

- Never leave the machine unattended, particularly when there are children around.
- Always switch off the machine when filling the solution tank.
- Never attempt to make emergency repairs or use non-original spare parts.
- Check the wear and deterioration of the materials at intervals and ask the seller for assistance.
- Do not smoke or expose open flames or sparks in the vicinity of the batteries (portable grinders, welders, etc.).
- Do not take current from the batteries using ad hoc clips or other forms of temporary connections.
- Do not rest metal tools or instruments on the batteries because the electrolyte liquid is corrosive.

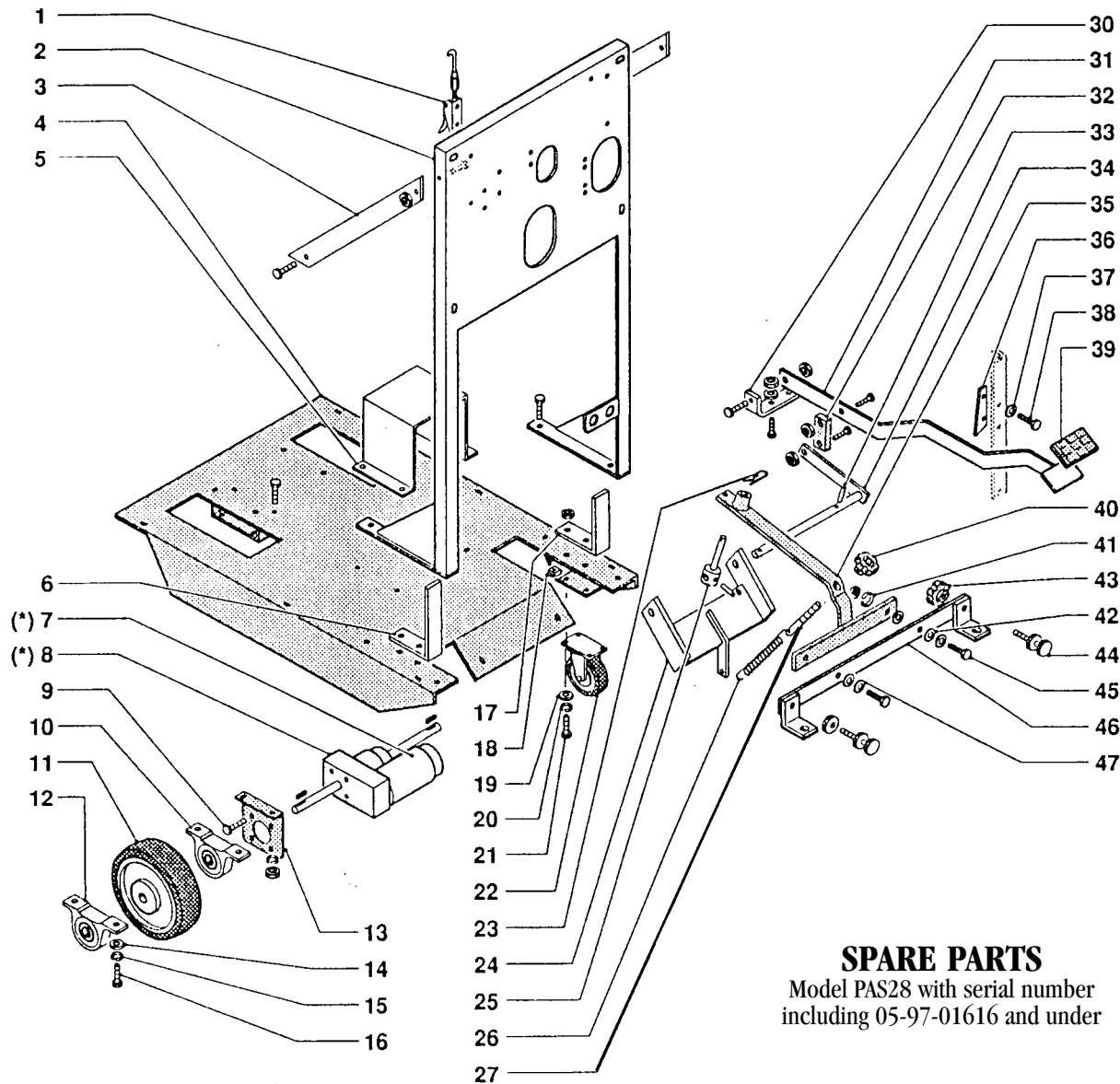

SPARE PARTS
 Model PAS28 with serial number
 including 05-97-01616 and under

Pos	Part No.	Description
1	PAS122	Hook
2	PAS177	Back frame
3	700.003	Yoke
4	700.004	Frame
5	700.005	Support
6	700.006	Left pedal stop
7	PAS221	Drive motor (*)
8	PAS220	Differential gear (*)
(*)	PAS60	Drive motor, differential
9	PAS223	Screw
10	PAS61	Support
11	PAS62	Wheel
12	PAS61	Bearing and housing
13	PAS222	Yoke
14	PAS188	Washer
15	PAS907	Lock washer
16	PAS190	Screw
17	700.017	Right pedal stop
18	850.033	Cage nut
19	PAS188	Washer

Pos	Part No.	Description
20	PAS907	Lock washer
21	PAS190	Screw
22	PAS51	Swivel caster
23	PAS266	Split pin
24	PAS264	Support
25	PAS19	Pin
26	PAS31	Spring
27	PAS63	Tie rod
30	PAS257	Pedal bracket
31	PAS256	Squeegee pedal
32	PAS265	Cross member
33	PAS280	Elastic pin
34	PAS195	Lever
35	PAS155	Lever
36	PAS259	Cam
37	430.109	Bracket
38	PAS147	Screw
39	PAS14	Pedal cover

Pos	Part No.	Description
40	PAS64	Knob
41	PAS907	Lock washer
42	PAS212	Nylon washer
43	PAS33	Knob
44	PAS34	Regulator, squeegee
45	PAS213	Stainless steel screw
46	PAS214	Support
47	PAS188	Washer

SPARE PARTS
 Model PAS28 with serial number
 above 05-97-01616

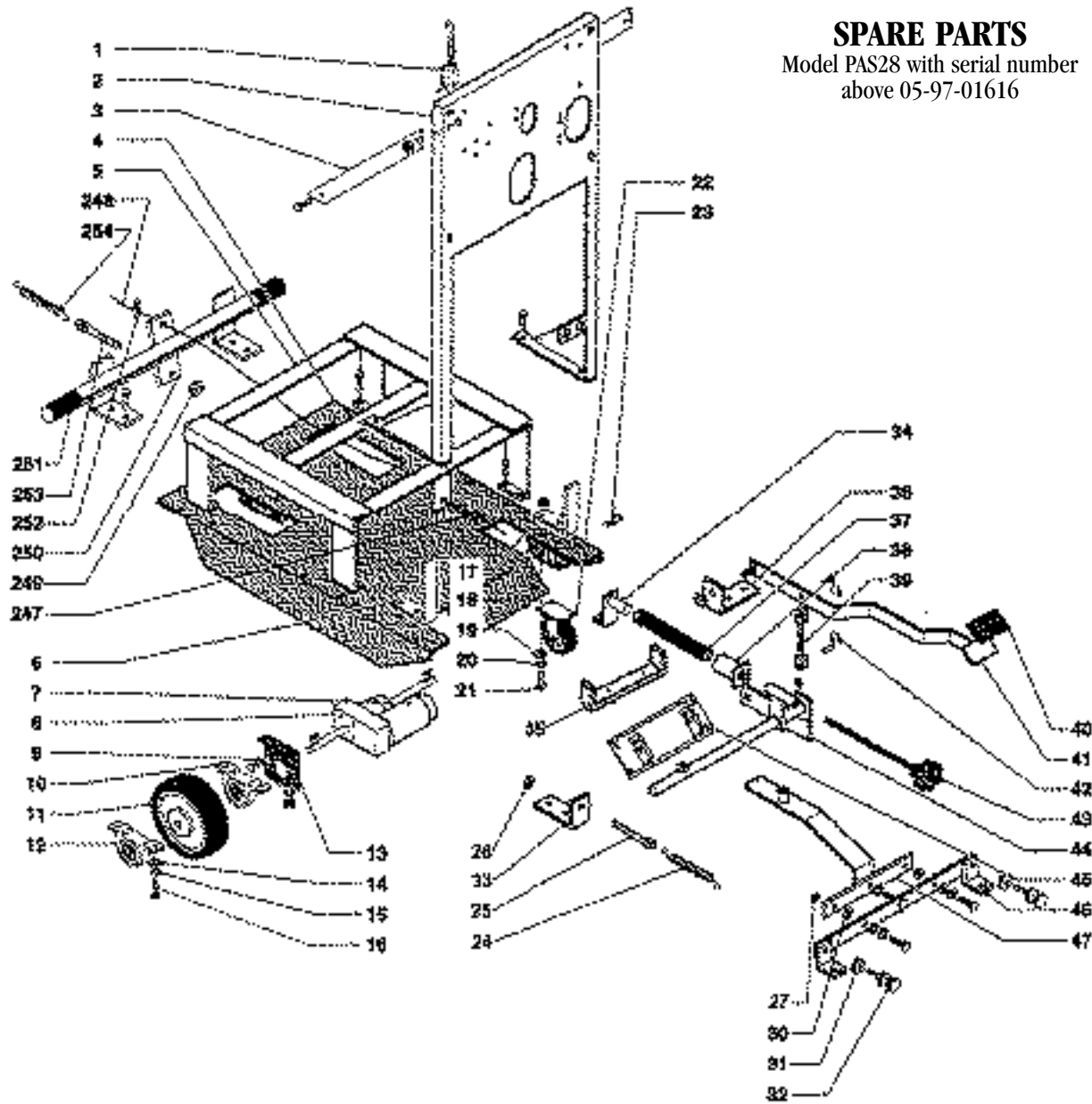

Pos	Part No.	Description
1	PAS122	Hook
2	PAS177	Back Frame
3	700.003	Yoke
4	700.004	Frame
5	700.005	Support
6	700.006	Left pedal stop
7	PAS221	Drive motor (*)
8	PAS220	Differential gear (*)
(*)	PAS60	Drive motor, differential
9	PAS223	Screw
10	PAS61	Bearing and housing
11	PAS62	Wheel
12	PAS61	Support
13	PAS222	Yoke
14	PAS188	Washer
15	PAS907	Lock washer
16	PAS190	Screw
17	700.017	Right pedal stop
18	850.033	Nut Clip

Pos	Part No.	Description
19	PAS188	Washer
20	PAS907	Lock washer
21	PAS190	Screw
22	PAS51	Caster/Steel Housing
23	PAS266	Split pin
24	PAS31	Spring
25	PAS63	Pin/Tie Rod
26	PAS176	Nut
27	PAS176	Nut
30	PAS212	Washer
31	PAS33	Ring Nut
32	PAS34	Regulator
33	PAS280	Support
34	PAS195	Support, stud
35	PAS155	Support
36	PAS257	Bracket
37	430.109	Spring
38	PAS147	Stop

Pos	Part No.	Description
39	PAS14	Tie rod
40	PAS64	Pedal cover
41	PAS14	Foot Pedal
42	PAS918	Pin
43	PAS65	Pressure regulator, squeegee
44	PAS66	Lever
45	PAS213	Support
46	PAS214	Support
47	430.118	Lever
247	PAS170	Regulator
248	PAS168	Cable
249	PAS176	Nut
250	PAS178	Brake Support
251	PAS174	Rubber tube
252	PAS173	Clamp
253	PAS63	Pin/Tie Rod
254	501.141	Spring

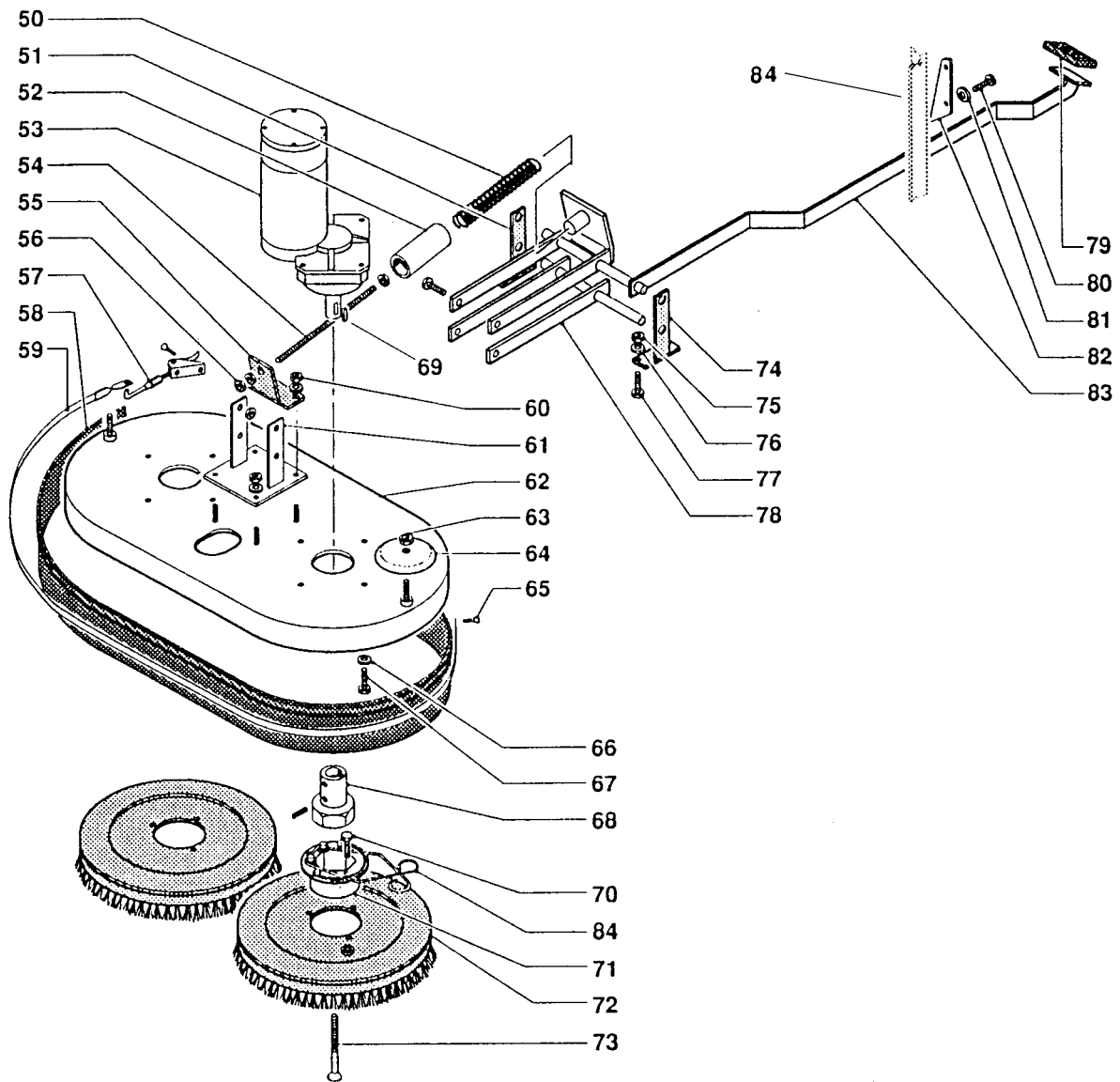

Pos	Part No.	Description
50	PAS156	Pressure spring
51	650.112	Right support
52	650.105	Spring support
53	PAS4	Geared motor
54	PAS163	Tie rod
55	PAS164	Support
56	850.058	Nut
57	PAS122	Hook & Latch
58	PAS2	Bumper
59	PAS108	Strap, Bumper
60	PAS176	Nut
61	PAS165	Support
62	PAS225	Motor plate
63	PAS924	Nut
64	PAS1	Vibration damper wheel
65	PAS926	Screw
66	PAS146	Washer

Pos	Part No.	Description
67	430.072	Screw
68	PAS5	Coupling, half
69	PAS101	Key, machine
70	PAS65	Screw
71	PS 6A	Support with short spring
72	PAS67	Poly Scrub brush (2 brushes per set)
72	PAS68	Nylo Grit 2 brushes
72	PAS130	Strata Grit 2 brushes
72	PAS94	Scrub Grit II 2 brushes
72	PAS69	Pad holder
72	PAS133	Powr-Scruff brush
73	PAS111	Bolt
74	650.114	Left support
75	PAS176	Nut
76	PAS188	Washer

Pos	Part No.	Description
77	PAS167	Screw
78	650.113	Lower lever
79	PAS14	Foot Cover
80	PAS147	Screw
81	430.109	Washer
82	PAS258	Cam
83	650.108	Brush lift pedal
84	PAS7	Spring for support

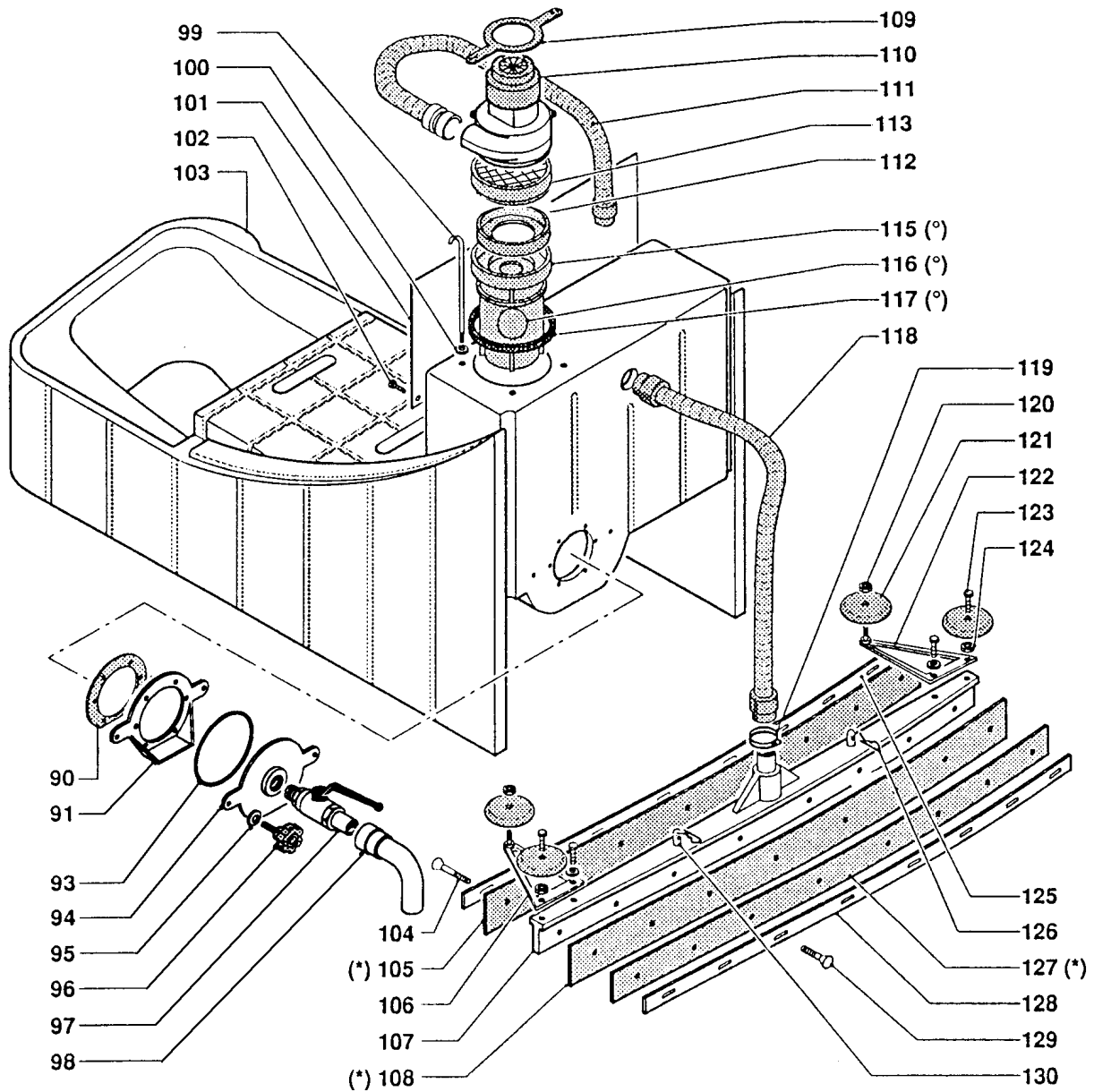

Pos	Part No.	Description
90	PAS70	Seal
91	PAS71	Fixed flange
93	PAS72	Seal
94	PAS73	Movable flange
95	PAS186	Washer
96	PAS74	Knob
97	PAS75	Dump valve
98	PAS187	Fitting
99	PAS150	Tie rod
100	PAS146	Washer
101	700.101	Plate
102	PAS147	Screw
103	700.103	Water collection tank
104	PAS223	Screw
105	PAS145	Black rubber (*) ▲
106	PAS181	Left vibration damper

Pos	Part No.	Description
107	PAS77	Squeegee body ▲
108	PAS143	Para rubber (*) ▲
109	PAS15	Motor stop ring
110	1924	Vac motor
111	PAS37	Flex hose
112	PAS102	Motor seal
113	F909	Screen/Filter
115	PAS85	Float support (°)
116	PAS210	Float (°)
117	PAS103	Seal (°)
(°)	PAS17	Complete float
118	PAS80	Intake hose
119	PAS191	Hose clamp
120	PAS935	Nut
121	PAS1	Vibration damper wheel

Pos	Part No.	Description
122	PAS182	Right vibration damper
123	PAS936	Screw
124	PAS937	Nut
125	650.178	Outer bar
126	PAS959	Split pins
127		Optional Squeegee Blade (*) ▲
(*)	PAS76	Squeegee Blade Set
128	650.181	Outer bar
129	PAS223	Screw
130	PAS942	Support stud
131	700.131	Tank
▲	PAS78	Squeegee assembly complete
▲	PAS90	Heater
▲		Not Illustrated

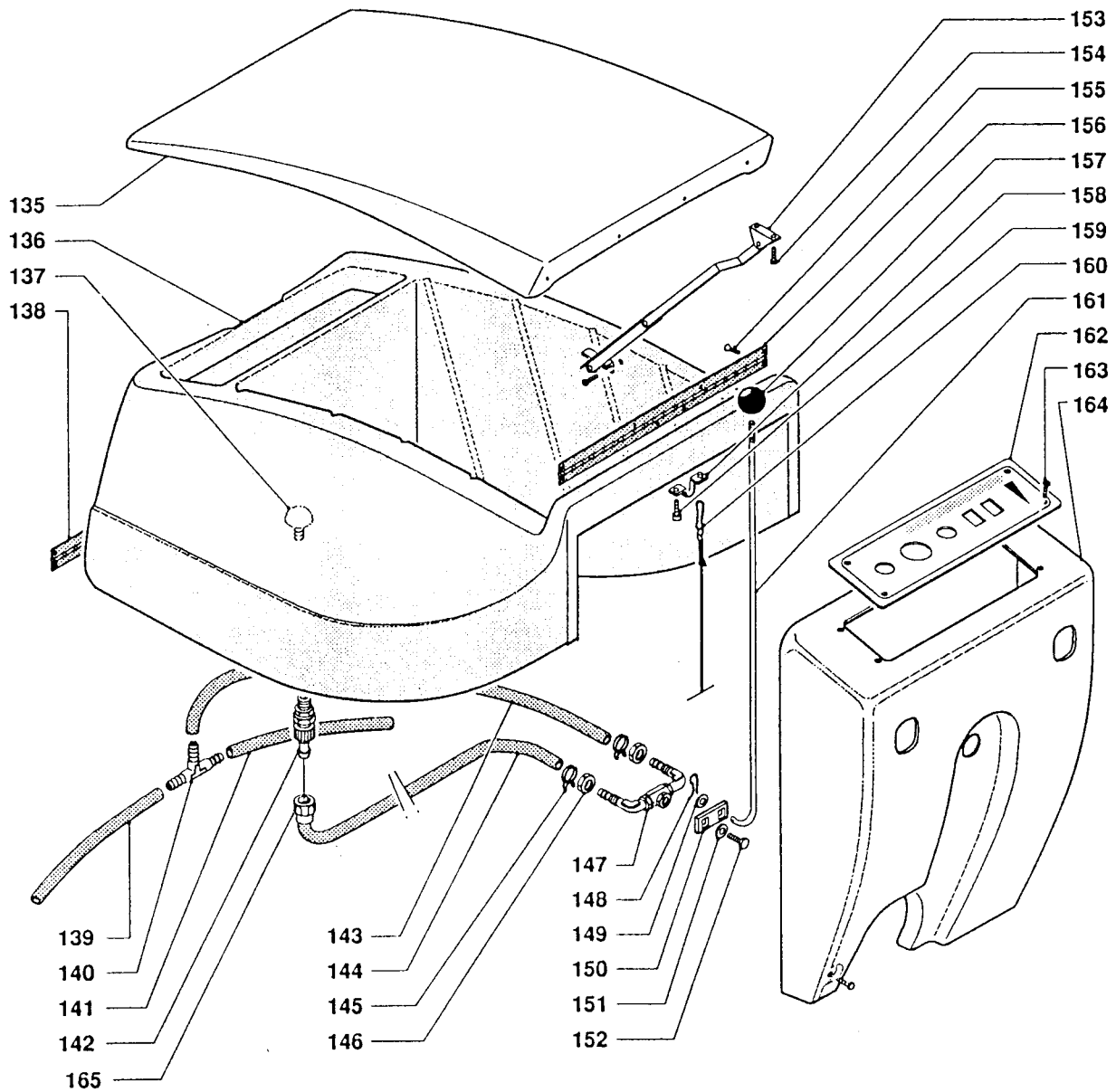

Pos	Part No.	Description
135	PAS806	Lid
136	PAS805	Solution tank
137	PAS3	Filter
138	700.138	Hinge
139	PAS288	Hose
140	PAS82	Hose fitting
141	PAS288	Hose
142	PAS83	Quick coupling
143	PAS288	Hose
144	PAS288	Hose
145	430.091	Hose collars

Pos	Part No.	Description
146	400.161	Nut
147	PAS12	Solution Valve
148	500.056	Split pin
149	PAS146	Washer
150	500.051	Lever
151	500.053	Washer
152	500.054	Screw
153	PAS84	Lid support/Hinge
154	PAS153	Screw
155	700.155	Screw
156	PAS110	Hinge

Pos	Part No.	Description
157	PAS11	Knob
158	700.158	Support
159	430.056	Screw
160	700.160	Hook and cord
161	PAS155	Rod
162	PAS161	Control panel
163	PAS153	Screw
164	700.164	Housing

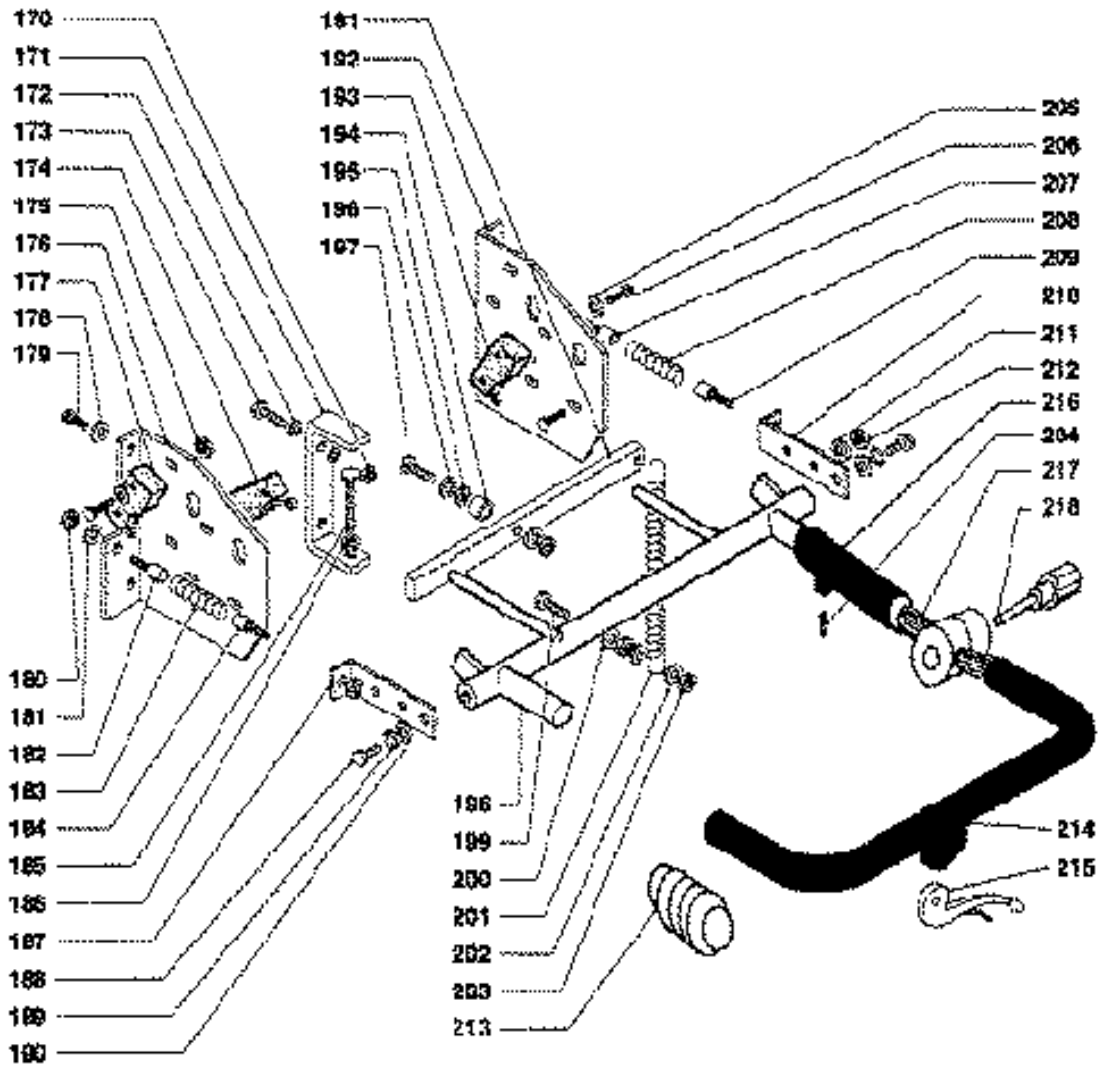

ref#	order	description	each
170	430.025	Nut	.10
171	850.444	Support	.10
172	PAS146	Washer	.10
173	PAS223	Screw	.10
174	PAS56	Micro switch	.10
175	430.296	Nut	.10
176	850.468	Handle support	.10
177	PAS56	Micro switch	.10
178	PAS146	Washer	.10
179	430.072	Screw	.10
180	PAS149	Nut	.10
181	PAS146	Washer	.10
182	700.182	Screw	.10
183	850.445	Spring	.10
184	700.182	Screw	.10
185	650.372	Screw	.10
186	PAS176	Nut	.10
187	850.446	Souare	.10
188	PAS936	Screw	.10
189	PAS907	Lock washer	.10
190	PAS188	Washer	.10
191	PAS136	Yoke	.10
192	850.496	Handle support	.10
193	PAS56	Micro interrupteur	.10
194	PAS138	Spacer	.10

ref#	order	description	each
195	PAS935	Nut	.10
196	PAS137	Washer	.10
197	PAS936	Screw	.10
198	650.422.1	Lever	.10
199	PAS197	Screw	.10
200	PAS146	Washer	.10
201	PAS139	Spring	.10
202	PAS146	Washer	.10
203	PAS149	Nut	.10
204	430.16	Dowel	.10
205	430.297	Washer	.10
206	430.299	Screw	.10
207	700.182	Screw	.10
208	850.445	Spring	.10
209	700.182	Screw	.10
210	850.446	Souare	.10
211	700.211	Washer	.10
212	PAS149	Nut	.10
213	650.423.1	Rubber tube	.10
214	430.323.1	Handle	.10
215	PAS166	Brake lever	.10
216	PAS338	Handle	.10
217	PAS339	Coupling	.10
218	PAS337	Knob	.10

* call for price and availability

SPARE PARTS

Model PAS28 with serial number
05-97-01616 and under

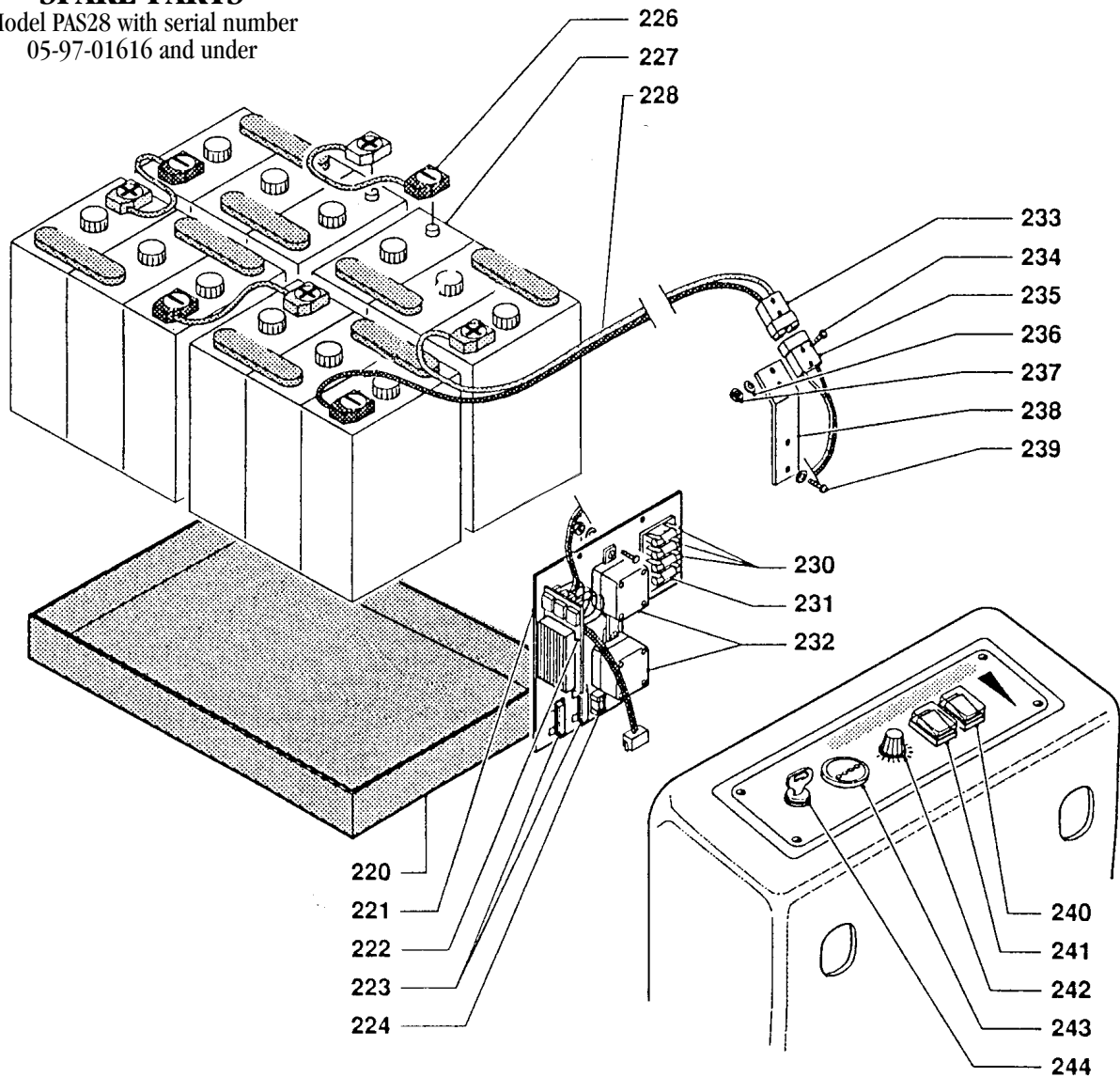

Pos	Part No.	Description	Pos	Part No.	Description
220	PAS86	Battery tray	238	650.328	Yoke
221	PAS218	Component support	239	430.072	Screw
222	PAS87	Micro Processor	240	PAS54	Vac switch
224	PAS119	6.3 Amp Fuse	241	PAS54	Brush switch
226	PAS141	Cable Jumper	242	PAS88	Knob
228	PAS140	Neg. & Pos. cable	243	PAS89	Battery gauge
230	PAS117	16 Amp Fuse	244	PAS53	Master switch
231	PAS118	20 Amp Fuse			
232	PAS57	Solenoid			
233	PAS59	Connector			
234	430.299	Screw			
235	PAS59	Connector			
236	430.297	Washer			
237	430.296	Nut			

SPARE PARTS

Model PAS28 with serial number
over 05-97-01616

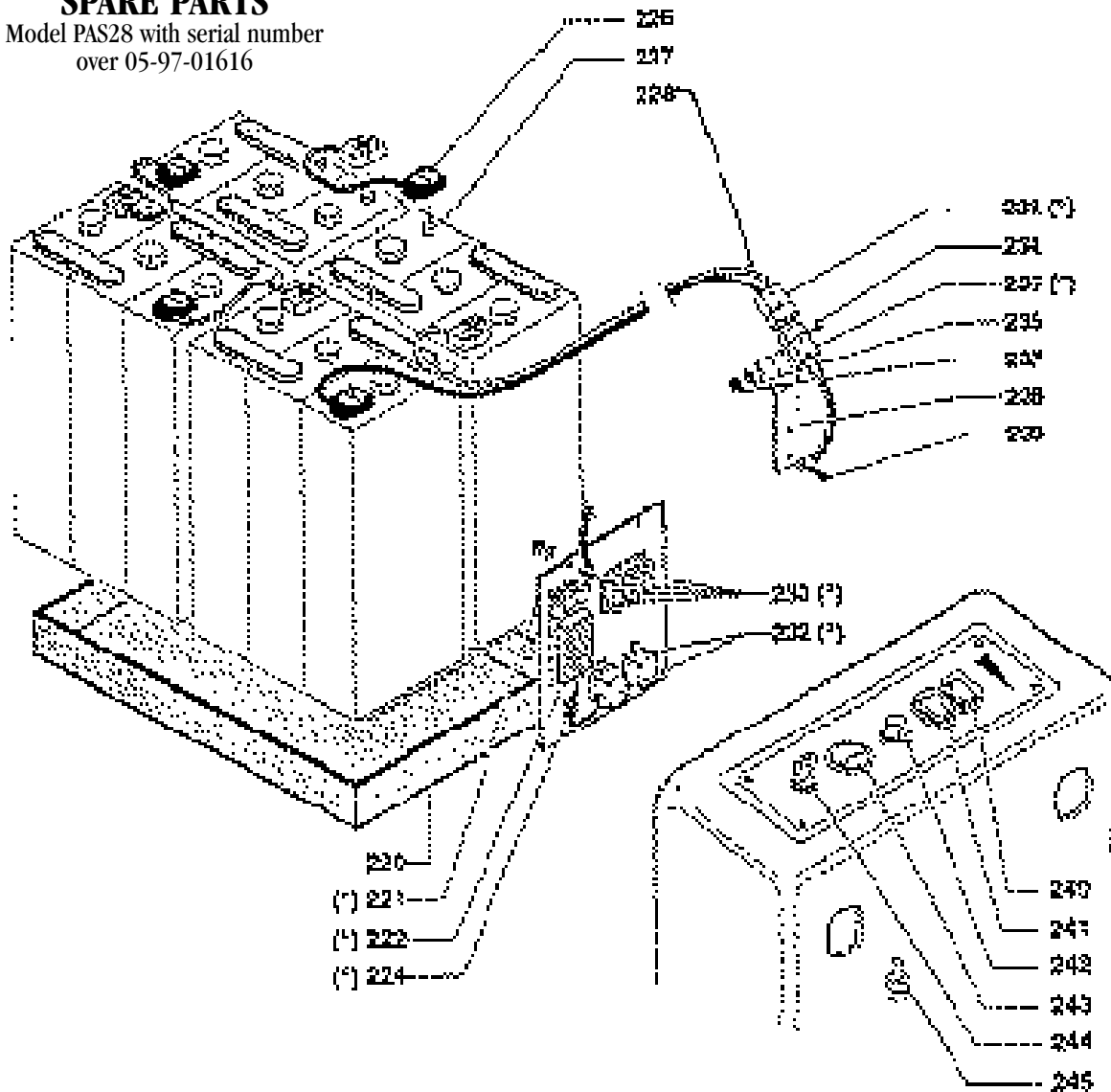

Pos	Part No.	Description	Pos	Part No.	Description
220	PAS86	Battery tray	238	650.328	Yoke
221	PAS218	Component support	239	430.072	Screw
222	PAS87	Micro Processor	240	PAS54	Vac switch
224	PAS119	6.3 Amp Fuse	241	PAS54	Brush switch
226	PAS141	Cable Jumper	242	PAS88	Knob
228	PAS140	Neg. & Pos. cable	243	PAS89	Battery gauge
230		30 Amp ATC Fuse	244	PAS53	Master switch
232	PAS57	Solenoid			
233	PAS59	Connector			
234	430.299	Screw			
235	PAS59	Connector			
236	430.297	Washer			
237	430.296	Nut			

Microprocessor Diagnostic Signals

The Model PAS28 with serial numbers above 05-97-01616 have an on board diagnostic system as standard equipment. The number of light flashes denotes service location.

1	Flash	Microswitches
2	Flashes	Batteries discharged
3	Flashes	Code not in use
4	Flashes	Traction motor
5	Flashes	Microprocessor
6	Flashes	Potentiometer
7	Flashes	Microprocessor to hot
8	Flashes	Traction motor is moving
9	Flashes	Software Problem

Model PAS28 with serial number
05-97-01616 and under

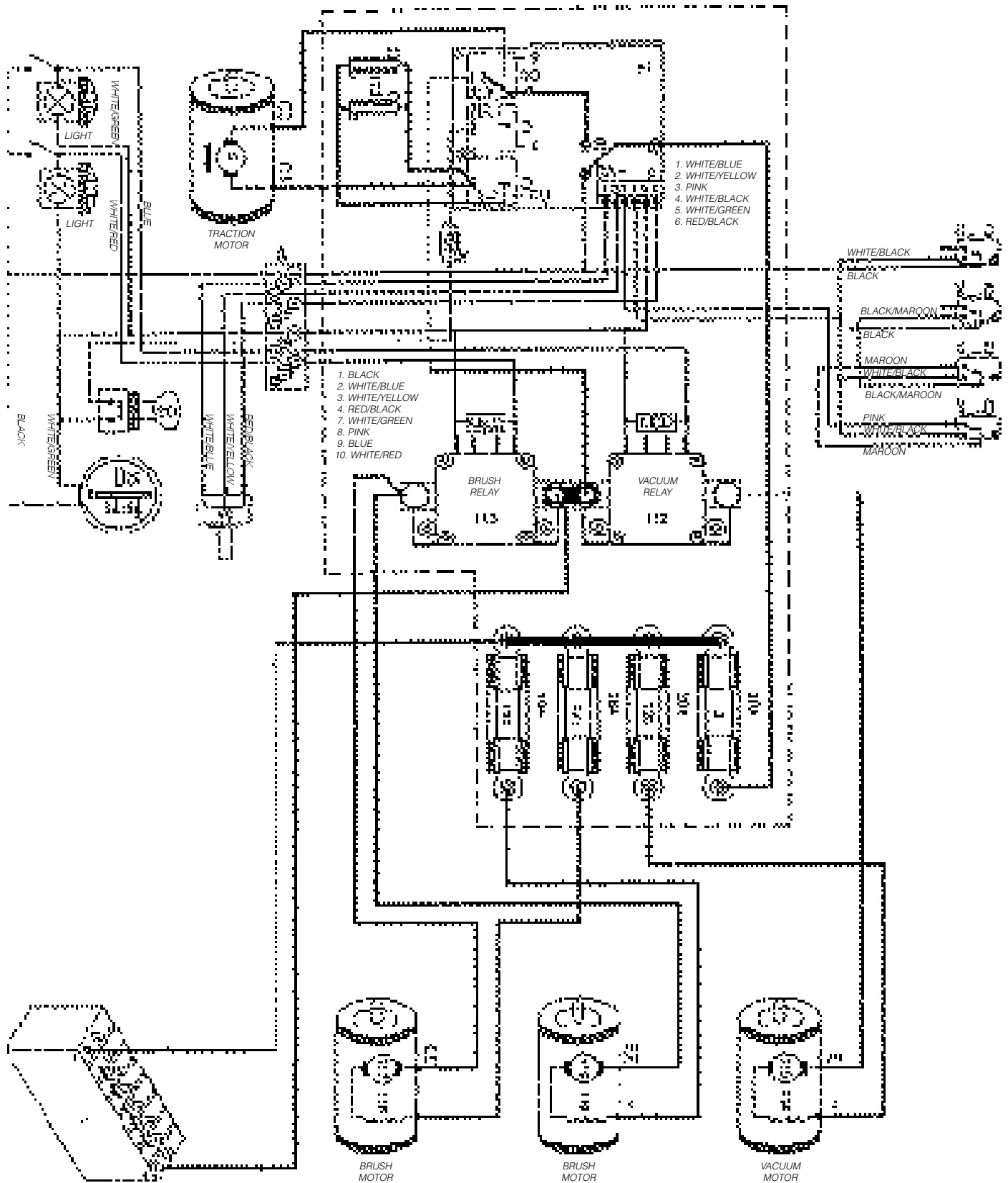

Model PAS28 with serial number
above 05-97-0616

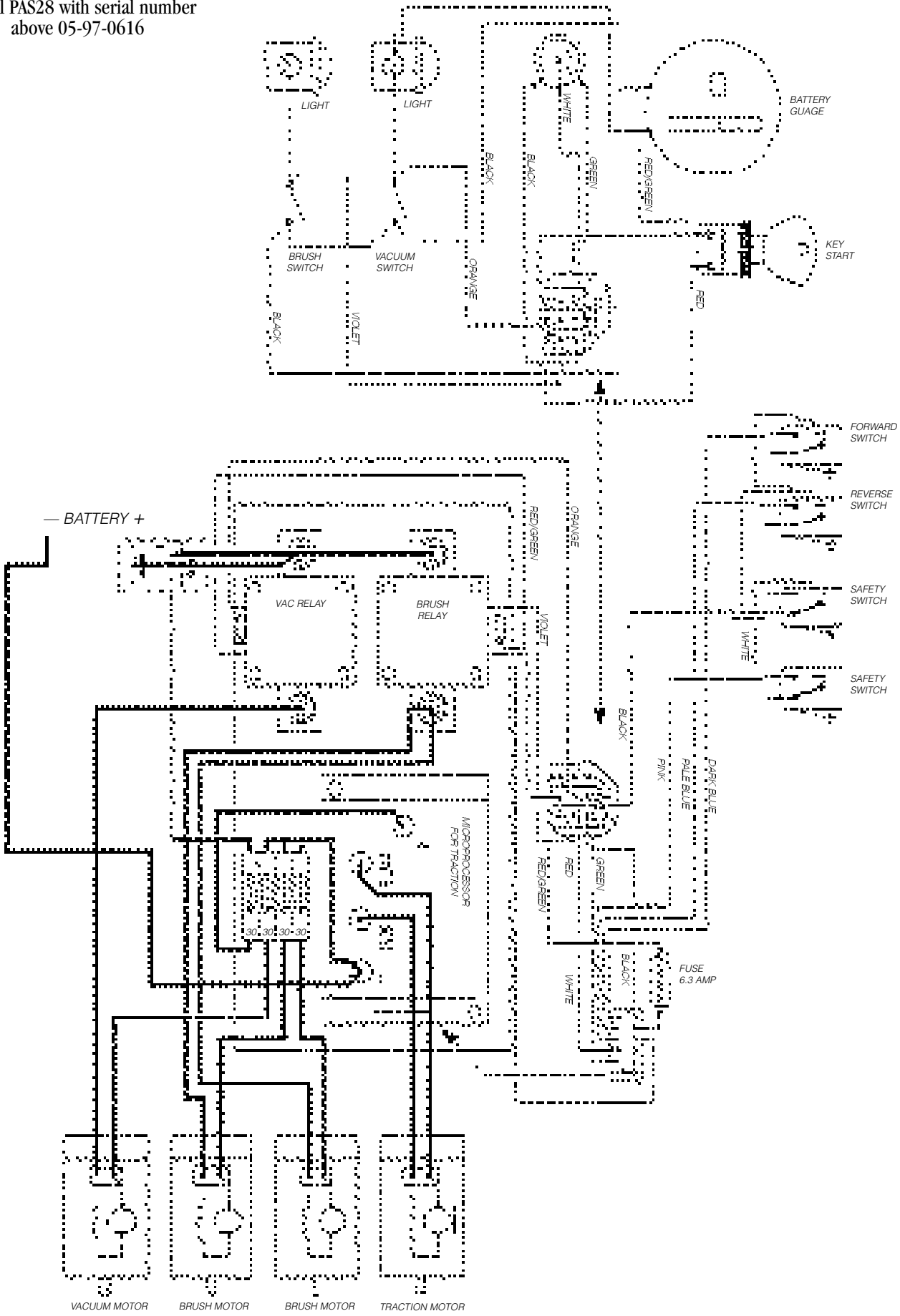



A Tacony Company

3101 Wichita Court • Ft. Worth, TX 76140-1710