

Predator Automatic Scrubber

OPERATORS MANUAL AND PARTS LIST

Model PAS28-32DX



WARNING: OPERATOR MUST READ AND UNDERSTAND THIS MANUAL COMPLETELY BEFORE OPERATING THIS EQUIPMENT.

IMPORTANT SAFETY INSTRUCTIONS

All operators must read, understand and practice the following safety instructions. They will be repeated occasionally throughout this manual, and additional cautions may be added for specific cases.

- **CAUTION:** Operators must read and understand this manual completely before operating this equipment.
- **CAUTION:** Make sure key switch is in the “OFF” position before installing pad.
- **CAUTION:** Loose objects on the floor can become dangerous projectiles if struck by the high-speed pad. Remove them before operating this machine.
- **CAUTION:** Keep hands and feet away from revolving pad.
- **CAUTION:** Keep machine moving to prevent damage to finish or floor.
- **CAUTION:** Make sure key switch is turned “OFF” and battery connector is unplugged from machine before performing any maintenance procedures.
- **CAUTION:** Maintenance and repairs must be performed by authorized personnel.
- **CAUTION:** Battery acid can cause burns. When working on or around batteries, wear protective clothing and safety glasses. Remove metal jewelry. Do not lay tools or metal objects on top of batteries.
- **CAUTION:** Do not operate this equipment in bare feet or with open-toed shoes or sandals.
- **CAUTION:** Charging batteries generate explosive gases. ***NO SMOKING OR OPEN FLAMES OR SPARKS.*** Make sure the charger has turned off before disconnecting it from the batteries. Charge batteries in a well-ventilated area with the tanks in the raised and locked position.
- **CAUTION::** Store or park this machine on a level surface only. Remove key from switch if machine is left unattended.
- **CAUTION::** Do not operate machine or charger in areas where flammable liquids or gases are present. Do not use or pick up flammable chemicals or liquids with this machine.
- **CAUTION:** Make sure all caution, warning and instructional decals are in place and legible. Replace damaged or missing labels.
- **CAUTION:** These machines are designed for level floor operations only. ***DO NOT OPERATE*** on ramps or inclines unless adequate personnel are available for assistance.
- **CAUTION:** Do not expose electrical components to water or other liquids. To clean machine wipe down with a damp cloth.

WARNING:

DO NOT OPERATE MACHINE OR CHARGER IN AREAS WHERE FLAMMABLE LIQUIDS OR GASES ARE PRESENT.

DO NOT USE OR PICK UP FLAMMABLE CHEMICALS OR LIQUIDS WITH THIS MACHINE.

POWR-FLITE PREDATOR AUTOMATIC SCRUBBER

This manual refers to a battery powered automatic floor scrubber. Designed to be simple, easy to operate and safe, with maneuverability and automatic variable electronic drive. Routine maintenance has been simplified and reduced to the minimum to keep equipment on the job.

The customer must make sure that the operators have read the contents of this manual and that they adhere strictly to the indications listed. Powr-Flite does not accept any responsibility for damage caused to persons and/or property, or to the equipment itself if the conditions described below are not respected. This manual is an integral part of the machine; it must be carefully preserved for the lifetime of the machine, right up to the point of scrapping. Unauthorized reproduction in whole or in part of the text or diagrams is prohibited.

This manual describes a battery-powered floor cleaner and dryer. It is a model of a high power rating which puts it at the top of its class. It has been designed for ease of use, manageability and safety; its motorized drive and electronic control render it no strenuous to operate even for female personnel. Maintenance has been simplified and reduced to a minimum in order to allow even untrained staff to carry necessary servicing operations.

THE PRINCIPLE CHARACTERISTICS ARE:

- Galvanized sheet steel bodywork formed to give maximum strength at minimum weight;
- Reinforced polyethylene chassis in an elegant and indestructible design;
- Base in sheet thick 30/10 mm with polyethylene cover;
- Polyethylene tanks resistant to battery chemicals and to the most widely diffused industrial solvents;
- Polyurethane coated wheels;
- Reduction motor for brushes with lifetime purification;
- Differential motor for advancement lubricated to life;
- By Pass suction motor for liquids;
- Ergonomic control panel with protected switches;
- Nylon drying blade with para rubber wiper.

The floor cleaner is intended for cleaning and washing level floors in closed spaces using appropriate detergents. This manual serves to guarantee the correct use of the machine thus supporting the service that we offer the customer. You are advised to adhere strictly to the instructions contained in this manual since the manufacturer does not accept responsibility

for any damage caused to persons or to property, or to the machine itself if it is not used in the way described here or if the safety and maintenance instructions are not followed.

The instructions set out in this manual do not substitute the safety measures and technical specifications to be applied directly to the product for installation and operation, nor the safety regulations in force in the country where it is used or the rules of common sense. The installation or maintenance personnel must report any defects or deterioration that might compromise the safety of the machine. The standard cleaner is not equipped to operate in inflammable or explosive environments; an anti-inflammable machine is available on request.

The personnel responsible for operating the machine must have specific professional training or must have experience of using machines of this type. In order to prevent damage to people or to property, we advise the customer to instruct adequately the operators on any risks related to the use of this machine. The operator must always make use of the protective measures prescribed by the laws of the country in which the machine is used as well as additional protection provided by the employer (safety shoes, overalls, safety glasses, etc.).

Personnel employed for the use or maintenance of the machine must be expert, knowledgeable and mature for the tasks described and must be reliable for interpreting correctly the contents of this manual and for guaranteeing safety and attention to detail in the inspections. The responsibilities of the personnel authorized to use the machine are at the discretion of the customer. Maintenance personnel must have the specific characteristics (maintenance technician) necessary for correctly interpreting diagrams and instructions.

Powr-Flite declines all responsibility for damage of any kind resulting from imprudent use by expert or inexpert personnel who have not operated the machine in accordance with this manual. The installation must be carried out in accordance with the laws in force in the country where it is installed; Powr-Flite is not responsible for equipment upstream of the cleaner.

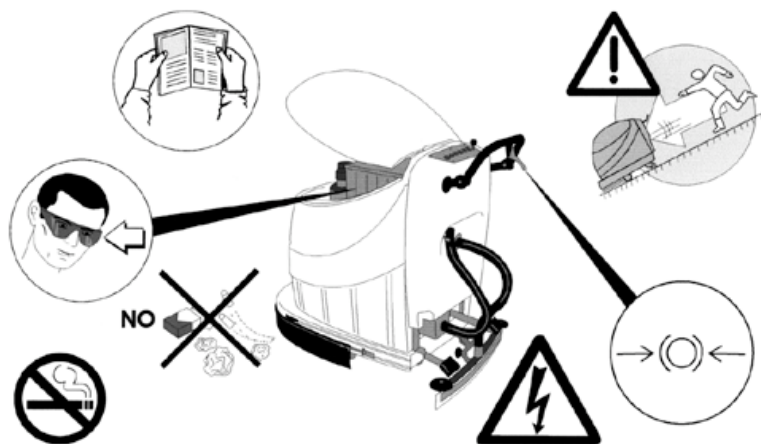

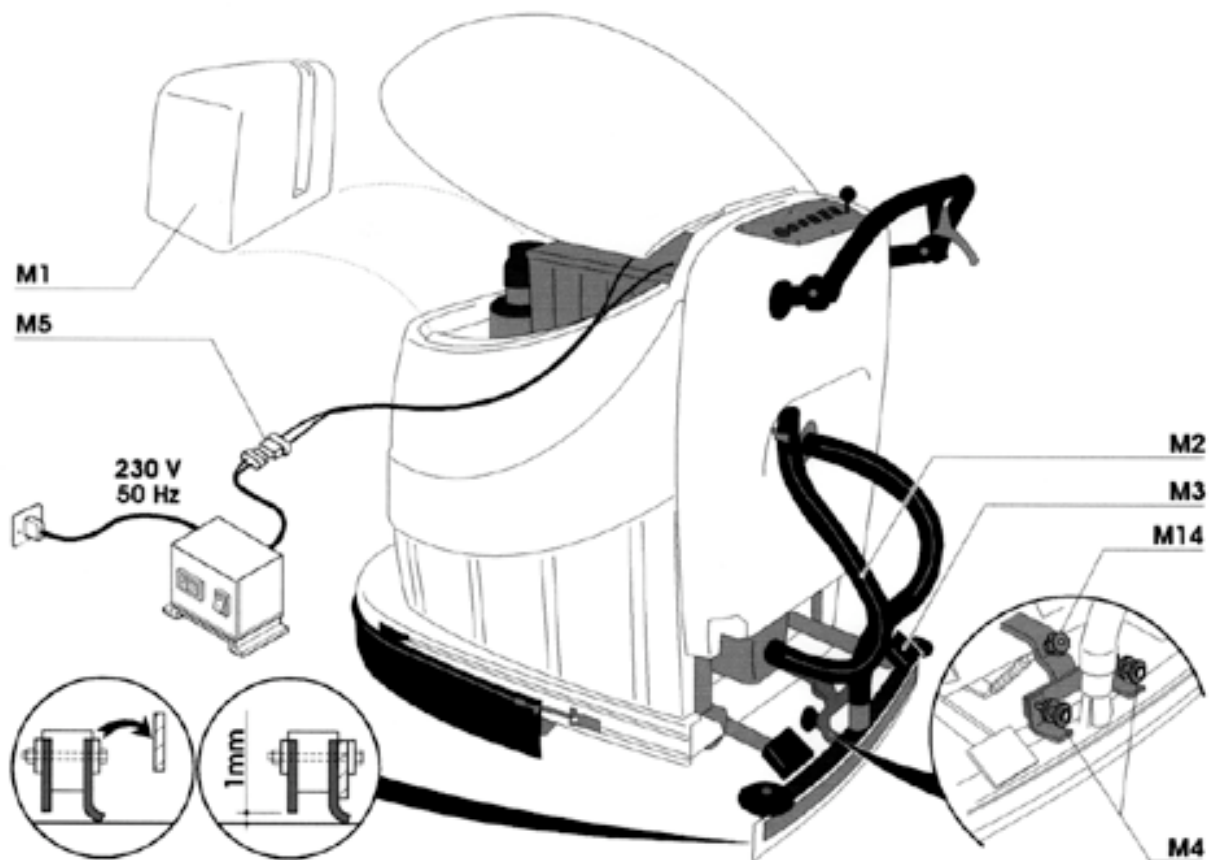

The customer must use exclusively original spare parts and fit them in the intended way. Do not leave any objects of any kind on the floor as they may be thrown at high speed by the brushes. Keep feet and hands clear of the moving brushes.

Ensure that the main power key switch is in the OFF position and that the batteries are disconnected before carrying out any maintenance and/or filling the tanks with detergent and/or changing the brushes.

Authorized personnel must carry out maintenance procedures. Do not carry out any un-safe or temporary repairs or use non-original spare parts. Regularly check the wear and deterioration of the materials and, if necessary, call out your regular supplier.

When working near the batteries use protective glasses and clothing. Remove any metal object. Do not rest metal tools or equipment of any type on the batteries. Recharging the batteries produces explosive gas.

DO NOT SMOKE, LIGHT FLAMES OR MAKE SPARKS.

Ensure that the charger is switched off before disconnecting it from the batteries. Recharge the batteries in a well-ventilated area and with the cover fixed in the open position. Do not draw current from the batteries with makeshift connectors, clips or contacts. Park the cleaner on a flat and level floor and engage the parking brake.

The electrical parking brake must be activated in the startup operation of the scrubber drier using the lever M30. In order to move the machine without batteries it is necessary to disarm manually the brake pulling back the lever.

ATTENTION: for safety reasons verify that the parking brake is working (pull the lever) once the batteries are connected!

The electromagnetic brake is automatically activated every time the scrubber drier is turned off

If the cleaner is left unattended remove the key from the main power switch. Do not leave the cleaner unattended particularly if children are present. Do not use or install the cleaner in places where inflammable gases or liquids are present. Do not use inflammable liquids or chemicals with this cleaner. Ensure that the instruction manual and warnings are always to hand and are legible. Replace any torn or missing pages. This machine must only be used on flat and level surfaces.

DO NOT USE IT ON IN-CLINED SURFACES without the assistance of the appropriate personnel. Do not operate the machine in bare feet, with sandals or any kind of open footwear. Do not wet electrical components with water or any other liquid. Dry the machine with a cloth.

Powr-Flite is not responsible for the disposal or production of products necessary for its operation; e.g. batteries, detergents, etc.; the customer himself must, therefore, arrange for the disposal of sub-stances harmful to the environment in accordance with the laws of the country in which it is used. The same precautions should be taken when the machine is scrapped.

The machine generates a sound pressure level n (noise) in an industrial environment (warehouse/ shop floor) that is less than below 80 dB and is therefore absolutely harmless for the operator. However, in other surround-

ings, this level may be exceeded in which case the customer must provide appropriate protection (ear defenders) as well as notices to promote their use and periodic hearing examinations.

The operator must not wear clothing with wide sleeves, laces or belts; he must not approach the machine with bare or wet feet; he must not pull out the plug by pulling the cable; must not smoke if the environment or products used do not allow it.

- For lifting and transporting use only specialized personnel (slingers, crane operators, etc.) with proper lifting gear which is suitable for the weight of the various components.
- Transport (especially by road) must be carried out with in the correct way and with the adequate means so as to protect the components (especially the electronic ones) from violent shocks, humidity, vibration, etc; the machines are supplied with wheels and therefore need to be securely anchored before beginning transportation.
- We remind you that packing material (wood, nails, paper, cellophane, metal staples, adhesive tape, straps, ropes, etc.) may cause cuts or wounds and should be handled with care. These must be removed with appropriate tools and should not be left in the care of irresponsible people (e.g. Children); the same applies to the un-packing tools (scissors, hammers, pliers, knives, etc.).
- On specific request, Powr-Flite will pack the machines appropriately but this does not eliminate the above safety notes.

During movement, suspended loads made up of machine components or parts represent a collision, risk, it is the responsibility of the customer to highlight this danger.

WARNING: before attempting to adjust or prepare the machine or to fill the tanks, make sure that the power supply is disconnected.

Detergent tank: The detergent tank is positioned underneath the upper cover at the front of the machine with the filter hole M1 easily accessible for easy refilling. Before filling the tank with correctly diluted detergent, empty the waste collection tank as described in the following paragraph; obviously this step is not required for the first time of filling. The capacity of the detergent tank is 80lt. Only use the quantities and dilution recommended by the detergent supplier and use only non-foaming detergents.

Waste tank: The waste tank should be emptied (preferably after each use) so as not to let the dirt settle; to do this, remove the cap covering the drain tube M2 which is held in place by a retaining spring, and put in a position so that it drains. Always abide by the environmental regulations of the country where the machine is used.

Wiper blade: The floor wiper serves to finish the drying operation and it is very important to ensure it is in the correct position: lower the wiper to its working position using the foot pedal M3; level the wiper using the knobs M4 so that the black rubber strip is approximately 1/4" above the floor.

The remaining para rubber strips must wipe the floor with a certain amount of pressure; after the first few hours of operation the rubber wipers

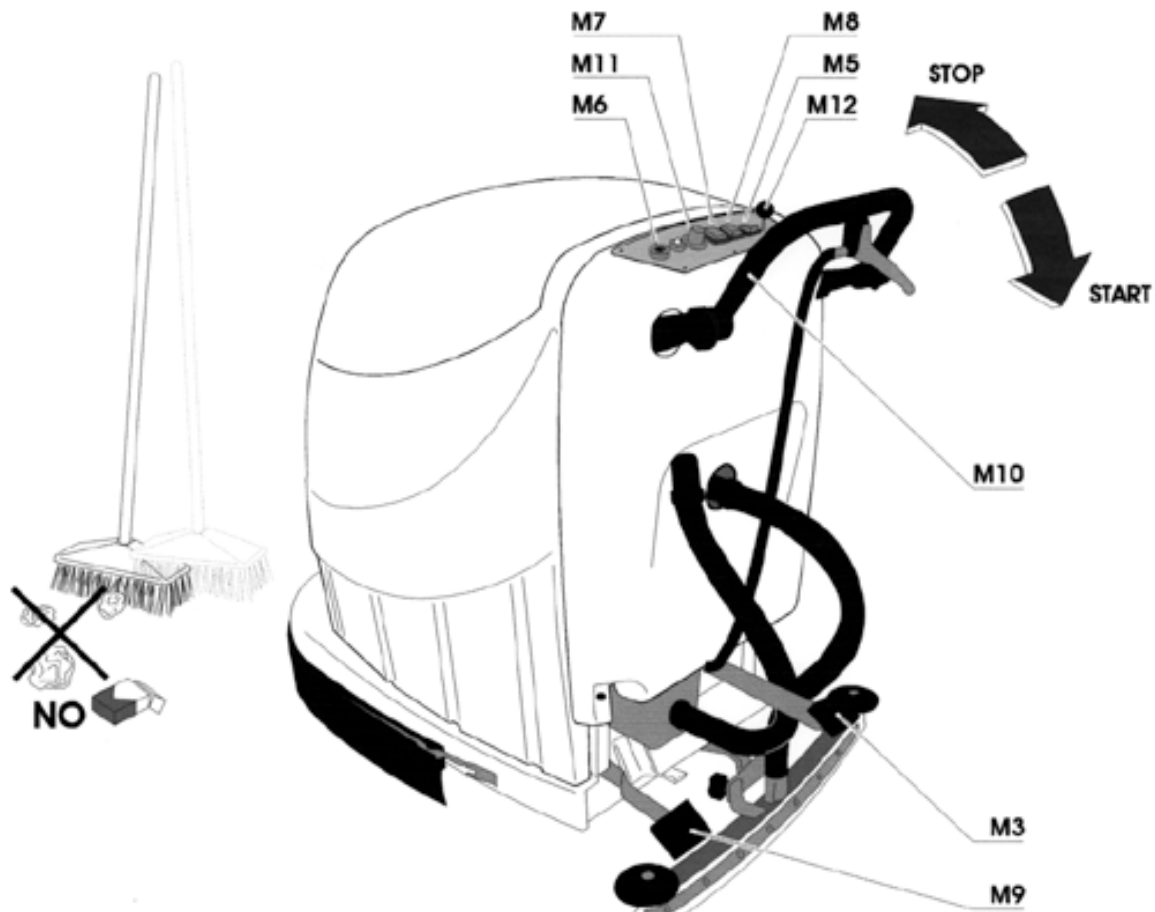

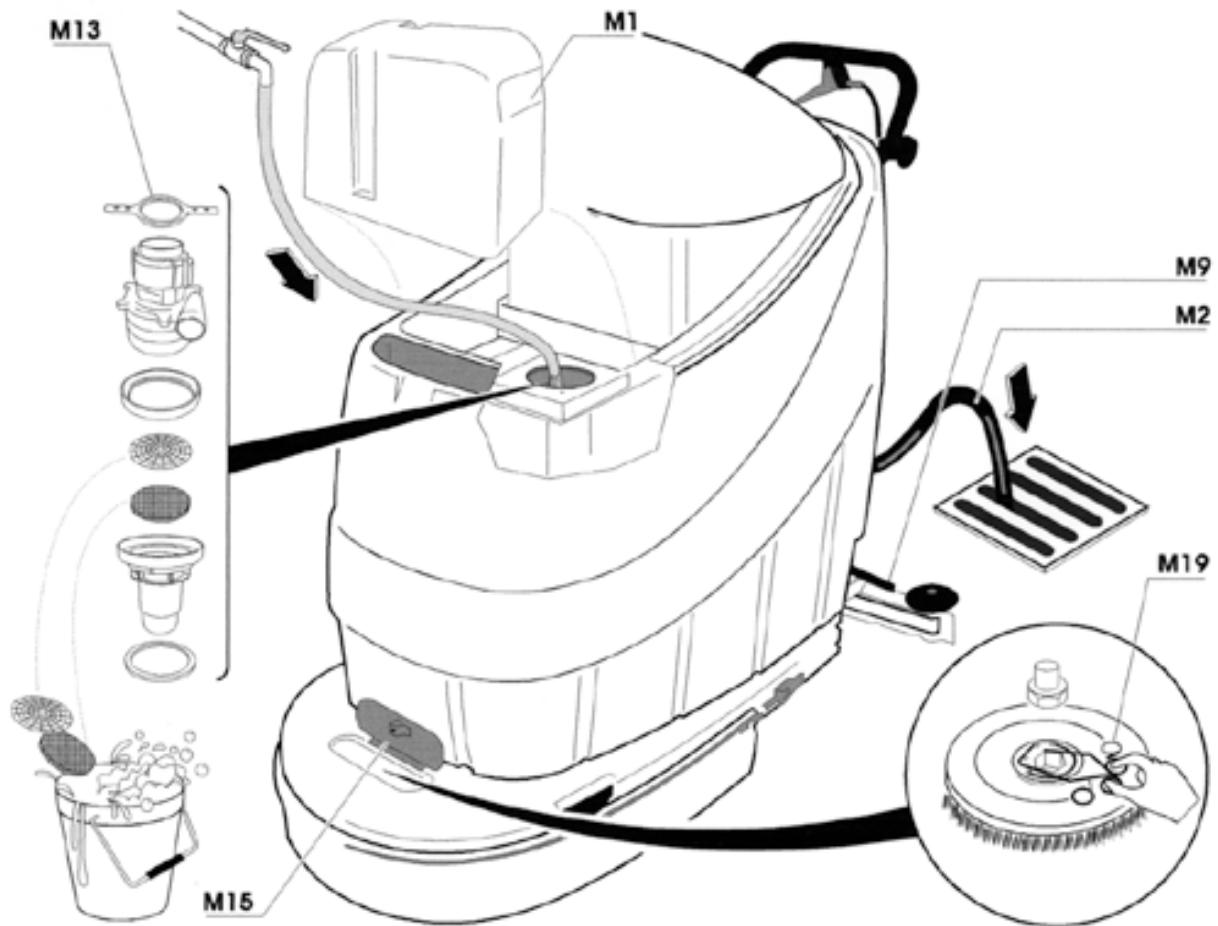

adapt themselves to the inclinations and the drying action improves. Pressing the knob **M14** regulates the pressure of the wipers on the floor. When cleaning shiny or smooth floors and when there are holes (joints between tiles) it is advisable not to use the rear (lowest) rubber wiper.

Installing and recharging the batteries: The batteries are supplied separately and are located in the appropriate compartment underneath the cover; apply a coating of grease (e.g. Vaseline) to the terminals; connect the batteries as shown in the attached diagram; make sure the terminals are securely tightened. The battery charger should be set up in the area where it is planned to leave the machine for recharging. Use the cable supplied to connect to the mains supply, normally 220 V 50 Hz; make sure that the supply voltage is the same as indicated on the battery charger itself. To charge the batteries connect the connector **M5**, which comes directly from the battery compartment, to the battery charger connector; apply voltage using the appropriate button on the charger. The charger will automatically regulate the charging current and will turn itself off when the batteries are recharged.

WARNING: The battery acid may give off harmful fumes. When working near the batteries use protective glasses and clothes.

DO NOT PLACE ANY METAL TOOLS OF ANY KIND ON THE BATTERIES. Recharging the batteries generates explosive gas. Do not smoke, light flames or make sparks. Make sure the charger is switched off before disconnecting. Recharge the batteries in a well-ventilated area and keep the cover open.

WARNING: objects lying on the floor can be thrown at high speed by the brushes, endangering people and/or property.

The area to be cleaned: In order to increase the effectiveness of the detergent, the area to be cleaned should first be swept (manually or by machine) to remove loose dirt that may quickly clog up the suction circuit.

Powering up and operation:

- Turn off the battery charger and disconnect it from the machine;
- Turn the key switch, **M6**, to position 1 and press buttons **M7** and **M8**;
- Lower the brush by pressing pedal **M9**;
- Lower the floor wiper by pressing pedal **M3**;
- Regulate the flow of detergent to a minimum using knob **M12**;
- Press lever **M10**, the machine will go forward, keep pressing the button **M5**, the machine will go backward. Releasing **M10** to stop the machine
- Regulate the forward speed with potentiometer **M11**;
- Finally, use lever **M12** to regulate the dosage of detergent according to the amount of dirt and the speed of the machine, this will come with experience; at this point the floor cleaner will come with experience, at this point the floor cleaner will simultaneously clean and dry the floor:

Particularly dirty floors: Certain floors or environments require particular attention or even a second pass with the cleaner.

In this case you should make one pass with the wiper raised and the brush in the working position; in this way the detergent remains on the floor for longer and will dissolve the tougher dirt. The second pass should be made with the brush and wiper lowered and at a slower speed.

WARNING:

This machine is designed to work in closed industrial environments on level floors or on inclines no steeper than 2%. Do not use inflammable chemicals and/or explosives with this machine.

Floor wiper: Inspect and clean the floor wiper weekly and make sure to restore it to its working condition. If the drying action is not perfect after cleaning the wiper assembly, remove and re-place any worn rubber blades.

Brush: The brush must be kept in working order; to remove a worn brush proceed as follows (follow the procedure in reverse to reassemble):

- Turn off the machine (key switch in OFF position) and lift the brush with the pedal provided (M9);
- Release the catch M15 and remove the rubber spray guard;
- Turn the brush to be re-moved by hand until the coils of spring M19 are accessible;
- By closing together the coils of spring M19 with your fingers (as if you were closing a pair of scissors) the brush will free itself;
- The machine is supplied with a Nylon brush; brushes made of Tynex, broom corn or steel are also available, as well as disc fixtures to which discs can be mounted: Black for thorough cleaning of particularly dirty floors; Green for linoleum floors; Yellow for marble:

Waste Tank: clean the tank every week as follows: lift the cover; remove the motor stop ring M13 and remove the suction motor from its seat; carefully

clean the filter, net and sponge, and remove the dirt which has accumulated in the tank, by water jetting. To ease the operations detach the discharge assembly M2 by unscrewing its side knobs.

Batteries: Check the electrolyte level and top up with distilled water if drops below the level of the battery elements. Keep the batteries clean and dry with anti-static cloths. Recharging must be carried out with the cell plugs removed and the cover of the machine opened so as to allow the gases generated to escape.

In confined spaces these gases can be explosive, so recharging should be done in a well-ventilated area.

NORMS FOR BATTERIES SAFETY. It is necessary to remember that the batteries produce gas that can provoke explosions if they come in contact with flames and sparks. Do not perform repairs on a battery while it's recharging. Don't leave tools or metallic parts on the battery. Always clean up and dry the batteries; the connections must be covered with anti-acid grease or petroleum jelly. Take care that the battery tank is always cleaned.

IN CASE OF ACID LOSS FROM THE BATTERIES: replace the battery with the loss respecting the polarities and the connections shown above. For this operation use rubber gloves, apron and glasses to protect the skin and the eyes.

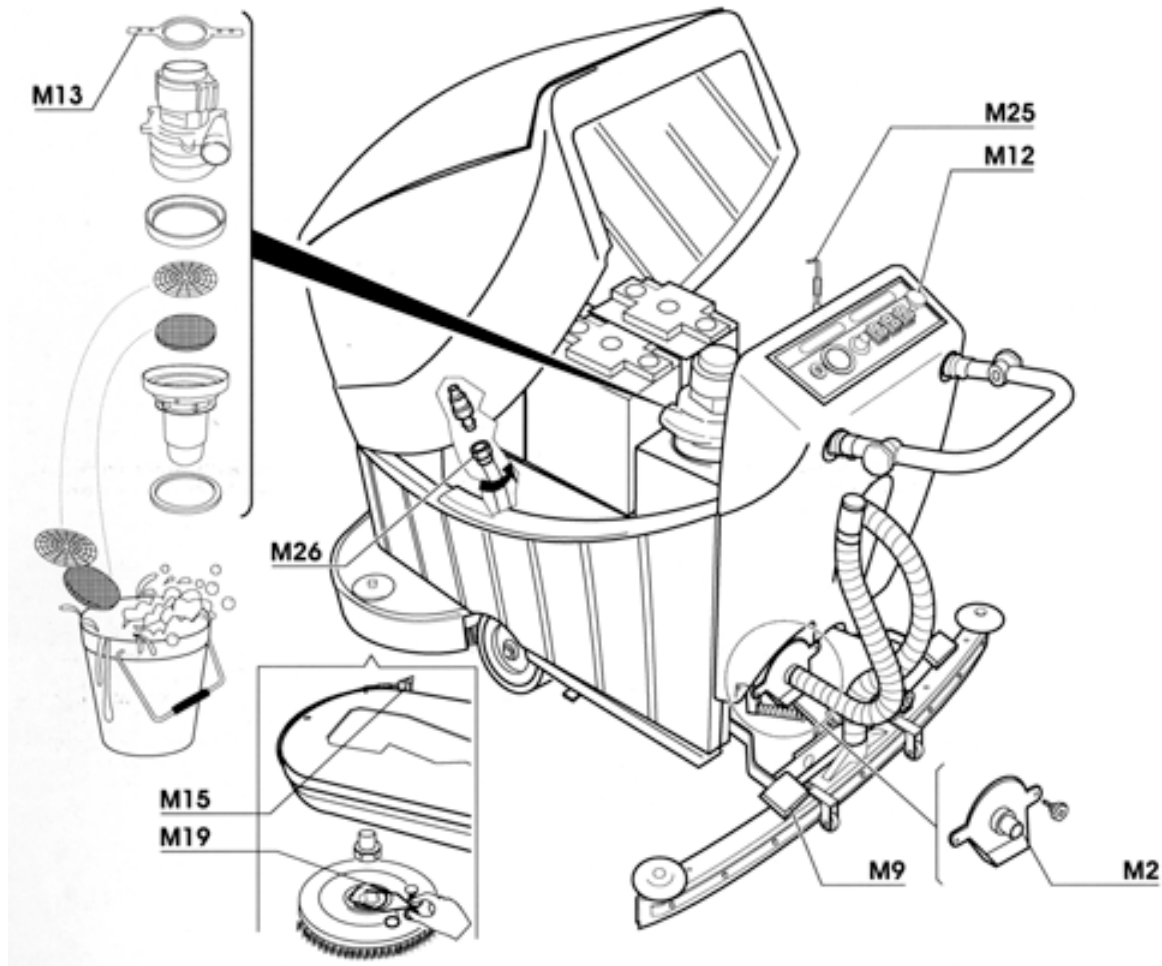

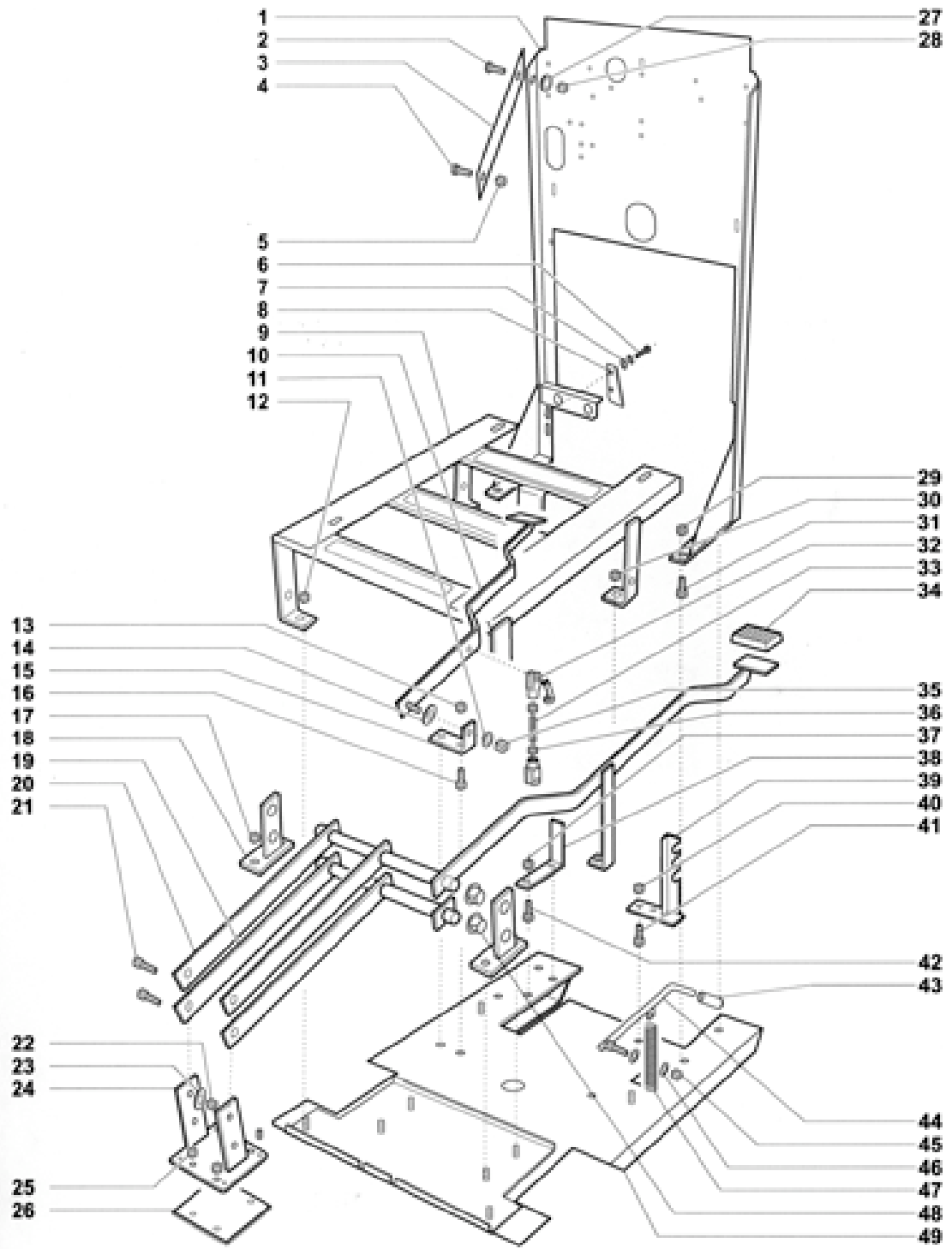

Pos	Part No.	Description
1	701.001	BACK FRAME
2	701.002	SCREW
3	700.003	YOKE
4	701.004	SCREW
5	PAS176	NUT
6	430.065	SCREW
7	430.109	WASHER
8	PAS259	CAM
9	701.009	SUPPORT
10	860.041	PEDAL
11	701.011	WASHER
12	PAS176	NUT
13	PAS176	NUT

Pos	Part No.	Description
14	710.093	WASHER
15	PAS257	BRACKET
16	701.016	SCREW
17	PAS176	NUT
18	PAS227	SUPPORT
19	701.019	LEVER
20	701.020	PEDAL
21	701.021	SCREW
22	850.310	NUT
23	710.093	WASHER
24	701.024	SUPPORT
25	PAS176	NUT
26	700.084	PLATE

Pos	Part No.	Description
27	701.027	WASHER
28	701.028	NUT
29	PAS176	NUT
30	PAS176	NUT
31	701.016	SCREW
32	500.120	FORK
33	860.039	TIE ROD
34	PAS14	PEDAL COVER
35	850.310	NUT
36	PAS176	NUT
37	PAS176	NUT
38	700.017	STOP
39	701.039	BRACKET

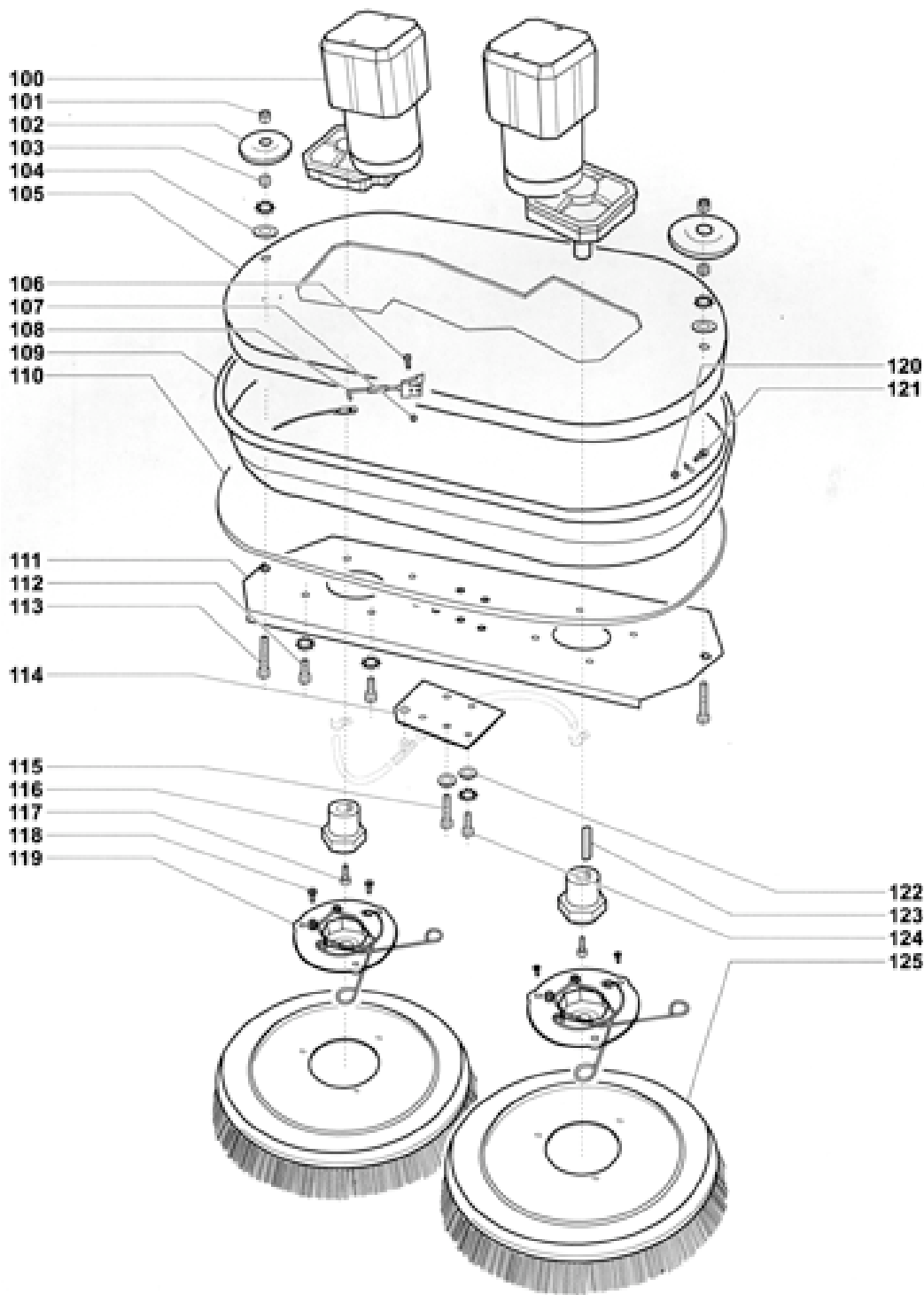

Pos	Part No.	Description
40	PAS176	NUT
41	701.016	SCREW
42	701.016	SCREW
43	701.043	HANDLE
44	701.044	LEVER
45	850.310	NUT
46	701.011	WASHER
47	PAS230	SPRING
48	710.088	BUSHING
49	701.049	FRAME
100	PAS4	MOTOR REDUCER
101	850.317	NUT
102	PAS1	BUFFER WHEEL

Pos	Part No.	Description
103	701.103	NUT
104	701.104	WASHER
105	801.105	PLATE
106	501.024	SCREW
107	701.028	NUT
108	PAS122	HOOK
109	850.305	SPLASH GUARD
110	PAS919	SPLASH GUARD
111	801.111	PLATE
112	430.072	SCREW
113	PAS223	SCREW
114	700.085	PLATE
115	701.115	SCREW

Pos	Part No.	Description
116	PAS5	COUPLING
117	710.135	SCREW
118	701.118	SCREW
119	PAS6A	SUPPORT WITH SPRING
120	500.066	NUT
121	850.306	SCREW
122	PAS188	WASHER
123	430.069.1	TANG
124	710.041	SCREW
125	PAS67	Poly Scrub, 2 brushes, fits PAS28DX
125	PAS68	Nylo Grit 2, brushes, fits PAS28DX"

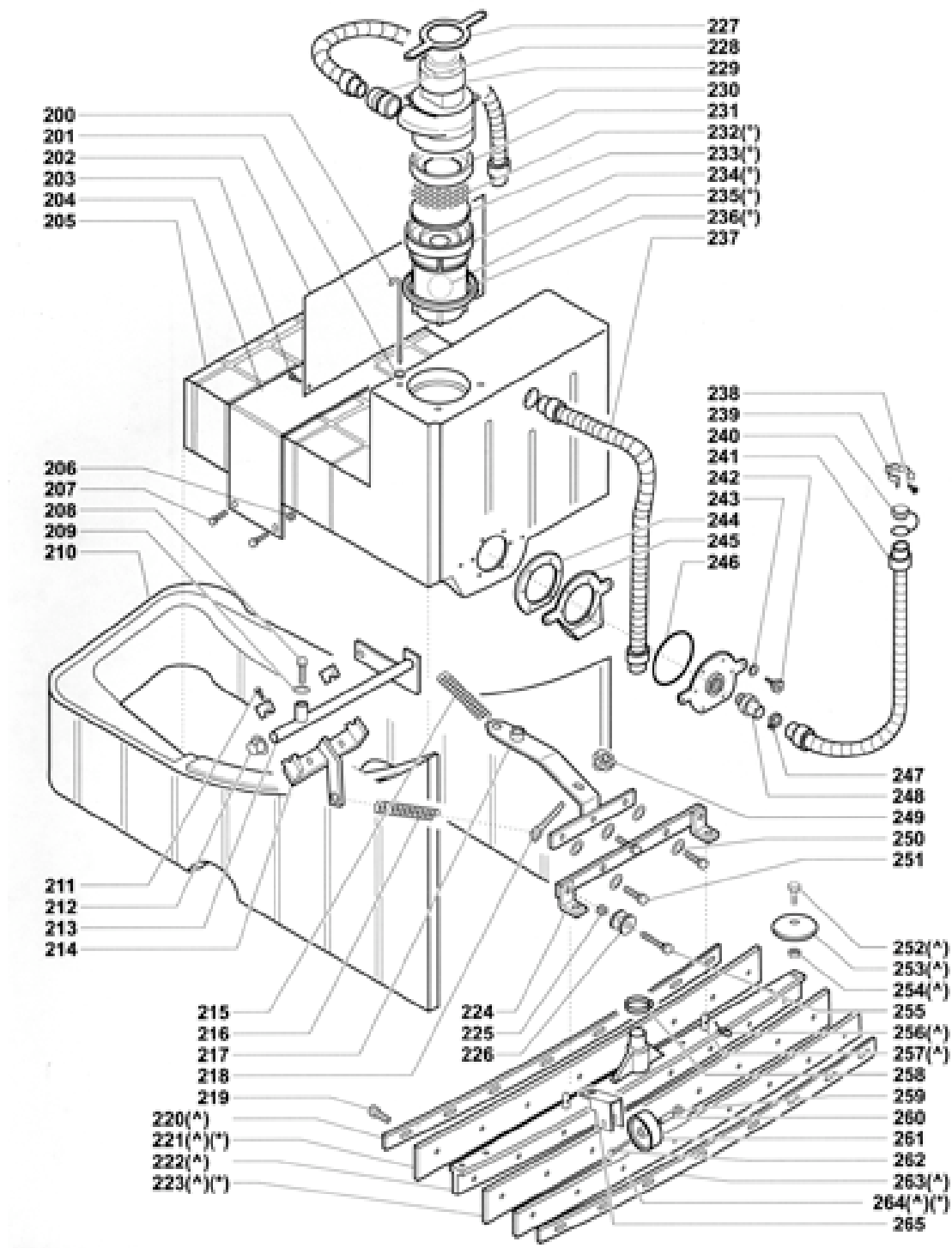

Pos	Part No.	Description
125	PAS130	Strata Grit, 2 brushes, fits PAS28DX
125	PAS94	Scrub Grit II, 2 brushes, fits PAS28DX
125	PAS613	13" Union Mix, 2 brushes, fits PAS28DX
125	PAS69	pad holder, 2 brushes, fits PAS28DX
125	PAS133	Powr-Scuff, 2 brushes, fits PAS28DX
125	PAS962	Poly-Scrub .028 dia. scrub brush nylon, fits PAS32DX
125	PAS963	Nylo-Grit .050 dia. 80 grit HD, fits PAS32DX

Pos	Part No.	Description
125	PAS964	Strata-Grit .060 dia. 46 grit Concrete, fits PAS32DX
125	PAS615	15" Union mix brush, fits PAS32DX
125	PAS961	drive block, fits PAS32DX
125	PAS965	Powr-Scuff .018 dia. 500 grit gen scrub, fits PAS32DX
200	410.105.1	TIE ROD
201	PAS146	WASHER
202	700.101.1	SCREEN
203	430.065	SCREW
204	701.204	REINFORCE
205	700.131	TANK
206	PAS196	NUT

Pos	Part No.	Description
207	701.016	SCREW
208	710.041	SCREW
209	PAS188	WASHER
210	701.210	CHEST
211	710.135	SCREW
212	710.088	BUSHING
213	700.044.1	LEVER
214	700.045.2	SUPPORT
215	PAS230	SPRING
216	PAS31	SPRING
217	700.047.2	LEVER
218	PAS63	TIE ROD PIN
219	PAS223	SCREW
220	650.178	FRONT STRIP

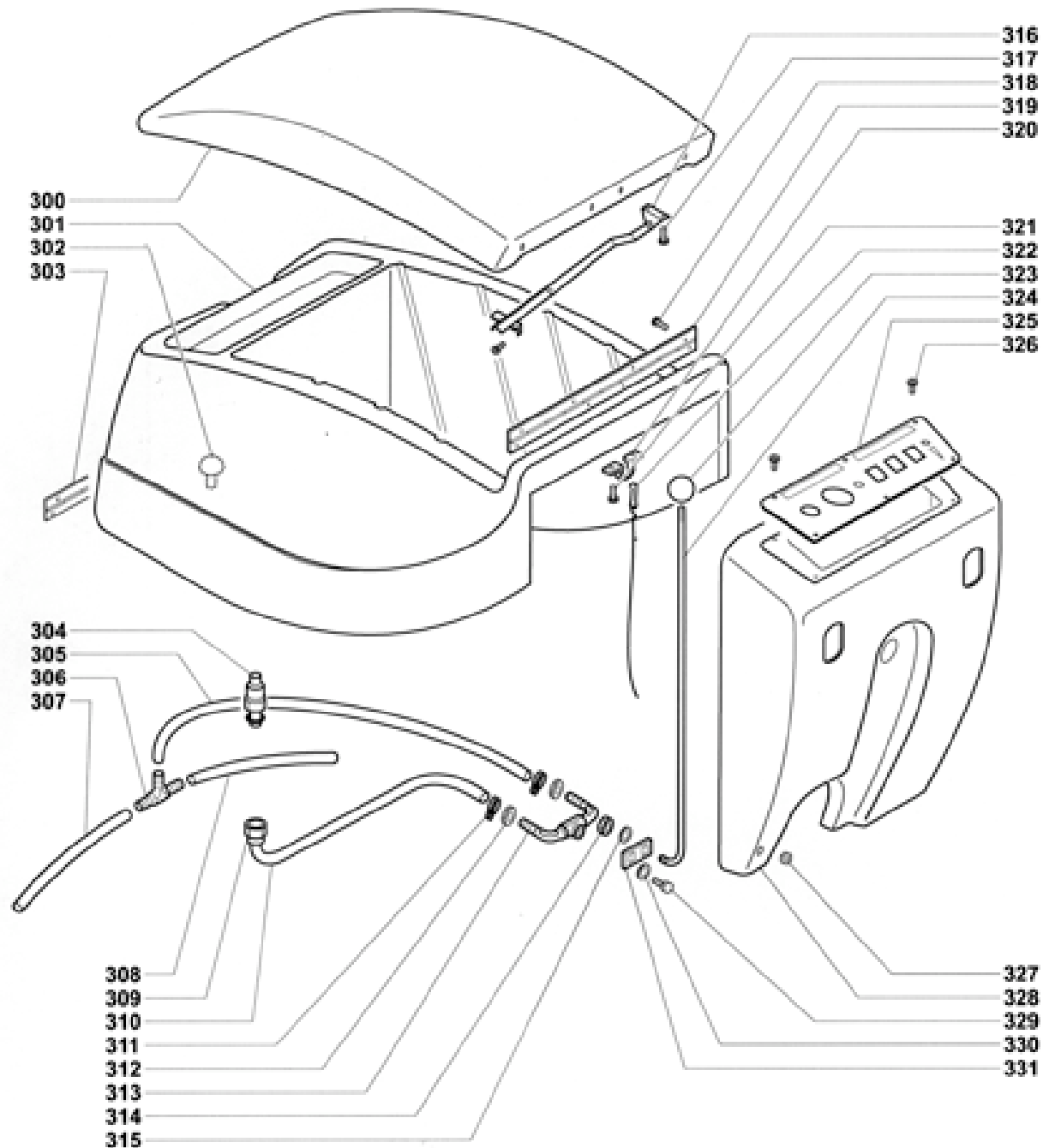

Pos	Part No.	Description
221	PAS145	BLACK RUBBER
222	PAS77	SQUEEGEE BODY
223	PAS143	CREPE RUBBER
224	PAS214	SUPPORT
225	PAS176	NUT
226	500.222.1	REGULATOR
227	PAS15	LOCK RING
228	PAS330	SLEEVE
229	500.257.3	MOTOR
230	PAS37	PIPE
231	PAS102	SEAL
232	PAS79	NET
233	PAS107	SPONGE

Pos	Part No.	Description
234	500.068	SUPPORT
235	500.094	FLOAT LEVEL
236	PAS103	SEAL
237	PAS80	PIPE
238	430.194	SCREW
239	PAS38	PIPE STRAPP
240	PAS36	PLUG
241	PAS37	PIPE
242	PAS74	KNOB
243	PAS136	WASHER
244	PAS70	SEAL
245	PAS440	FIXED FLANGE
246	PAS441	SEAL

Pos	Part No.	Description
247	710.270	HOSE COLLOR
248	PAS393	HOSE FITTING
249	500.223.1	KNOB
250	PAS212	WASHER
251	710.168	SCREW
252	PAS936	SCREW
253	PAS1	BUFFER WHEEL
254	PAS937	NUT
255	710.165	SCREW
256	850.265	PLIT PIN
257	PAS92	PIN
258	PAS191	HOSE COLLOR
259	430.311	NUT

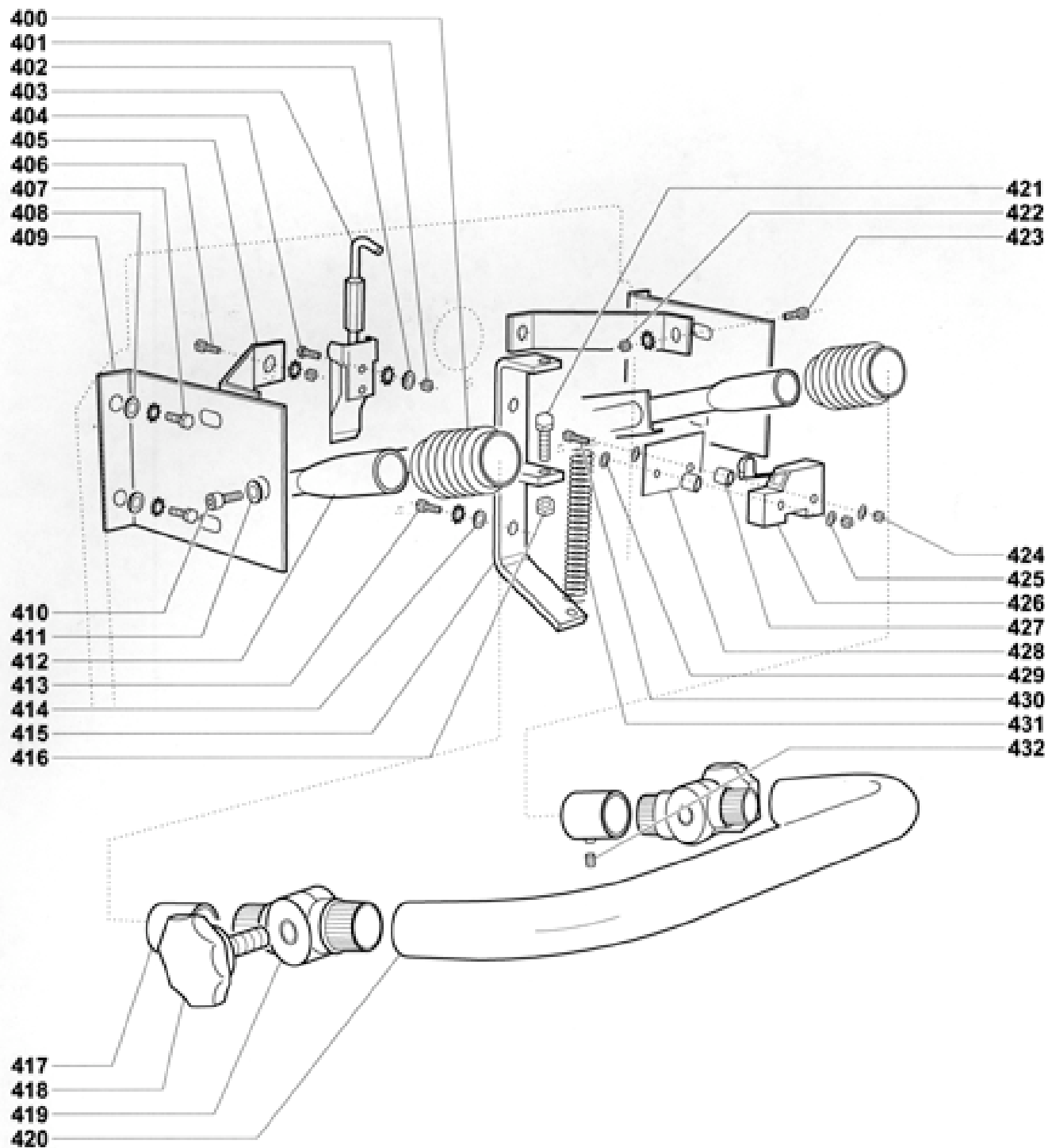

Pos	Part No.	Description
260	PAS382	SPACER
261	PAS379	WHEEL
262	710.176	SCREW
263	PAS261	BACK STRIP
264	PAS144	CREPE RUBBER
265	710.175	SCREW
(°)	PAS17	COMPLETE FLOAT
(*)	PAS76	KIT RUBBER
(^)	PAS78	COMPLETE SQUEEGEE
300	701.300	COVER
301	PAS805	TANK
302	PAS3	FILTER
303	700.138	HINGE

Pos	Part No.	Description
304	PAS83	QUICK CONNECTOR
305	700.143	PIPE
306	850.170	JOINT
307	700.139	PIPE
308	700.141	PIPE
309	PAS83A	QUICK CONNECTOR
310	700.144	PIPE
311	430.091	HOSE COLLOR
312	PAS262	NUT
313	400.160.1	COCK
314	PAS149	NUT
315	PAS146	WASHER
316	PAS84	SUPPORT

Pos	Part No.	Description
317	700.154	SCREW
318	700.155	SCREW
319	PAS110	HINGE
320	700.158	SUPPORT
321	430.056	SCREW
322	700.160	HOOK
323	PAS11	KNOB
324	700.161	ROD
325	700.162.1	PANEL
326	PAS153	SCREW
327	PAS176	NUT
328	701.328	PANEL
329	PAS271	SCREW

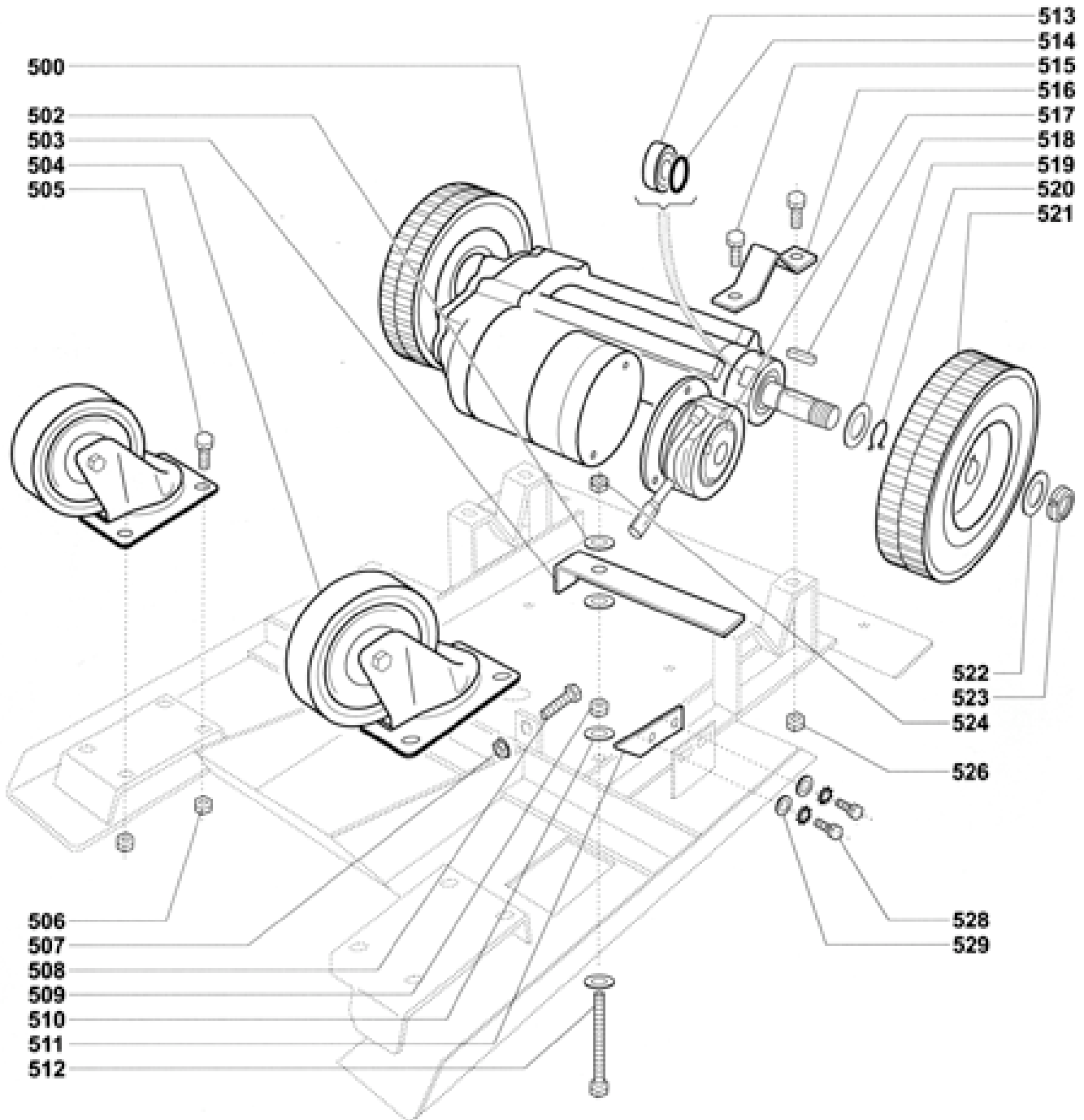

Pos	Part No.	Description
330	PAS270	WASHER
331	PAS269	LEVER
400	PAS335	BELLOW
401	701.028	NUT
402	701.027	WASHER
403	PAS122	HOOK
404	501.047	SCREW
405	701.405	REINFORCE
406	701.406	SCREW
407	500.032	SCREW
408	430.310	WASHER
409	701.409	SQUARE
410	PAS167	SCREW

Pos	Part No.	Description
411	710.040	WASHER
412	700.174	LEVER
413	710.041	SCREW
414	PAS188	WASHER
415	PAS183	SUPPORT
416	PAS176	NUT
417	PAS338	HANDLE
418	PAS337	KNOB
419	PAS339	ARTCULATION
420	430.323.3	HANDLE
421	701.421	SCREW
422	701.422	NUT
423	701.423	SCREW

Pos	Part No.	Description
424	500.066	NUT
425	701.425	WASHER
426	PAS56	MICRO SWITCH
427	700.194	SPACER
428	700.175	RUBBER
429	701.425	WASHER
430	430.194	SCREW
431	PAS172	SPRING
432	PAS148	DOWEL
500	701.500	MOTOR DIFFERENTIAL
502	710.040	WASHER
503	701.503	LEVER
504	500.204.2	SWIVEL WHEEL

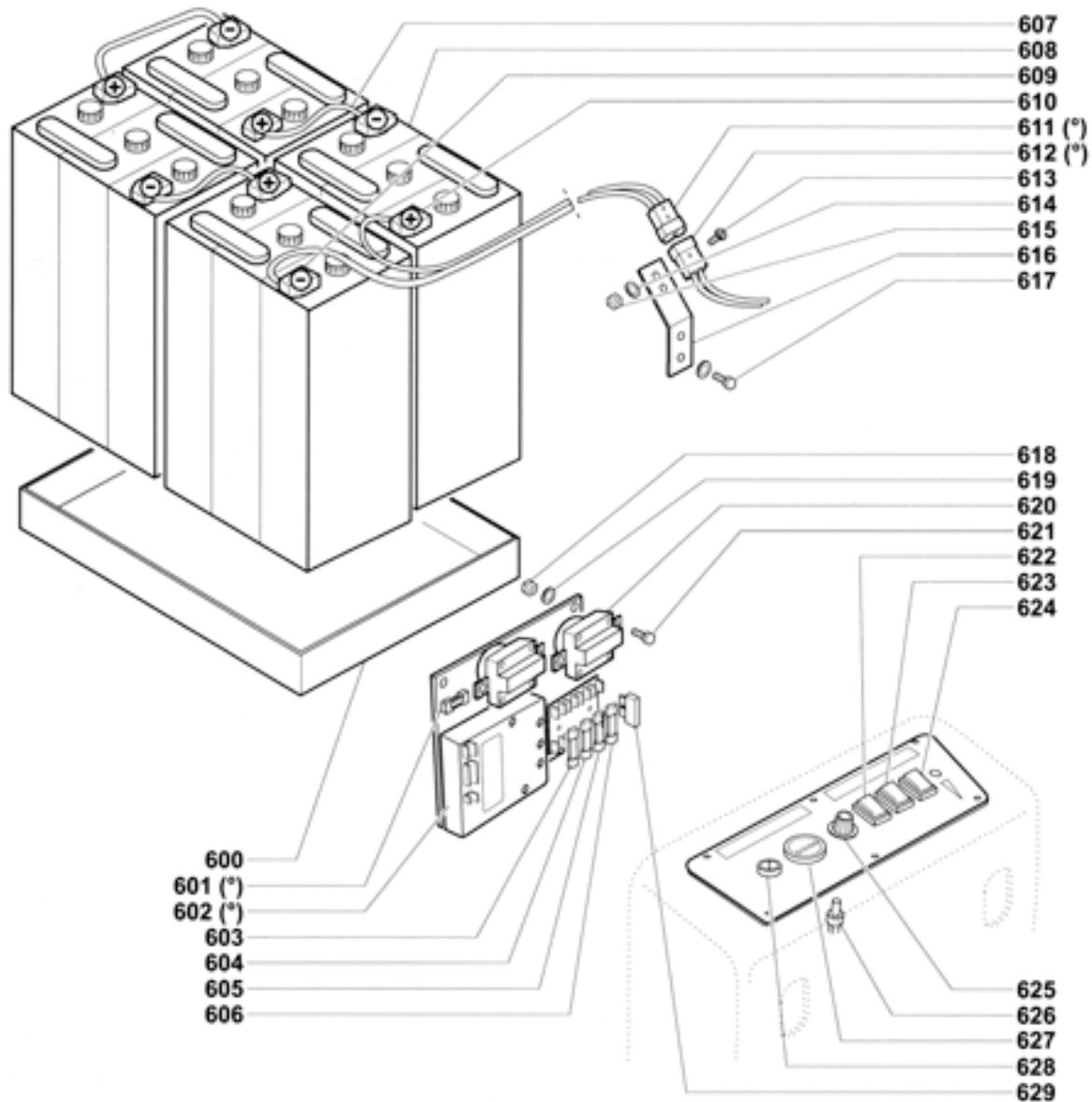

Pos	Part No.	Description
505	701.016	SCREW
506	PAS176	NUT
507	PAS176	NUT
508	701.508	SCREW
509	PAS176	NUT
510	710.040	WASHER
511	PAS259	CAM
512	701.512	SCREW
513	PAS285	BEARING
514	PAS283	SEAL
515	701.115	SCREW
516	510.011	YOKE
517	701.517	ELECTRIC BRAKE
518	PAS351	TANG
519	510.249	RING
520	510.248	SEEGER RING
521	701.521	WHEEL
522	510.246	RING
523	701.523	RING NUT
524	PAS176	NUT

Pos	Part No.	Description
526	PAS176	NUT
528	701.528	SCREW
529	430.310	WASHER
600	PAS86	VAT
601	PAS119	FUSE
602	510.330.1	ELECTRONIC CARD
603	PAS118	FUSE
604	PAS117	FUSE
605	PAS117	FUSE
606	PAS117	FUSE
607	PAS141	CABLE
608	500.250.1	HOSE BATTERY 240 AH
608	500.250.2	ARMATURE BATTERY 240 AH
608	500.250.3	PLATE BATTERY 240 AH
608	700.227	HOSE BATTERY 240 AH
609	500.263	CABLE (-)
610	500.266	CABLE (+)
611	500.258.1	CONNECTION
612	500.258.1	CONNECTION

Pos	Part No.	Description
613	430.299	SCREW
614	430.297	WASHER
615	430.296	NUT
616	650.328	YOKE
617	430.072	SCREW
618	PAS149	NUT
619	430.310	WASHER
620	PAS57	REMOTE CONTROL
621	701.621	NUT
622	510.332.1	REVERSE BUTTON
623	PAS54	SWITCH
624	PAS54	SWITCH
625	PAS88	KNOB
626	PAS55	POTENTIOMETER
627	PAS89	BATTERY INDICATOR
628	PAS53	KEY SWITCH
629	701.629	FUSE HOLDER
(°)	701.630.B	WIRING

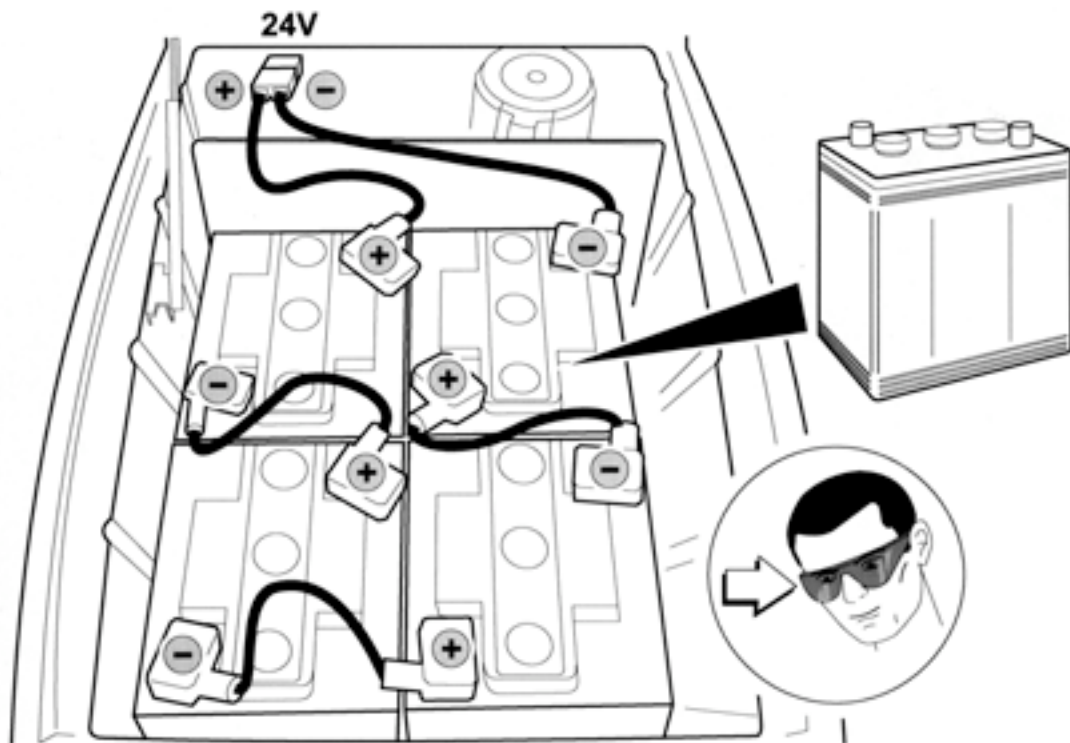
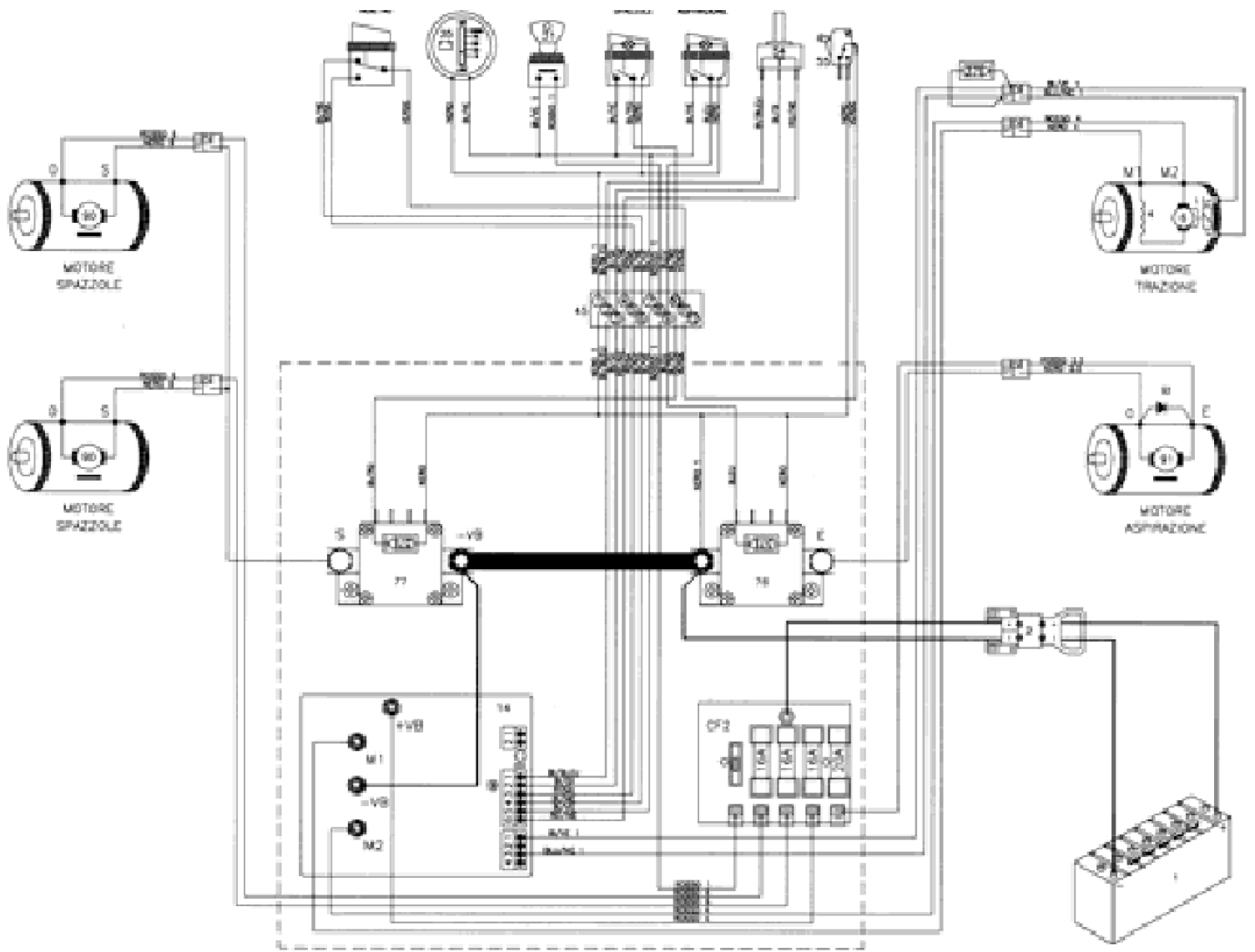

Power-Flite
COMMERCIAL FLOOR CARE EQUIPMENT

A Tacony Company
3101 Wichita Court • Ft. Worth, TX 76140-1755